

Type C Propeller Fans

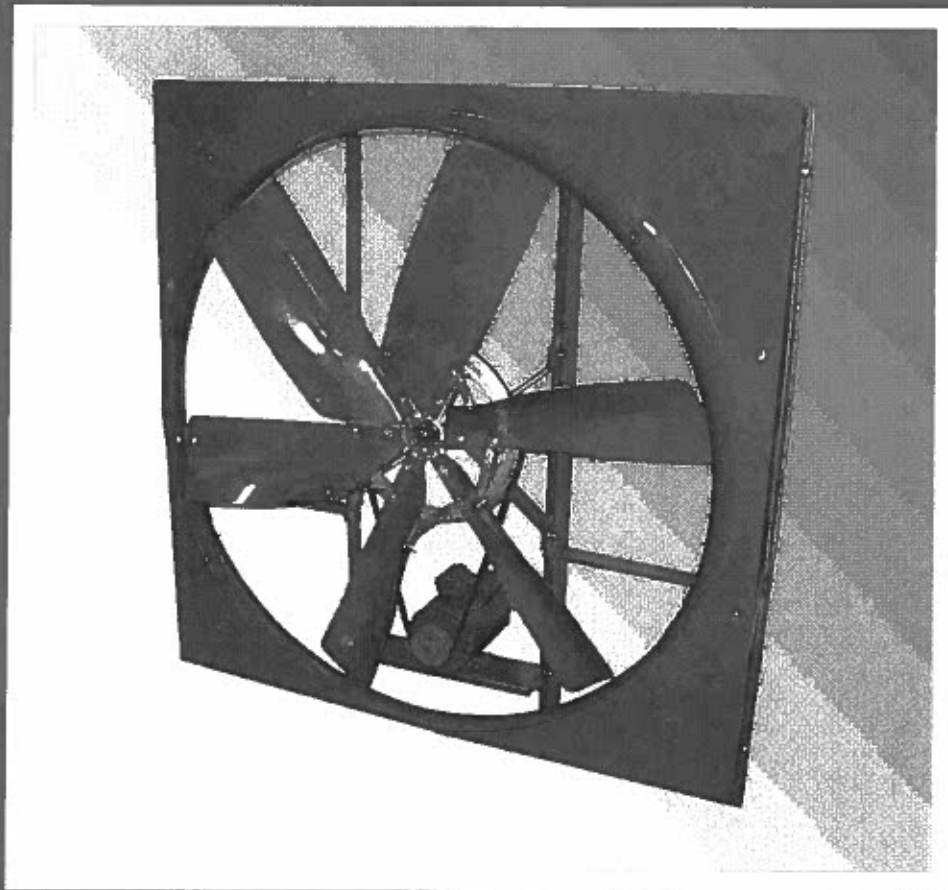

Table of Contents

- Application..... 2
- Type C Fans-General Information..... 2
- Type CB Fans Dimensional Data..... 3
- CBA-CBL-CBH-CBH Performance..... 4
- Type CBC Fans Dimensional Data..... 6
- CBC Performance..... 7
- Type CD Fans Dimensional Data..... 11
- CDP-CDU-CDC Performance..... 12
- Optional Components..... 15
- Accessory Dimensional Data..... Back cover
- Warranty and Caution..... Back cover

Application

Type C wall propeller fans are used for general ventilation and are designed for efficiency and economy. Suggested uses include commercial installations such as warehouses, schools, hospitals, parking garages and industrial uses such as process plants, wastewater treatment plants, and manufacturing facilities.

These propeller fans are rugged and dependable and are available in a wide selection of sizes and performance. These fans can be arranged for supply, exhaust or a combination of both. (See application section for each fan type for proper selection.)

These fans are offered with a wide selection of accessories to complete a well-balanced and specifically engineered air moving system.

Construction

MATERIALS: The fan panel is fabricated of heavy-gauge steel and the uprights which support the motor and propeller are formed from heavy-gauge steel for maximum strength and rigidity. All-aluminum construction is available on all CBA, CBH, CBC, and CDC models. See specific fan model for information on blade material.

Painted parts are coated with a thermosetting epoxy coating to provide a protective coating rated excellent for hardness, impact resistance, adhesion and chemical resistance. For protective coating options see the Accessories section.

METHODS: The entire panel assembly utilizes all-welded construction. It is specifically engineered to provide maximum efficient air movement and quiet operation. All blade assemblies are dynamically balanced.

Parts requiring painting are processed through the American Coolair five-stage pretreatment system prior to the application of any coatings to ensure maximum finish adhesion. These parts use a thermosetting epoxy powder paint with an average thickness of 3 mils and baked at 400°F to a smooth, hard, continuous finish.

Drive Mechanism

BELT DRIVE: Available in sizes from 18 inch to 84 inch, belt driven models are designed for quieter operation and lower initial cost. They use standardly available 1750 RPM motors.

DIRECT DRIVE: Available in sizes from 7 inch to 60 inch, direct driven models require less maintenance, offer longer operating life, increased efficiency and reduced operating cost.

VARIABLE PITCH PULLEYS: Most belt drive models are equipped with a variable pitch motor pulley which allows fan speed adjustment where desirable. The settings made at the factory allow the fan to operate within the maximum safe capabilities of the motor. The pulley may be opened to reduce fan speed and thus decrease air flow.

If an increase in fan speed is desired, contact your American Coolair representative for information on fan performance and motor load before making any adjustment.

Bearings

See specific fan style features for bearing information.

Motors

The American Coolair air-over-motor design provides extra capacity and economy because it serves to dissipate heat and thus increase horsepower capability. Totally enclosed motors are standard. Several alternatives, such as explosion proof motors, energy efficient motors and severe duty motors, are available to fit your specific needs.

Only nationally recognized brand motors with nationwide service facilities are used.

Listings



All Type C ventilators are listed by Underwriters Laboratory, Inc. to U.S. and Canadian safety standards.

UL705 - E39944 Certified ratings licensed by AMCA (Air Movement and Control Association International, Inc.), for both air and sound performance, are available for all Type C fans. These, along with dimensional drawings are included in this form.

Additional Information Available

Octave band sound power levels are available for use by the acoustical engineer in predicting on-the-job sound levels.

American Coolair will provide installation instructions and maintenance information at your request as well as information on any air movement need you may have. For performance requirements not listed or alternate construction requirements contact your American Coolair representative.

American Coolair has over 70 years of experience in air moving systems and offers you the very best equipment and knowledgeable personnel.

Type CB (Models CBA-CBL-CBH-CBHX)

**BELT DRIVE — 2500 to 58,800 CFM
0" to 3/4" STATIC PRESSURE**

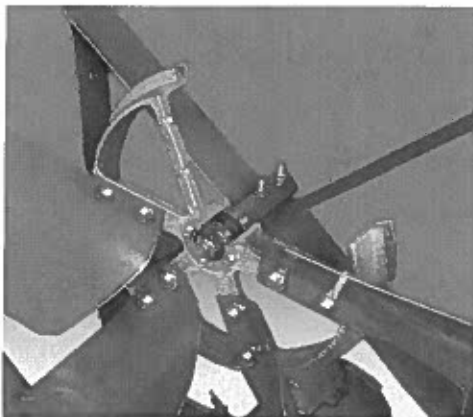
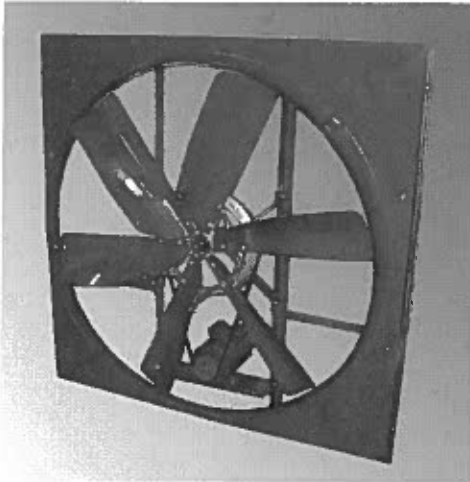

Application

The CBA, CBL, CBH and CBHX fans are known for lower initial cost, proven reliability and quiet, efficient operation at both lower and higher pressures. These fans are generally used for exhaust, but with the addition of a wall housing, they can be turned around for use as a supply fan.

Features

These fans utilize a cross-frame to support American Coolair's unique bearing and shaft assembly. Power is applied directly to the fan/hub assembly in the same plane as the bearings. This reduces bearing load and dramatically increases fan bearing life. Bearings are permanently lubricated and sealed and have an L₁₀ life exceeding 300,000 hours.

The die-formed steel propeller blades are securely attached to the hub to form a strong, rigid propeller assembly.

The motor pulley can be opened to reduce fan speed and decrease air flow on most models. If an increase in fan speed is desired, contact your American Coolair representative for information on fan performance and motor load before making any adjustments.

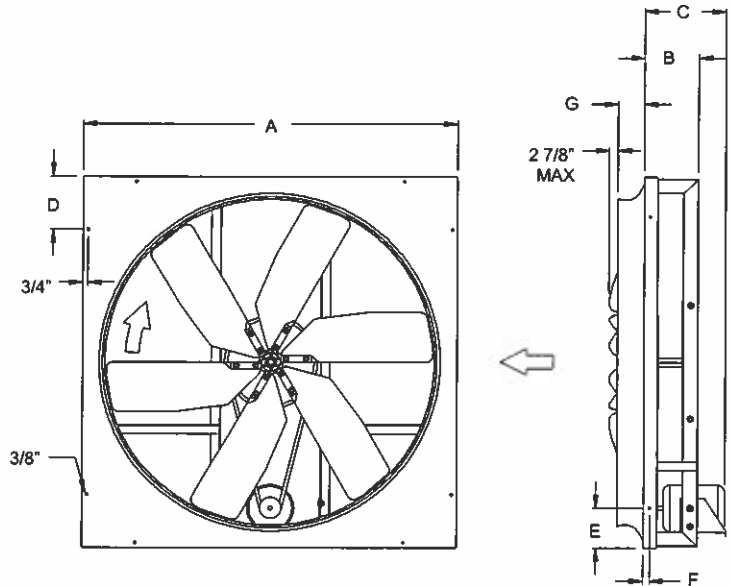

Dimensions

Dimension A is the O.D. of the square fan panel.

Dimension B is the depth from the face of the fan panel to the back of the fan frame.

Dimension C is the maximum with constant speed, 3-phase TEFC motor of maximum horsepower for fan size and style indicated. This dimension will vary with the type and HP of the motor actually selected.

(1) Maximum blade protrusion beyond venturi.

Fan	Dimensions in Inches							Metal Gauges	
	A	B	C	D	E	F	G	Panel	Blade
CBA18	26	5 5/8	14 3/8	3/4	2	1/2	1 1/4	18	14
CBA20	26	5 5/8	14 3/8	3/4	2	1/2	1 1/4	18	14
CBL24	32	5 1/8	12 5/8	6	5	7/8	4	18	14
CBH24			13						
CBL30	38	5 1/8	12 5/8	6	5	7/8	4	18	14
CBH30			14 7/8						
CBL36	44	5 1/8	12 3/4	7	5	7/8	4	16	14
CBH36			17						
CBL42	50	5 1/8	12 3/4	7	4	7/8	4	16	14
CBH42			17						
CBL48	56	5 1/8	12 3/4	8	5	1	4	16	14
CBH48			17						
CBHX48			6 5/8					20 1/4	
CBH54	62	5 1/8	17 1/4	8	6	1	4	16	10
CBHX54			6 5/8					20 1/4	14
CBHX60	68	6 5/8	20 1/4	8	6	1	5	14	14

Performance Ratings

Typical Specifications



American Coolair Corporation certifies that the Type CB fan models shown herein are licensed to bear the AMCA seal. The ratings shown are based on tests and procedures performed in accordance with AMCA Publication 211 and AMCA Publication 311 and comply with the requirements of the AMCA Certified Ratings Program.

Belt driven propeller fans shall be American Coolair Type CBA, CBL, CBH, and CBHX as manufactured by American Coolair Corporation, Jacksonville, Florida; specific models shall be as shown in the fan schedule. Panels and structural angle supports shall be of welded steel construction with recessed orifice to provide additional fan shutter clearance for improved performance. Die formed steel blades shall be firmly attached to cast aluminum hub, which also serves as driven sheave. Fan hub shall rotate on fixed shaft using oversized sealed ball bearings. Belt load shall be applied to hub in the same plane as bearings, eliminating overhung load on bearings and increasing bearing life. Motor pulleys shall be variable pitch. Fans shall be licensed to bear the AMCA Certified Ratings Seal for sound and air performance. (Specify for each fan model in schedule the required CFM and static pressure; motor enclosure, phase and voltage; and accessories such as wall shutter, motor side or front guard, wall housing, etc.)

Item No.	Cubic Feet Per Minute (CFM) at Static Pressure ^{1,7}							Fan Model ²	Fan Size	Motor HP	Fan RPM	Sone Rating ³	Max BHP ^{4,7}	Approx. Ship Wt.	Shutter Model ⁵
	0"	1/8"	1/4"	3/8"	1/2"	5/8"	3/4"								
1	3,190	3,002	2,797	2,536	—	—	—	CBA18H	18	1/3	1475	18.0	0.41	60	SU18-20
2	3,639	3,476	3,302	3,113	2,864	—	—	CBA18J	18	1/2	1683	23	0.61	66	SU18-20
3	4,165	4,023	3,875	3,719	3,549	3,341	—	CBA18K	18	3/4	1926	27	0.91	80	SU18-20
4	4,634	4,507	4,376	4,239	4,096	3,941	3,759	CBA18L	18	1	2143	32	1.25	85	SU18-20
5	3,279	3,002	—	—	—	—	—	CBA20G	20	1/4	1165	13.9	0.31	65	SU18-20
6	3,599	3,348	3,089	—	—	—	—	CBA20H	20	1/3	1279	16.5	0.40	65	SU18-20
7	4,117	3,898	3,676	3,433	—	—	—	CBA20J	20	1/2	1463	21	0.61	71	SU18-20
8	4,700	4,508	4,314	4,118	3,896	—	—	CBA20K	20	3/4	1670	26	0.91	85	SU18-20
9	5,223	5,051	4,877	4,702	4,522	4,317	—	CBA20L*	20	1	1856	30	1.25	90	SU18-20
10	5,792	5,636	5,480	5,323	5,164	5,000	4,817	CBA20M*	20	1 1/2	2058	36	1.70	112	SU18-20
11	5,216	4,460	3,341	—	—	—	—	CBL24G	24	1/4	678	11.8	0.30	70	S24
12	5,909	5,271	4,345	—	—	—	—	CBL24H	24	1/3	768	15.4	0.41	73	S24
13	6,601	6,046	5,327	4,404	—	—	—	CBL24J	24	1/2	858	19.1	0.60	79	S24
14	7,593	7,123	6,567	5,842	5,044	—	—	CBL24K	24	3/4	987	25	0.91	93	S24
15	8,143	7,705	7,248	6,726	5,879	5,119	—	CBH24L*	24	1	1065	28	1.28	98	S24
16	8,992	8,597	8,188	7,755	7,217	6,397	5,719	CBH24M*	24	1 1/2	1176	33	1.72	128	S24
17	7,469	5,985	—	—	—	—	—	CBL30G	30	1/4	509	10.5	0.30	77	S30
18	8,350	7,056	—	—	—	—	—	CBL30H	30	1/3	569	13.1	0.41	80	S30
19	9,304	8,160	6,766	—	—	—	—	CBL30J	30	1/2	634	16.2	0.60	86	S30
20	10,536	9,538	8,431	6,784	—	—	—	CBL30K	30	3/4	718	20	0.91	106	S30
21	11,945	11,072	10,139	9,073	—	—	—	CBH30L	30	1	814	25	1.25	111	S30
22	12,601	11,810	10,932	9,855	8,395	6,779	—	CBH30M	30	1 1/2	865	27	1.70	140	S30
23	13,956	13,247	12,481	11,619	10,528	9,167	7,737	CBH30N	30	2	958	34	2.30	143	S30
24	16,214	15,610	14,971	14,290	13,539	12,648	11,546	CBH30P*	30	3	1113	48	3.36	168	SR30
25	9,059	6,766	—	—	—	—	—	CBL36G	36	1/4	416	6.9	0.30	91	S36
26	10,257	8,453	—	—	—	—	—	CBL36H	36	1/3	471	8.5	0.41	94	S36
27	11,194	9,579	7,020	—	—	—	—	CBL36J	36	1/2	514	9.9	0.60	100	S36
28	13,197	11,847	10,174	—	—	—	—	CBL36K	36	3/4	606	13.4	0.91	114	S36
29	14,373	13,138	11,787	9,624	—	—	—	CBL36L	36	1	660	15.4	1.25	119	S36
30	15,902	14,845	13,330	11,742	—	—	—	CBH36M	36	1 1/2	698	21	1.70	156	S36
31	17,497	16,562	15,313	13,812	12,287	—	—	CBH36N	36	2	768	25	2.30	159	SR36
32	19,706	18,898	17,906	16,618	15,318	13,969	11,777	CBH36P	36	3	865	30	3.44	186	SR36
33	12,557	9,045	—	—	—	—	—	CBL42H	42	1/3	334	8.8	0.41	104	S42
34	14,437	11,407	—	—	—	—	—	CBL42J	42	1/2	384	11.4	0.60	110	S42
35	16,129	13,576	10,304	—	—	—	—	CBL42K	42	3/4	429	14.1	0.91	124	S42
36	18,272	16,245	13,455	—	—	—	—	CBL42L	42	1	486	17.6	1.25	129	S42
37	19,656	17,706	15,431	12,496	—	—	—	CBH42M	42	1 1/2	530	23	1.69	166	S42
38	21,547	19,789	17,804	15,463	12,261	—	—	CBH42N	42	2	581	26	2.30	169	S42
39	24,774	23,266	21,621	19,795	17,699	15,052	—	CBH42P	42	3	668	32	3.43	199	S42

(chart continues next page)

ALL SPECIFICATIONS SUBJECT TO CHANGE WITHOUT NOTICE

Type CB Performance Ratings (cont'd)

Item No.	Cubic Feet Per Minute (CFM) at Static Pressure ^{1,7}							Fan Model ²	Fan Size	Motor HP	Fan RPM	Sone Rating ³	Max BHP ^{4,7}	Approx. Ship Wt.	Shutter Model ⁵
	0"	1/8"	1/4"	3/8"	1/2"	5/8"	3/4"								
40	17,340	13,177	---	---	---	---	---	CBL48J		1/2	318	10.6	0.60	144	S48
41	19,958	16,510	---	---	---	---	---	CBL48K		3/4	366	14.1	0.90	149	S48
42	21,975	18,979	14,938	---	---	---	---	CBL48L	48	1	403	16.9	1.25	154	S48
43	24,163	21,204	18,055	---	---	---	---	CBH48M		1 1/2	432	19.7	1.69	211	S48
44	26,512	23,794	21,127	16,104	---	---	---	CBH48N		2	474	23	2.30	214	S48
45	30,316	27,912	25,634	23,110	17,991	---	---	CBH48P		3	542	29	3.44	259	S48
46	33,778	32,404	30,742	28,706	27,042	25,616	22,790	CBHX48Q		5	660	40	5.74	388	SR48
47	38,129	36,933	35,561	33,911	32,098	30,645	29,434	CBHX48R*		7 1/2	745	49	7.89	445	SR48
48	41,814	40,733	39,530	38,153	36,527	34,915	33,622	CBHX48S*		10	817	57	10.33	479	Note 6
49	18,733	13,770	---	---	---	---	---	CBH54J		1/2	293	11.2	0.60	197	S54
50	21,802	17,875	---	---	---	---	---	CBH54K	54	3/4	341	14.7	0.91	204	S54
51	24,359	21,018	---	---	---	---	---	CBH54L		1	381	17.7	1.24	211	S54
52	26,469	23,491	19,439	---	---	---	---	CBH54M		1 1/2	414	20	1.69	212	S54
53	30,445	27,703	24,139	---	---	---	---	CBX54N		2	415	22	2.30	374	S54
54	34,627	32,284	29,417	25,931	---	---	---	CBHX54P		3	472	26	3.42	374	S54
55	40,129	38,154	35,880	33,210	30,151	25,250	---	CBHX54Q		5	547	33	5.58	402	SR54
56	46,952	45,293	43,469	41,419	39,117	36,592	33,602	CBHX54R		7 1/2	640	43	8.61	459	SR54
57	50,693	49,166	47,513	45,696	43,681	41,467	39,082	CBHX54S*		10	691	50	10.67	491	SR54
58	28,555	23,769	---	---	---	---	---	CBHX60L		1	302	13.0	1.24	348	S60
59	31,864	27,859	---	---	---	---	---	CBHX60M		1 1/2	337	15.8	1.69	360	S60
60	34,512	30,941	25,318	---	---	---	---	CBHX60N		2	365	18.3	2.30	360	S60
61	39,145	36,119	31,981	26,357	---	---	---	CBHX60P	60	3	414	22	3.43	382	S60
62	46,425	43,964	41,005	37,085	32,291	---	---	CBHX60Q		5	491	29	5.68	409	S60
63	53,422	51,324	48,945	46,130	42,560	38,342	---	CBHX60R		7 1/2	565	38	8.58	467	SR60
64	58,812	56,924	54,842	52,485	49,714	46,280	42,430	CBHX60S		10	622	45	11.43	500	SR60

- 1 — Performance certified is for Installation Type A: free inlet, free outlet. Performance ratings do not include the effects of appurtenances (accessories).
- 2 — The first three or four letters of the model number identify fan type, drive configuration and style. The next two numbers indicate fan size, the next letter identifies motor horsepower. Example: Model CBL24K is Type "C", belt drive, Style "L", 24" size, 3/4 H.P.
- 3 — The sound ratings shown are loudness values in hemispherical sones at 1.5m (5 ft.) in a hemispherical free field calculated per AMCA Standard 301. Values shown are for Installation Type A: free inlet hemispherical sone levels. The sound ratings shown are at 0" static pressure.
- 4 — Maximum brake horsepower (BHP) within the catalog performance range. Power rating (BHP) does not include transmission losses. Bearing losses are included. BHP at most static pressures listed is less than that shown, in some cases substantially less. For specific BHP values at individual static pressure points contact your American Coolair representative. Because of the cooling the motor receives from the moving air stream, motor loading beyond the nominal nameplate ratings on these American Coolair fans does not overheat the motor and is within NEMA recommended limits and motor service factor. It is not detrimental to the motor and is economically desirable.
- 5 — Shutter models shown are automatic (gravity) type. Add suffix "M" for manual operation; suffix "E" for motor operation.
- 6 — Consult factory for these shutter specifications.
- 7 — To convert air performance (CFM and SP) and power (BHP) to metric units, multiply CFM x .000472 to obtain cubic meters per second (m³/s). Multiply SP x 248.36 to obtain pascals (Pa). Multiply BHP x .7457 to obtain kilowatts (kW).

Example: 3904 CFM x .000472 = 1.8427 m³/s
0.125 SP x 248.36 = 31.05 Pa
0.886 BHP x .7457 = 0.661 kW

* These models have fixed pitch motor pulleys.

ALL SPECIFICATIONS SUBJECT TO CHANGE WITHOUT NOTICE

Type CBC

BELT DRIVE — 4,400 to 117,900 CFM
0" to 3/4" STATIC PRESSURE

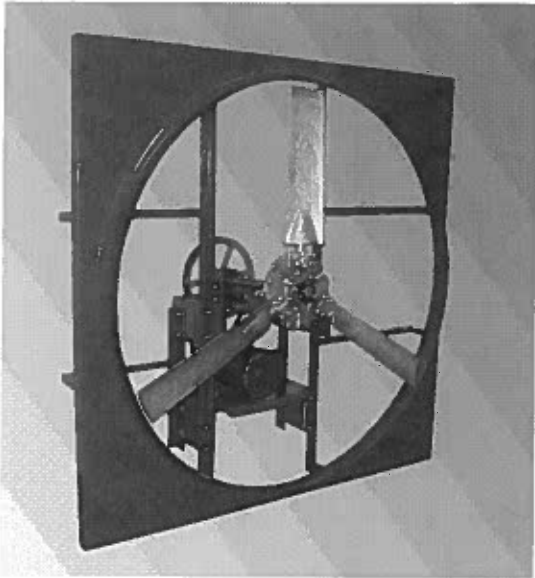

Application

CBC fans are designed to move large volumes of air efficiently at both lower and higher pressures. The 3-bladed units provide efficiency economically, while the 6- and 8-bladed units provide maximum flow at lower speeds for lower sound ratings. These fans are generally used for exhaust, but with the addition of a wall housing, they can be turned around for use as a supply fan.

Features

American Coolair's Type C panel and rugged angle frame form the structure for CBC fans. The steel fan shaft is supported by two pillow-block ball bearings attached to this frame.

Cast aluminum adjustable pitch airfoil blades are securely attached to a heavy cast aluminum hub. Blade pitch is set for catalog performance.

The blade pitch should not be adjusted without first contacting your American Coolair representative.

CBC fans incorporate specifically engineered airfoil sections and hub sizes for optimum efficiency and physical strength.

The motor pulley on most models can be opened to reduce fan speed and thus decrease air flow.

Do not increase fan speed or adjust blade pitch without first contacting your American Coolair representative.

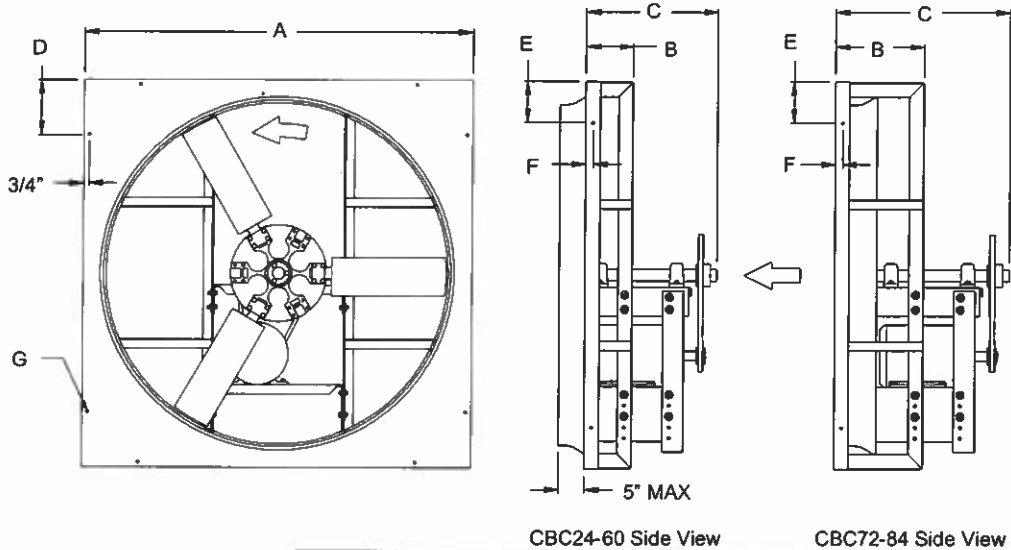

Dimensions

Dimension A is the O.D. of the square fan panel.

Dimension B is the depth from the face of the fan panel to the back of the fan frame.

Dimension C is the maximum width with constant speed, 3-phase TEFC motor of maximum horsepower for fan size and style indicated. This dimension will vary with the type and HP of the motor actually selected.

Dimension G is the diameter of the installation holes.

Drawings of belt, drive and blade assembly are schematic. Multiple belts are used on certain sizes and HPs.

Fan Size	Dimensions in Inches							Panel Gauge
	A	B	C	D	E	F	G	
24	32	5 1/8	18	6	5	7/8	3/8	18
30	38	5 1/8	18	6	5	7/8	3/8	18
36	44	5 1/8	19 1/2	7	5	7/8	3/8	16
42	50	5 1/8	19 1/2	7	4	7/8	3/8	16
48	56	5 1/8	19 1/2	8	5	1	3/8	14
54	62	6 5/8	21	8	6	1	3/8	14
60	68	6 5/8	21	11	9	1	1/2	14
72	80	17 7/8	34	13	11	1 1/8	1/2	10
84	92	17 7/8	34	15	13	1 5/8	1/2	10

Cast aluminum airfoil blades are standard.

Performance Ratings

Typical Specifications



American Coolair Corporation certifies that the Type CBC fan models shown herein are licensed to bear the AMCA seal. The ratings shown are based on tests and procedures performed in accordance with AMCA Publication 211 and AMCA Publication 311 and comply with the requirements of the AMCA Certified Ratings Program.

Belt driven propeller fans shall be American Coolair Type CBC as manufactured by American Coolair Corporation, Jacksonville, Florida; specific models shall be as shown in the fan schedule. Panels and structural angle supports shall be of welded steel construction with recessed orifice to provide additional fan shutter clearance for improved performance. Fan blades shall be airfoil shaped cast aluminum securely attached to heavy cast aluminum hub. Blade pitch shall be adjustable. Ball bearings shall be of heavy duty pillow block type. Motor pulleys shall be variable pitch. Fans shall be licensed to bear the AMCA Certified Ratings Seal for sound and air performance. (Specify for each fan model in schedule the required CFM and static pressure; motor enclosure, phase and voltage; and accessories such as wall shutter, motor side or front guard, wall housing, etc.)

Item No.	Cubic Feet Per Minute (CFM) at Static Pressure ^{1,7}							Fan Model ²	Fan Size	Motor HP	Fan RPM	Sone Rating ³	Max BHP ^{4,7}	Blade No.	Pitch	Approx. Ship Wt.	Shutter Model ⁵
	0"	1/8"	1/4"	3/8"	1/2"	5/8"	3/4"										
1	5,764	4,715	---	---	---	---	---	CBC24G	1/4	897	10.8	0.30	3	25°	119	S24	
2	5,834	4,755	---	---	---	---	---	CBC246G	1/4	659	9.5	0.30	6	35°	128	S24	
3	6,387	5,454	4,394	---	---	---	---	CBC24H	1/3	994	12.8	0.41	3	25°	119	S24	
4	6,471	5,573	4,148	---	---	---	---	CBC246H	1/3	731	11.3	0.41	6	35°	128	S24	
5	7,248	6,438	5,544	4,540	---	---	---	CBC24J	1/2	1128	15.9	0.60	3	25°	125	S24	
6	7,356	6,615	5,419	4,139	---	---	---	CBC246J	1/2	831	14.0	0.60	6	35°	134	S24	
7	8,328	7,631	6,881	6,071	5,177	---	---	CBC24K	3/4	1296	19.7	0.91	3	25°	139	S24	
8	8,436	7,818	6,974	5,803	4,659	---	---	CBC246K	3/4	953	17.5	0.91	6	35°	148	S24	
9	9,253	8,630	7,969	7,267	6,519	5,697	---	CBC24L	24	1	1440	23	1.25	3	25°	144	S24
10	9,366	8,822	8,142	7,174	6,173	---	---	CBC246L	24	1	1058	21	1.25	6	35°	153	S24
11	10,256	9,696	9,110	8,494	7,847	7,165	6,428	CBC24M	1 1/2	1596	27	1.70	3	25°	159	SR24	
12	10,375	9,893	9,323	8,597	7,621	6,765	5,796	CBC246M	1 1/2	1172	24	1.70	6	35°	168	SR24	
13	11,342	10,838	10,315	9,770	9,203	8,613	7,996	CBC24N	2	1765	32	2.30	3	25°	174	SR24	
14	11,482	11,052	10,564	9,985	9,253	8,344	7,575	CBC246N	2	1297	28	2.30	6	35°	183	SR24	
15	12,968	12,529	12,077	11,612	11,133	10,638	10,128	CBC24P	3	2018	40	3.43	3	25°	198	SR24	
16	13,137	12,767	12,361	11,907	11,384	10,756	9,982	CBC246P	3	1484	35	3.43	6	35°	207	SR24	
17	15,384	15,015	14,639	14,256	13,864	13,464	13,054	CBC24Q	5	2394	53	5.70	3	25°	213	Note 6	
18	15,571	15,263	14,934	14,582	14,200	13,779	13,307	CBC246Q	5	1759	47	5.70	6	35°	222	Note 6	
19	8,817	7,159	---	---	---	---	---	CBC30H	1/3	731	12.7	0.41	3	25°	140	S30	
20	8,893	6,922	---	---	---	---	---	CBC306H	1/3	529	10.3	0.41	6	35°	149	S30	
21	9,999	8,591	6,653	---	---	---	---	CBC30J	1/2	829	15.6	0.60	3	25°	146	S30	
22	10,104	8,461	---	---	---	---	---	CBC306J	1/2	601	12.9	0.60	6	35°	155	S30	
23	11,495	10,284	8,799	7,072	---	---	---	CBC30K	3/4	953	19.7	0.91	3	25°	160	S30	
24	11,617	10,242	8,454	---	---	---	---	CBC306K	3/4	691	16.3	0.91	6	35°	169	S30	
25	12,773	11,685	10,510	8,892	7,405	---	---	CBC30L	1	1059	23	1.25	3	25°	165	S30	
26	12,878	11,663	10,187	8,292	---	---	---	CBC306L	1	766	19.4	1.24	6	35°	174	S30	
27	14,149	13,167	12,158	10,877	9,419	8,062	---	CBC30M	30	1 1/2	1173	27	1.70	3	25°	180	S30
28	14,273	13,194	11,946	10,420	8,510	---	---	CBC306M	30	1 1/2	849	23	1.69	6	35°	189	S30
29	15,644	14,757	13,861	12,872	11,557	10,285	9,069	CBC30N	2	1297	32	2.29	3	25°	195	SR30	
30	15,803	14,840	13,763	12,517	11,035	9,200	---	CBC306N	2	940	27	2.30	6	35°	204	SR30	
31	17,900	17,125	16,347	15,550	14,657	13,517	12,342	CBC30P	3	1484	40	3.43	3	25°	219	SR30	
32	18,073	17,240	16,339	15,345	14,223	12,937	11,493	CBC306P	3	1075	33	3.43	6	35°	228	SR30	
33	21,205	20,551	19,896	19,237	18,566	17,850	17,024	CBC30Q	5	1758	53	5.71	3	25°	234	SR30	
34	21,385	20,689	19,954	19,172	18,333	17,422	16,415	CBC306Q	5	1272	44	5.69	6	35°	243	SR30	
35	11,479	9,062	---	---	---	---	---	CBC36J	36	1/2	690	14.9	0.60	3	20°	173	S36
36	11,993	9,758	---	---	---	---	---	CBC366J	36	1/2	498	13.1	0.60	6	30°	182	S36
37	13,209	11,198	8,930	---	---	---	---	CBC36K	36	3/4	794	18.7	0.91	3	20°	187	S36
38	13,702	11,873	---	---	---	---	---	CBC366K	36	3/4	569	16.2	0.91	6	30°	196	S36
39	14,673	12,934	10,838	8,871	---	---	---	CBC36L	36	1	882	22	1.25	3	20°	192	S36
40	15,220	13,622	11,282	---	---	---	---	CBC366L	36	1	632	19.2	1.25	6	30°	201	S36
41	16,237	14,717	12,819	11,015	9,183	---	---	CBC36M	36	1 1/2	976	26	1.69	3	20°	207	S36
42	16,881	15,471	13,695	10,863	---	---	---	CBC366M	36	1 1/2	701	22	1.70	6	30°	216	S36
43	17,951	16,610	14,947	13,247	11,647	9,934	---	CBC36N	36	2	1079	31	2.29	3	20°	222	S36
44	18,639	17,382	15,909	13,816	11,007	---	---	CBC366N	36	2	774	26	2.28	6	30°	231	S36
45	20,529	19,386	18,033	16,504	15,042	13,643	12,224	CBC36P	36	3	1234	39	3.42	3	20°	246	SR36
46	21,312	20,231	19,025	17,605	15,615	13,172	---	CBC366P	36	3	885	32	3.43	6	30°	255	SR36
47	24,356	23,413	22,361	21,162	19,867	18,608	17,405	CBC36Q	36	5	1464	51	5.72	3	20°	261	Note 6
48	25,262	24,362	23,395	22,342	21,151	19,668	17,735	CBC366Q	36	5	1049	42	5.71	6	30°	270	Note 6
49	27,899	27,086	26,206	25,238	24,170	23,039	21,922	CBC36R	36	7 1/2	1677	65	8.59	3	20°	327	Note 6
50	27,935	27,126	26,270	25,356	24,369	23,261	21,923	CBC366R	36	7 1/2	1160	50	7.72	6	30°	384	Note 6

(chart continues next page)

ALL SPECIFICATIONS SUBJECT TO CHANGE WITHOUT NOTICE

Type CBC Performance Ratings (cont'd)

Item No.	Cubic Feet Per Minute (CFM) at Static Pressure ^{1,7}							Fan Model ²	Motor Size	Fan HP	Fan RPM	Sone Rating ³	Max BHP ^{4,7}	Blade No.	Pitch	Approx. Ship Wt.	Shutter Model ⁵
	0"	1/8"	1/4"	3/8"	1/2"	5/8"	3/4"										
99	27,428	19,065	---	---	---	---	---	CBC60L	1	437	25	1.11	3	15°	381	S60	
100	28,128	17,778	---	---	---	---	---	CBC606L	1	304	21	1.16	6	25°	401	S60	
101	31,382	24,760	---	---	---	---	---	CBC60M	1 1/2	500	31	1.66	3	15°	393	S60	
102	31,829	24,731	---	---	---	---	---	CBC606M	1 1/2	344	25	1.68	6	25°	413	S60	
103	34,771	29,285	20,768	---	---	---	---	CBC60N	2	554	37	2.26	3	15°	393	S60	
104	35,253	29,369	---	---	---	---	---	CBC606N	2	381	30	2.28	6	25°	414	S60	
105	39,667	35,018	28,189	21,036	---	---	---	CBC60P	3	632	46	3.35	3	15°	415	S60	
106	39,879	35,008	25,314	---	---	---	---	CBC606P	3	413	38	3.30	6	25°	435	S60	
107	40,792	36,888	29,353	---	---	---	---	CBC608P	3	333	28	3.34	8	35°	485	S60	
108	47,135	43,239	38,812	32,500	26,273	---	---	CBC60Q	60	5	751	63	5.63	3	15°	442	S60
109	47,559	43,691	38,535	28,873	---	---	---	CBC606Q	5	514	52	5.60	6	25°	462	S60	
110	48,632	45,237	42,170	33,641	---	---	---	CBC608Q	5	397	39	5.65	8	35°	512	S60	
111	53,788	50,368	46,894	42,068	36,622	30,983	---	CBC60R	7 1/2	857	81	8.36	3	15°	500	SR60	
112	54,313	50,997	47,035	41,603	---	---	---	CBC606R	7 1/2	587	67	8.34	6	25°	520	SR60	
113	55,492	52,444	49,790	46,804	37,802	---	---	CBC608R	7 1/2	453	49	8.40	8	35°	570	SR60	
114	59,123	56,008	52,907	49,337	44,191	39,475	34,242	CBC60S	10	942	97	11.10	3	15°	533	SR60	
115	59,865	56,883	53,520	49,330	43,084	---	---	CBC606S	10	647	81	11.16	6	25°	553	SR60	
116	61,126	58,317	55,858	53,424	50,051	40,852	---	CBC608S	10	499	59	11.23	8	35°	603	SR60	
117	44,303	35,814	---	---	---	---	---	CBC72N	2	281	24	2.19	8	20°	732	S72	
118	51,083	44,599	35,032	---	---	---	---	CBC72P	3	324	31	3.35	8	20°	754	S72	
119	60,700	55,262	47,784	40,066	---	---	---	CBC72Q	5	385	41	5.62	8	20°	768	S72	
120	69,371	64,532	59,668	51,733	45,056	32,768	---	CBC72R	72	7 1/2	440	52	8.40	8	20°	826	S72
121	76,466	72,029	67,882	61,637	55,122	48,437	38,049	CBC72S	10	485	63	11.24	8	20°	857	SR72	
122	87,187	83,258	79,601	75,745	69,544	63,744	58,787	CBC72T*	15	553	80	16.67	8	20°	928	SR72	
123	96,332	92,758	89,377	86,112	82,174	76,074	70,901	CBC72U*	20	611	98	22.48	8	20°	962	Note 6	
124	54,338	40,521	---	---	---	---	---	CBC84N	2	218	21	2.19	8	20°	1044	S84	
125	62,564	52,069	35,886	---	---	---	---	CBC84P	3	251	26	3.34	8	20°	1067	S84	
126	74,528	66,415	54,355	39,643	---	---	---	CBC84Q	5	299	36	5.65	8	20°	1092	S84	
127	84,997	77,824	68,687	58,350	43,030	---	---	CBC84R	84	7 1/2	341	45	8.38	8	20°	1149	S84
128	93,721	87,139	80,433	69,678	60,413	---	---	CBC84S	10	376	54	11.24	8	20°	1180	SR84	
129	106,931	101,088	95,624	88,192	78,813	71,136	59,347	CBC84T	15	429	69	16.69	8	20°	1253	SR84	
130	117,899	112,565	107,578	102,269	93,763	86,019	79,119	CBC84U*	20	473	83	22.38	8	20°	1287	SR84	

- 1 — Performance certified is for Installation Type A: free inlet, free outlet. Performance ratings do not include the effects of appurtenances (accessories).
- 2 — The first three letters of the model number identify fan type, drive configuration and style. The next two numbers indicate fan size, the next letter identifies motor horsepower. For example: Model CBC48N is Type "C", belt drive, Style "C", 48" size, 2 H.P.
- 3 — The sound ratings shown are loudness values in hemispherical sones at 1.5m (5 ft.) in a hemispherical free field calculated per AMCA Standard 301. Values shown are for Installation Type A: free inlet hemispherical sone levels. The sound ratings shown are at 0" static pressure.
- 4 — Maximum brake horsepower (BHP) within the catalog performance range. Power rating (BHP) does not include transmission losses. Bearing losses are included. BHP at most static pressures listed is less than that shown, in some cases substantially less. For specific BHP values at individual static pressure points contact your American Coolair representative. Because of the cooling the motor receives from the moving air stream, motor loading beyond the nominal nameplate ratings on these American Coolair fans does not overheat the motor and is within NEMA recommended limits and motor service factor. It is not detrimental to the motor and is economically desirable.
- 5 — Shutter models shown are automatic (gravity) type. Add suffix "M" for manual operation; suffix "E" for motor operation.
- 6 — Consult factory for these shutter specifications.
- 7 — To convert air performance (CFM and SP) and power (BHP) to metric units, multiply CFM x .000472 to obtain cubic meters per second (m³/s). Multiply SP x 248.36 to obtain pascals (Pa). Multiply BHP x .7457 to obtain kilowatts (kW).

Example: 3904 CFM x .000472 = 1.8427 m³/s
0.125 SP x 248.36 = 31.05 Pa
0.886 BHP x .7457 = 0.661 kW

ALL SPECIFICATIONS SUBJECT TO CHANGE WITHOUT NOTICE

Type CBC Performance Ratings (cont'd)

Item No.	Cubic Feet Per Minute (CFM) at Static Pressure ^{1,7}							Fan Model ²	Fan Size	Motor HP	Fan RPM	Sone Rating ³	Max BHP ^{4,7}	Blade		Approx. Ship Wt.	Shutter Model ⁵
	0"	1/8"	1/4"	3/8"	1/2"	5/8"	3/4"							No.	Pitch		
51	16,463	13,354	---	---	---	---	---	CBC42K	3/4	631	18.9	0.91	3	20°	232	S42	
52	17,092	14,090	---	---	---	---	---	CBC426K	3/4	453	15.1	0.91	6	30°	241	S42	
53	18,420	15,623	12,748	---	---	---	---	CBC42L	1	706	23	1.25	3	20°	237	S42	
54	18,979	16,349	---	---	---	---	---	CBC426L	1	503	18.0	1.25	6	30°	246	S42	
55	20,246	17,676	15,158	12,111	---	---	---	CBC42M	1 1/2	776	26	1.70	3	20°	252	S42	
56	20,979	18,637	15,683	---	---	---	---	CBC426M	1 1/2	556	21	1.70	6	30°	261	S42	
57	22,542	20,201	18,001	15,589	12,453	---	---	CBC42N	2	864	32	2.29	3	20°	267	S42	
58	23,205	21,111	18,708	15,393	---	---	---	CBC426N	42	2	615	25	2.30	6	30°	276	S42
59	25,673	23,584	21,666	19,672	17,506	14,802	---	CBC42P	3	984	40	3.43	3	20°	291	S42	
60	26,525	24,714	22,752	20,386	17,331	---	---	CBC426P	3	703	31	3.43	6	30°	300	S42	
61	30,396	28,600	26,945	25,331	23,648	21,867	19,938	CBC42Q	5	1165	55	5.71	3	20°	306	SR42	
62	31,393	29,877	28,284	26,573	24,585	22,140	---	CBC426Q	5	832	41	5.69	6	30°	315	SR42	
63	35,066	33,492	32,019	30,613	29,213	27,764	26,251	CBC42R	7 1/2	1344	72	8.57	3	20°	372	Note 6	
64	35,996	34,682	33,318	31,897	30,381	28,660	26,668	CBC426R	7 1/2	954	51	8.58	6	30°	429	Note 6	
65	22,286	18,518	---	---	---	---	---	CBC48L	1	575	23	1.25	3	20°	329	S48	
66	24,611	21,208	16,698	---	---	---	---	CBC48M	1 1/2	635	28	1.68	6	25°	334	S48	
67	27,131	24,062	20,721	15,365	---	---	---	CBC48N	2	700	33	2.26	3	20°	359	S48	
68	26,338	23,218	18,616	---	---	---	---	CBC486N	2	512	28	2.27	6	25°	369	S48	
69	30,968	28,293	25,550	21,826	16,995	---	---	CBC48P	3	799	41	3.39	3	20°	383	S48	
70	30,093	27,457	23,931	19,504	---	---	---	CBC486P	3	585	36	3.39	6	25°	393	S48	
71	28,891	27,036	24,646	22,110	17,286	---	---	CBC488P	3	504	28	3.41	8	30°	433	S48	
72	36,626	34,374	32,071	29,736	26,650	22,702	---	CBC48Q	48	5	945	54	5.61	3	20°	398	SR48
73	35,546	33,360	30,834	27,500	23,794	---	---	CBC486Q	48	5	691	48	5.58	6	25°	408	SR48
74	34,223	32,706	30,914	28,761	26,629	24,161	---	CBC488Q	5	597	37	5.62	8	30°	448	SR48	
75	41,820	39,851	37,852	35,819	33,764	31,175	27,612	CBC48R	7 1/2	1079	69	8.32	3	20°	455	SR48	
76	40,536	38,635	36,582	34,106	31,038	27,808	23,673	CBC486R	7 1/2	788	60	8.28	6	25°	465	SR48	
77	39,152	37,850	36,385	34,681	32,762	30,891	28,997	CBC488R	7 1/2	683	47	8.38	8	30°	505	SR48	
78	46,044	44,258	42,452	40,615	38,768	36,875	34,504	CBC48S	10	1188	83	11.09	3	20°	489	Note 6	
79	44,703	42,986	41,181	39,145	36,698	33,826	30,903	CBC486S	10	869	72	11.11	6	25°	499	Note 6	
80	42,993	41,819	40,530	39,080	37,430	35,664	33,969	CBC488S	10	750	57	11.10	8	30°	539	Note 6	
81	23,897	17,331	---	---	---	---	---	CBC54L	54	1	467	22	1.12	3	20°	367	S54
82	24,545	18,118	---	---	---	---	---	CBC546L	1	354	22	1.16	6	25°	382	S54	
83	27,274	22,248	---	---	---	---	---	CBC54M	1 1/2	533	27	1.66	3	20°	379	S54	
84	27,735	22,627	---	---	---	---	---	CBC546M	1 1/2	400	27	1.67	6	25°	394	S54	
85	30,242	25,651	19,237	---	---	---	---	CBC54N	2	591	32	2.26	3	20°	380	S54	
86	30,716	26,393	19,489	---	---	---	---	CBC546N	2	443	31	2.27	6	25°	395	S54	
87	34,489	30,670	25,683	19,426	---	---	---	CBC54P	3	674	40	3.36	3	20°	402	S54	
88	35,015	31,385	26,047	---	---	---	---	CBC546P	3	505	39	3.37	6	25°	417	S54	
89	34,923	31,816	28,534	24,930	---	---	---	CBC548P	3	424	37	3.37	8	30°	462	S54	
90	40,988	38,123	34,250	29,377	24,447	---	---	CBC54Q	5	801	55	5.64	3	20°	430	S54	
91	41,602	38,628	35,073	30,128	---	---	---	CBC546Q	5	600	53	5.65	6	25°	445	S54	
92	41,512	38,925	36,205	33,442	30,555	22,550	---	CBC548Q	5	504	---	5.65	8	30°	490	S54	
93	46,770	44,345	40,954	37,973	33,060	28,834	22,856	CBC54R	7 1/2	914	70	8.40	3	20°	487	SR54	
94	47,496	44,917	42,085	38,456	34,052	27,310	---	CBC546R	7 1/2	685	68	8.40	6	25°	502	SR54	
95	47,360	45,106	42,762	40,339	37,927	35,450	30,415	CBC548R	7 1/2	575	---	8.41	8	30°	547	SR54	
96	51,427	49,252	46,535	43,341	40,552	35,673	31,882	CBC54S	10	1005	85	11.16	3	20°	519	SR54	
97	52,141	49,803	47,318	44,426	40,599	36,761	30,266	CBC546S	10	752	81	11.11	6	25°	534	SR54	
98	52,054	50,011	47,901	45,720	43,506	41,325	39,066	CBC548S	10	632	---	11.15	8	30°	589	SR54	

(chart continues next page)

ALL SPECIFICATIONS SUBJECT TO CHANGE WITHOUT NOTICE

Type CD (Models CDP-CDU-CDC)

**DIRECT DRIVE — 330 to 61,400 CFM
0" to 3/4" STATIC PRESSURE**

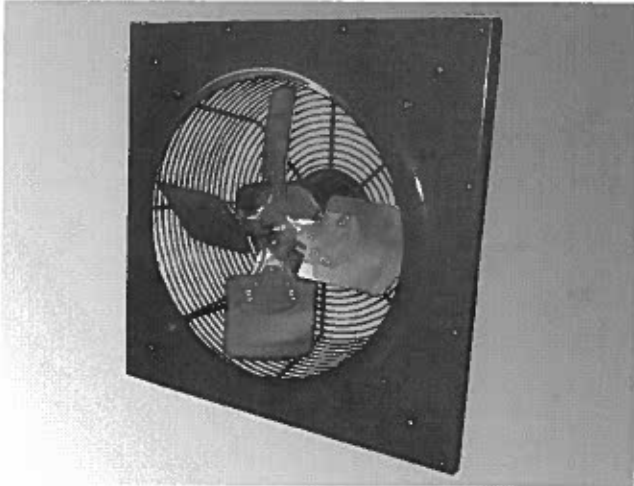

CDP

CDP fans provide an efficient and economical means to move relatively low volumes of air. Each CDP features 3, 4, or 5 aluminum blades. The available speed controller accessory allows the CDP's motor speed to be varied with an to achieve performances from 50% to 100% of catalog ratings. A welded steel wire inlet guard is standard on all CDP models.

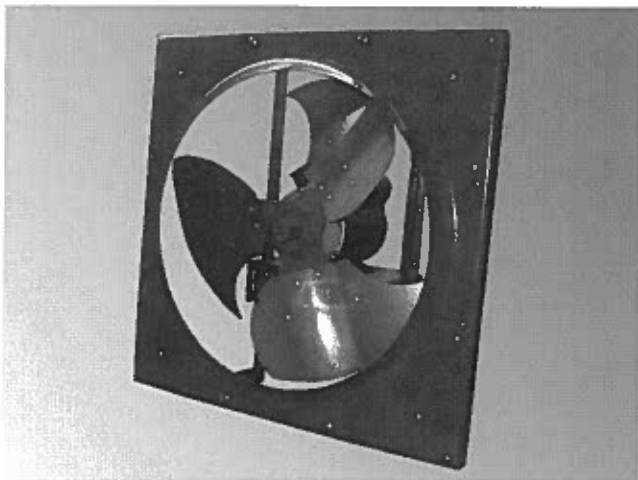

CDU

CDU fans are ideal for quietly moving low to medium volumes of air. The CDU features 3 formed steel "tear-drop" blades specifically engineered for ultra-quiet operation. A PVC coated steel wire inlet guard is standard on all CDU models, and a motor speed controller is available on some models (see the performance table).

Application

CD fans are designed for minimal maintenance requirements and efficient, economical operation.

These fans are suggested for use in situations where the installed fan will be difficult to reach for periodic maintenance.

These fans can be used for either air supply or exhaust by specifying the arrangement desired.

Features

American Coolair's Type C panel and rugged angle frame form the structure for CD fans.

The propeller assembly is connected directly to the motor shaft. There are no bearings or belts to require maintenance. Many motors are permanently lubricated.

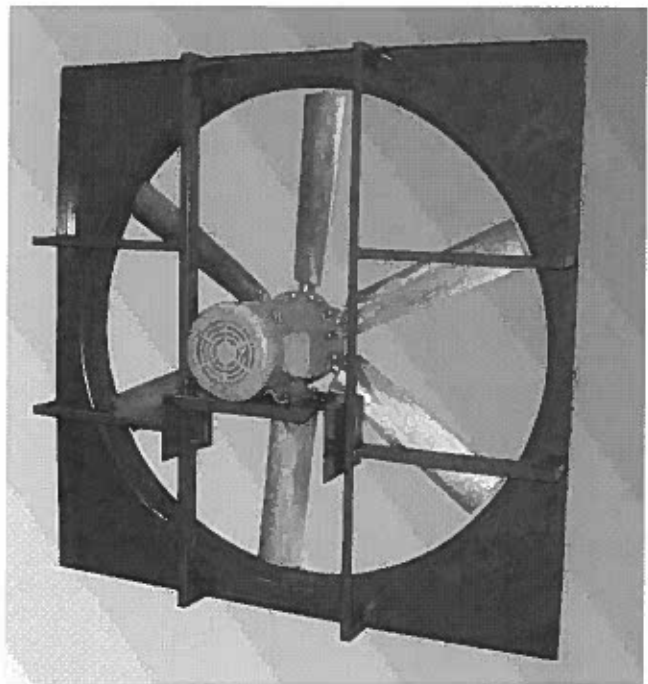

CDC

For moving medium to high air volumes, the CDC is the answer. CDC fans incorporate specifically engineered airfoil sections and hub sizes for optimum efficiency and physical strength. From 3, 4, or 6 cast aluminum adjustable pitch airfoil blades are securely attached to a heavy cast aluminum hub. Blade pitch is set for catalog performance. NOTE: The blade pitch should not be adjusted without first contacting your American Coolair representative.

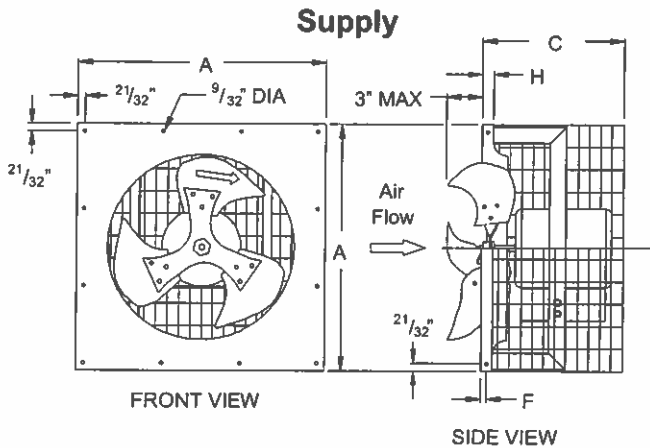
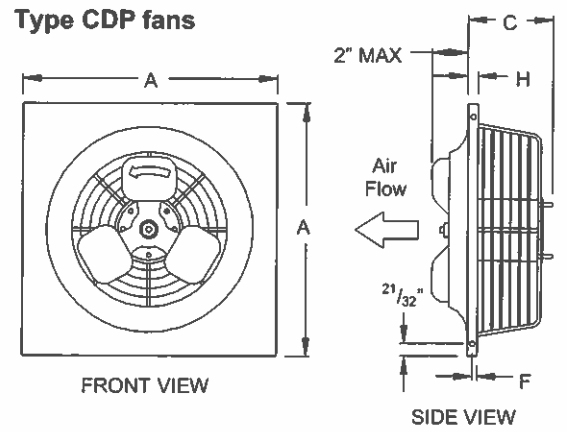
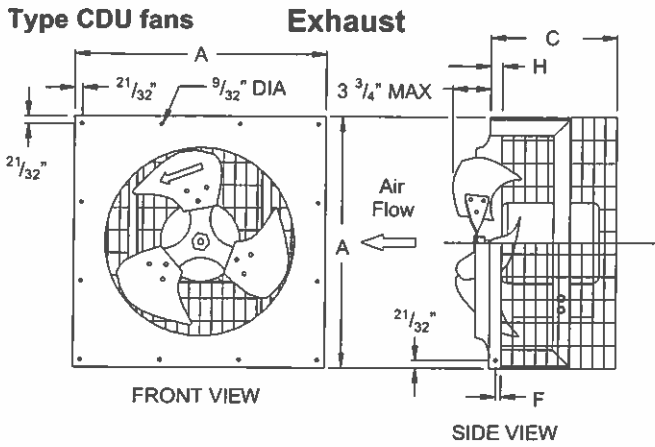

TYPE CDP AND CDU FANS

Fan	Dimensions in Inches			
	A	C	F	H
CDP7	14	5	1/4	1/2
CDP8	14	5	1/4	1/2
CDP10	18	5	1/4	1/2
CDU12	18	11	1/4	1/2
CDP14	22	5	1/2	1
CDU14	22	12	1/2	1
CDP16	22	7 1/2	1/2	1
CDU16	22	12	1/2	1
CDP18	26	7 1/2	1/2	1
CDU18	26	14	1/2	1
CDU20	26	14	1/2	1
CDU24	32	14	1/2	1

Dimensions

Dimension A is the O.D. of the square fan panel.

Dimension B is the depth from the face of the fan panel to the back of the fan frame.

Dimension C is the maximum with constant speed, 3-phase TEFC motor of maximum horsepower for fan size and style indicated. This dimension will vary with the type and HP of the motor actually selected.

Dimension G is the diameter of the installation holes.

TYPE CDC FANS

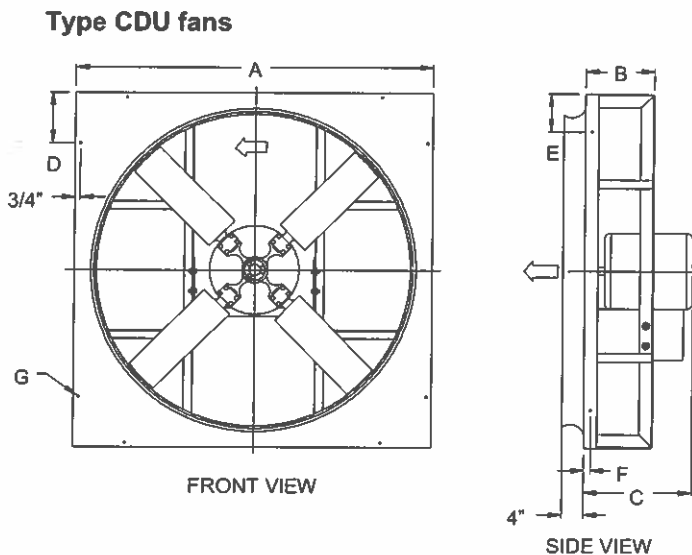

Fan Size	Dimensions in Inches						
	A	B	C	D	E	F	G
18	26	6 3/4	13 3/8	11/16	11/16	9/16	5/16
24	32	5 1/8	12 1/2	6	5	7/8	3/8
30	38	5 1/8	13 7/8	6	5	7/8	3/8
36	44	5 1/8	15 3/8	7	5	7/8	3/8
42	50	5 1/8	15 3/8	7	4	7/8	3/8
48	56	6 5/8	17 3/8	8	5	1	3/8
54	62	6 5/8	17 3/8	8	6	1	3/8
60	68	6 5/8	17 3/8	11	9	1	1/2

Performance Ratings

Typical Specifications



American Coolair Corporation certifies that the Type CD fan models shown herein are licensed to bear the AMCA seal. The ratings shown are based on tests and procedures performed in accordance with AMCA Publication 211 and AMCA Publication 311 and comply with the requirements of the AMCA Certified Ratings Program.

Direct driven propeller fans shall be American Coolair Type CD as manufactured by American Coolair Corporation, Jacksonville, Florida; specific models shall be as shown in the fan schedule. Panels and structural angle supports shall be of welded steel construction. Fan blades shall be formed aluminum (CDP), formed steel (CDU), or cast aluminum (CDC) securely attached to heavy cast aluminum hub. Blade pitch shall be adjustable. Entire blade assembly shall be mounted directly to the motor shaft. Fans shall be licensed to bear the AMCA Certified Ratings Seal for air and sound performance. (Specify for each fan model in schedule the required CFM and static pressure; motor enclosure, phase and voltage; and accessories such as wall shutter, motor side or front guard, wall housing, etc.)

Item No.	Cubic Feet Per Minute (CFM) at Static Pressure ^{1,8}								Fan Model ²	Fan Size	Motor HP	Fan RPM	Sone Rating ³	Max BHP ^{4,8}	Blade No.	Descr. Pitch	Approx. Ship Wt.	Shutter Model ⁵
	0"	1/8"	1/4"	3/8"	1/2"	5/8"	3/4"											
1	333	—	—	—	—	—	—	—	CDP7B17 ⁷	7	1/20	1725	5.1	0.01	5	30°	12	SU7-8
2	530	450	—	—	—	—	—	—	CDP8B17 ⁷	8	1/20	1675	7.1	0.03	5	32°	12	SU7-8
3	793	687	—	—	—	—	—	—	CDP10B15 ⁷	10	1/20	1560	9.2	0.05	5	37°	13	SU10-12
4	1,165	900	—	—	—	—	—	—	CDU12H11 ⁷		1/3	1160	4.4	0.07	3	41°	34	SU10-12
5	1,500	1,380	1,210	—	—	—	—	—	CDU12F17 ⁷	12	1/6	1750	7.6	0.16	3	33°	34	SU10-12
6	1,760	1,630	1,430	—	—	—	—	—	CDU12H17		1/3	1750	9.8	0.23	3	41°	37	SU10-12
7	1,144	1,001	—	—	—	—	—	—	CDP14B15 ⁷		1/20	1450	11.9	0.06	3	18°	22	SU14-16
8	1,750	1,555	—	—	—	—	—	—	CDU14H11 ⁷		1/3	1160	6.7	0.16	3	41°	37	SU14-16
9	2,035	1,920	1,795	—	—	—	—	—	CDU14F17 ⁷	14	1/6	1750	9.2	0.23	3	29°	38	SU14-16
10	2,635	2,520	2,395	2,200	—	—	—	—	CDU14H17		1/3	1750	13.8	0.38	3	41°	40	SU14-16
11	2,388	2,198	—	—	—	—	—	—	CDP16G11 ⁷		1/4	1140	6.7	0.17	4	32°	33	SU14-16
12	2,480	2,235	1,935	—	—	—	—	—	CDU16H11 ⁷	16	1/3	1160	9.7	0.23	3	41°	37	SU14-16
13	2,970	2,845	2,690	2,515	2,285	—	—	—	CDU16H17		1/3	1750	16.6	0.39	3	32°	44	SU14-16
14	3,281	2,842	2,225	—	—	—	—	—	CDP18G10 ⁷		1/4	1060	9.8	0.32	4	40°	38	SU18-20
15	2,905	2,700	2,435	—	—	—	—	—	CDU18H11 ⁷		1/3	1160	8.9	0.30	3	32°	41	SU18-20
16	3,265	3,130	2,960	—	—	—	—	—	CDU18H17		1/3	1750	14.7	0.40	3	21°	44	SU18-20
17	3,760	3,660	3,510	3,355	3,150	—	—	—	CDU18J17		1/2	1750	16.2	0.58	3	25°	50	SU18-20
18	4,385	4,230	4,110	3,960	3,780	—	—	—	CDU18K17		3/4	1750	17.5	0.76	3	32°	57	SU18-20
19	2,890	2,526	2,032	—	—	—	—	—	CDC18F11		1/6	1160	9.5	0.18	4	23.5°	60	SU18-20
20	3,328	3,035	2,632	—	—	—	—	—	CDC18G11	18	1/4	1160	11.5	0.29	6	28°	62	SU18-20
21	3,856	3,543	3,059	—	—	—	—	—	CDC18H11		1/3	1160	12.4	0.38	6	33.5°	58	SU18-20
22	2,642	2,299	1,967	1,595	—	—	—	—	CDC18F17		1/6	1750	15.4	0.19	3	10.5°	51	SU18-20
23	3,659	3,373	3,068	2,706	2,235	—	—	—	CDC18H17		1/3	1750	16.8	0.38	3	19°	55	SU18-20
24	4,050	3,820	3,587	3,320	2,993	2,610	2,194	—	CDC18J17		1/2	1750	18.7	0.57	4	21°	63	SU18-20
25	5,065	4,851	4,569	4,272	3,942	3,456	2,894	—	CDC18K17		3/4	1750	23	0.85	4	29.5°	70	SU18-20
26	5,435	5,214	4,980	4,770	4,546	4,258	3,909	—	CDC18L17		1	1750	22	1.20	6	31°	74	SU18-20
27	3,920	3,680	3,405	3,055	—	—	—	—	CDU20H11 ⁷		1/3	1160	11.5	0.39	3	31°	42	SU18-20
28	3,235	2,870	—	—	—	—	—	—	CDU20H17	20	1/3	1750	22	0.39	3	13°	45	SU18-20
29	4,940	4,815	4,670	4,520	4,340	—	—	—	CDU20K17		3/4	1750	24	0.89	3	24°	58	SU18-20
30	4,670	4,175	3,180	—	—	—	—	—	CDU24G8		1/4	830	8.9	0.28	3	28°	63	SU24
31	4,800	4,345	—	—	—	—	—	—	CDU24H11 ⁷		1/3	1160	14.1	0.39	3	20°	53	SU24
32	6,525	6,220	5,815	—	—	—	—	—	CDU24J11 ⁷		1/2	1160	16.2	0.69	3	28°	63	SU24
33	5,890	4,869	3,546	—	—	—	—	—	CDC24G8		1/4	870	12.1	0.29	3	28°	95	S24
34	6,923	6,304	5,478	3,998	—	—	—	—	CDC24J8		1/2	870	15.4	0.57	6	30.5°	119	S24
35	5,659	4,996	4,300	3,262	—	—	—	—	CDC24H11		1/3	1160	17.7	0.37	3	15.5°	100	S24
36	7,197	6,519	5,714	4,812	—	—	—	—	CDC24J11	24	1/2	1160	19.1	0.59	3	23.5°	95	S24
37	8,567	7,747	6,728	5,837	4,308	—	—	—	CDC24K11		3/4	1160	22	0.85	3	33°	104	S24
38	9,318	8,574	7,813	6,957	5,707	—	—	—	CDC24L11		1	1160	25	1.14	4	33.5°	122	S24
39	8,229	7,753	7,358	6,983	6,460	5,854	5,210	—	CDC24L17		1	1750	34	1.18	3	14.5°	100	S24
40	9,810	9,382	8,942	8,470	7,916	7,374	6,807	—	CDC24M17		1 1/2	1750	36	1.70	3	19.5°	122	SR24
41	11,646	11,235	10,739	10,221	9,651	9,052	8,445	—	CDC24N17		2	1750	39	2.31	3	27°	117	SR24
42	13,449	12,948	12,461	12,005	11,563	11,089	10,517	—	CDC24P17		3	1750	56	3.47	4	31°	143	SR24

(chart continues next page)

ALL SPECIFICATIONS SUBJECT TO CHANGE WITHOUT NOTICE

Type CDC Performance Ratings (cont'd)

Item No.	Cubic Feet Per Minute (CFM) at Static Pressure ^{1,8}							Fan Model ²	Fan Size	Motor HP	Fan RPM	Sone Rating ³	Max BHP ^{4,8}	Blade No.	Descr. Pitch	Approx. Ship Wt.	Shutter Model ⁵
	0"	1/8"	1/4"	3/8"	1/2"	5/8"	3/4"										
43	6,959	5,680	3,716	—	—	—	—	CDC30G8	1/4	870	15.3	0.29	3	12.5°	108	S30	
44	9,727	8,287	6,678	—	—	—	—	CDC30J8	1/2	870	16.5	0.58	3	22.5°	116	S30	
45	11,088	9,857	8,475	6,852	—	—	—	CDC30K8	3/4	870	21	0.85	4	25°	121	S30	
46	10,211	9,439	8,380	7,253	5,364	—	—	CDC30K11	3/4	1160	26	0.87	3	15°	131	S30	
47	11,971	11,026	9,884	8,785	7,265	—	—	CDC30L11	30	1	1160	27	1.14	3	19.5°	136	S30
48	13,453	12,657	11,661	10,742	9,675	8,208	—	CDC30M11	1 1/2	1160	31	1.70	4	22°	162	S30	
49	15,421	14,507	13,519	12,375	11,277	10,049	—	CDC30N11	2	1160	34	2.27	4	27°	175	SR30	
50	13,716	13,156	12,517	11,835	11,161	10,457	9,695	CDC30N17	2	1750	47	2.24	3	12°	131	S30	
51	16,883	16,339	15,746	14,907	14,287	13,592	12,818	CDC30P17	3	1750	52	3.46	3	17.5°	157	SR30	
52	20,296	19,791	19,262	18,500	17,905	17,332	16,731	CDC30Q17	5	1750	65	5.73	4	22°	175	SR30	
53	15,166	13,428	11,504	8,275	—	—	—	CDC36L6	1	680	24	1.13	6	23.5°	195	S36	
54	17,616	16,111	13,671	10,232	—	—	—	CDC36M6	1 1/2	680	26	1.67	6	30°	247	S36	
55	9,928	8,214	6,126	—	—	—	—	CDC36J8	1/2	870	24	0.56	3	8.5°	139	S36	
56	13,266	11,226	9,218	—	—	—	—	CDC36K8	3/4	870	26	0.85	3	15.5°	150	S36	
57	15,110	13,215	10,748	8,133	—	—	—	CDC36L8	1	870	27	1.14	3	20°	178	S36	
58	17,697	15,810	13,253	10,129	—	—	—	CDC36M8	1 1/2	870	28	1.72	3	27.5°	185	S36	
59	19,152	17,634	15,906	13,468	—	—	—	CDC36N8	2	870	33	2.30	4	28.5°	239	SR36	
60	22,314	21,202	19,777	17,836	15,385	12,578	—	CDC36P8	36	3	870	39	3.41	6	29.5°	270	SR36
61	15,810	14,417	12,949	11,604	10,038	—	—	CDC36M11	1 1/2	1160	40	1.70	3	12.5°	185	S36	
62	18,781	17,324	15,688	13,922	12,336	10,551	—	CDC36N11	2	1160	42	2.31	3	17.5°	194	SR36	
63	22,145	20,931	19,114	17,409	15,401	13,202	—	CDC36P11	3	1160	44	3.44	3	24°	240	SR36	
64	25,938	24,835	23,680	22,432	20,951	19,063	16,909	CDC36Q11	5	1160	54	5.71	4	29.5°	289	Note 6	
65	22,279	21,361	20,488	19,630	18,799	17,981	17,159	CDC36Q17	5	1750	79	5.73	3	11°	196	SR36	
66	27,585	26,651	25,669	24,602	23,646	22,722	21,819	CDC36R17	7 1/2	1750	83	8.47	3	16.5°	240	Note 6	
67	31,604	30,726	29,804	28,832	27,791	26,684	25,542	CDC36S17	10	1750	78	11.19	3	20.5°	267	Note 6	
68	18,329	15,148	11,428	—	—	—	—	CDC42L6	1	680	28	1.16	3	18.5°	237	S42	
69	20,660	17,624	14,584	11,783	—	—	—	CDC42M6	1 1/2	680	31	1.71	4	21.5°	293	S42	
70	22,048	19,876	17,980	16,050	—	—	—	CDC42N6	2	680	36	2.31	6	22°	319	S42	
71	16,053	13,871	11,574	8,770	—	—	—	CDC42L8	1	870	33	1.14	3	8°	229	S42	
72	19,684	17,398	14,856	12,241	—	—	—	CDC42M8	1 1/2	870	37	1.70	3	13°	238	S42	
73	22,803	20,405	17,788	14,905	—	—	—	CDC42N8	2	870	41	2.27	3	17.5°	286	S42	
74	23,247	21,939	20,679	19,429	18,052	16,304	13,495	CDC42P8	42	3	870	49	3.31	6	15°	351	S42
75	19,570	17,975	16,339	14,624	12,881	10,654	—	CDC42N11	2	1160	51	2.29	3	6°	189	S42	
76	23,738	21,937	20,306	18,759	17,055	14,854	12,235	CDC42P11	3	1160	58	3.31	3	10.5°	225	S42	
77	31,267	29,640	27,673	25,656	23,586	21,408	19,055	CDC42Q11	5	1160	70	5.78	3	18.5°	240	SR42	
78	30,907	29,798	28,711	27,672	26,655	25,554	24,398	CDC42R17	7 1/2	1750	114	8.45	3	7°	225	SR42	
79	35,812	34,607	33,414	32,280	31,206	30,175	29,155	CDC42S17	10	1750	128	11.27	3	10.5°	245	Note 6	
80	19,158	15,792	12,004	—	—	—	—	CDC48L6	1	680	29	1.16	3	9°	270	S48	
81	23,063	19,348	15,364	—	—	—	—	CDC48M6	1 1/2	680	31	1.70	3	14°	308	S48	
82	24,888	21,994	18,685	15,530	—	—	—	CDC48N6	2	680	37	2.33	4	15.5°	331	S48	
83	23,584	21,044	18,143	15,270	11,815	—	—	CDC48N8	2	870	41	2.26	3	8°	302	S48	
84	28,999	26,364	23,143	20,083	16,624	—	—	CDC48P8	3	870	47	3.45	3	13.5°	319	S48	
85	35,919	32,759	29,209	25,467	20,568	—	—	CDC48Q8	5	870	49	5.64	3	21.5°	378	SR48	
86	39,162	37,352	35,207	32,664	30,448	—	—	CDC48R8	48	7 1/2	870	68	8.50	6	20°	428	SR48
87	32,064	30,247	28,224	26,105	23,829	21,625	19,483	CDC48Q11	5	1160	70	5.60	3	8.5°	319	S48	
88	39,344	37,422	35,328	32,792	30,462	28,136	25,773	CDC48R11	7 1/2	1160	80	8.47	3	14°	359	SR48	
89	44,737	42,565	40,131	37,704	35,346	32,752	29,347	CDC48S11	10	1160	81	11.33	3	18.5°	395	Note 6	
90	45,574	44,428	43,220	41,852	40,456	39,127	37,690	CDC48T17	15	1750	142	16.76	3	7°	359	Note 6	
91	49,629	48,619	47,609	46,599	45,581	44,500	43,422	CDC48U17	20	1750	161	22.17	4	7.5°	395	Note 6	

(chart continues next page)

ALL SPECIFICATIONS SUBJECT TO CHANGE WITHOUT NOTICE

Type CDC Performance Ratings (cont'd)

Item No.	Cubic Feet Per Minute (CFM) at Static Pressure ^{1,8}							Fan Model ²	Fan Size	Motor HP	Fan RPM	Sone Rating ³	Max BHP ^{4,6}	Blade No.	Descr. Pitch	Approx. Ship Wt.	Shutter Model ⁵
	0"	1/8"	1/4"	3/8"	1/2"	5/8"	3/4"										
92	26,200	22,089	17,992	—	—	—	—	CDC54M6	1 1/2	680	37	1.73	3	8.5°	375	S54	
93	29,639	25,602	20,796	14,890	—	—	—	CDC54N6	2	680	39	2.27	3	12°	397	S54	
94	32,293	29,264	26,144	22,614	18,652	—	—	CDC54P8	3	870	54	3.33	3	7.5°	393	S54	
95	41,756	37,845	35,237	30,261	26,772	23,053	—	CDC54Q8	5	870	61	5.82	3	15°	443	SR54	
96	48,304	45,458	42,027	35,213	30,889	26,860	—	CDC54R8	54	7 1/2	870	67	8.61	3	22°	473	SR54
97	43,875	41,864	39,351	36,781	34,602	32,118	29,100	CDC54R11	7 1/2	1160	94	8.28	3	8°	439	SR54	
98	50,560	48,007	45,916	43,404	39,866	37,179	35,111	CDC54S11	10	1160	103	11.36	3	12°	473	SR54	
99	58,018	56,403	54,597	52,499	49,742	47,262	45,173	CDC54T11	15	1160	128	17.41	4	14.5°	500	Note 6	
100	31,795	26,932	21,425	16,194	—	—	—	CDC60N6	2	680	40	2.29	3	6°	412	S60	
101	37,877	32,608	27,882	21,251	—	—	—	CDC60P6	3	680	48	3.44	3	11°	492	S60	
102	43,820	39,639	36,142	32,648	27,552	23,321	—	CDC60Q8	5	870	66	5.78	3	8°	452	S60	
103	52,955	49,203	44,663	40,761	35,890	28,254	—	CDC60R8	60	7 1/2	870	80	8.71	3	14°	484	SR60
104	54,238	51,001	48,093	45,745	43,499	40,386	35,960	CDC60S11	10	1160	104	11.38	3	6°	480	SR60	
105	61,427	59,014	56,886	55,040	52,871	49,802	46,550	CDC60T11	15	1160	123	16.81	4	7.5°	510	SR60	

- 1 — Performance certified is for Installation Type A: free inlet, free outlet. Performance ratings do not include the effects of appurtenances (accessories).
- 2 — The first three letters of the model number identify **fan type, drive configuration and style**. The next two numbers indicate **fan size**, the next letter identifies **motor horsepower**, the last number (or numbers) indicates **RPM** in hundreds. For example: Model CDC24G8 is Type "C", direct drive, Style "C", 24" size, 1/4 H.P., 870 RPM.
- 3 — The sound ratings shown are loudness values in hemispherical sones at 1.5m (5 ft.) in a hemispherical free field calculated per AMCA Standard 301. Values shown are for Installation Type A: free inlet hemispherical sone levels. The sound ratings shown are at 0" static pressure.
- 4 — Maximum brake horsepower (BHP) within the catalog performance range. Power rating (BHP) does not include transmission losses. Bearing losses are included. BHP at most static pressures listed is less than that shown, in some cases substantially less. For specific BHP values at individual static pressure points contact your American Coolair representative. Because of the cooling the motor receives from the moving air stream, motor loading beyond the nominal nameplate ratings on these American Coolair fans does not overheat the motor and is within NEMA recommended limits and motor service factor. It is not detrimental to the motor and is economically desirable.
- 5 — Shutter models shown are automatic (gravity) type. Add suffix "M" for manual operation; suffix "E" for motor operation.
- 6 — Consult factory for these shutter specifications.
- 7 — Manually adjustable variable speed controller is available as an option on these models, exhaust and supply. Control provides infinite variation of motor speed from full speed, which is RPM shown, to 50% of full speed. It is available only with single-phase, 115V or 230V motors. Specify "variable speed control" when this accessory is desired.
- 8 — To convert air performance (CFM and SP) and power (BHP) to metric units, multiply CFM x .000472 to obtain cubic meters per second (m³/s). Multiply SP x 248.36 to obtain pascals (Pa). Multiply BHP x .7457 to obtain kilowatts (kW).

Example: 3904 CFM x .000472 = 1.8427 m³/s
0.125 SP x 248.36 = 31.05 Pa
0.886 BHP x .7457 = 0.661 kW

ALL SPECIFICATIONS SUBJECT TO CHANGE WITHOUT NOTICE

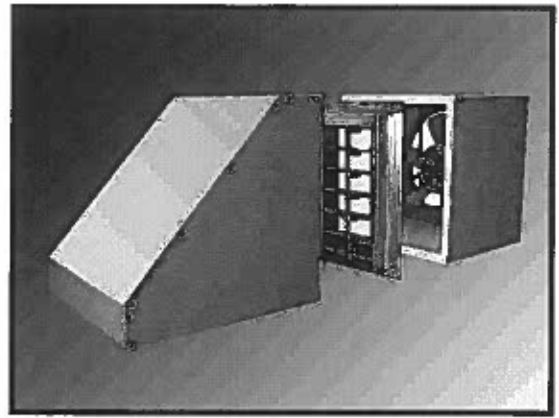
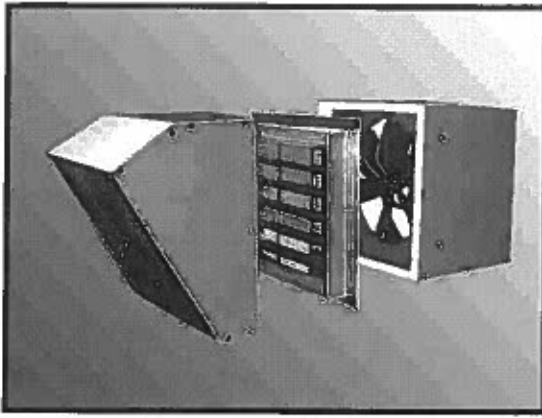

OPTIONAL FAN PACKAGE COMPONENTS

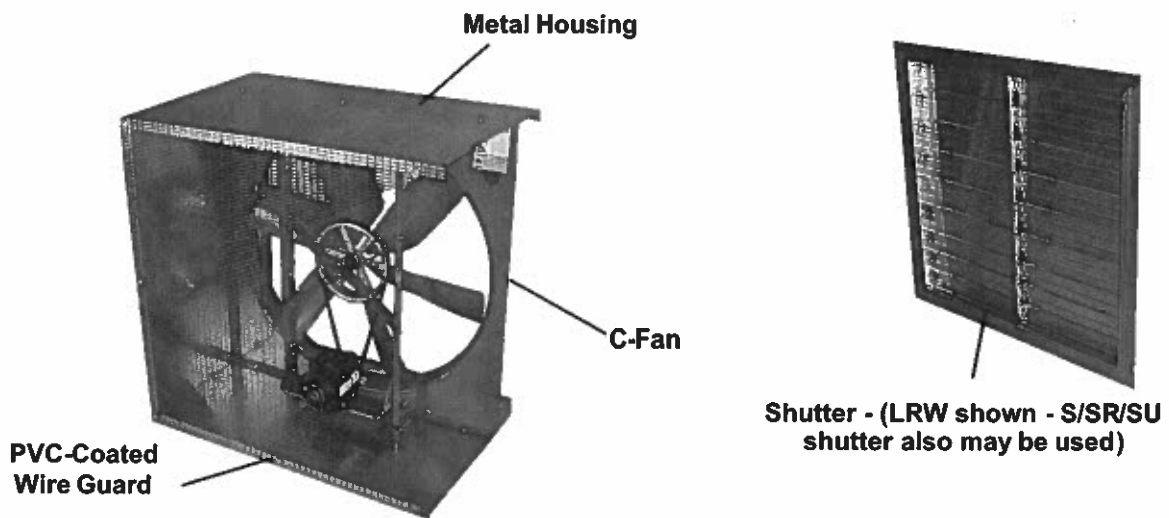

ACCESSORIES FOR FAN PACKAGES

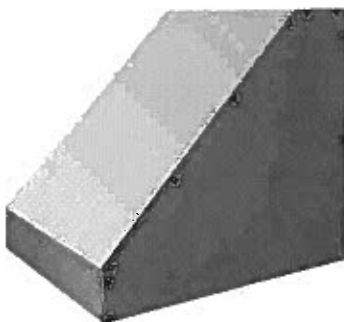

INLET HOOD OPTION

- Specifically designed for supply applications
- Designed to prevent entrainment of moisture into the airstream
- Hardware kit included for ease of assembly
- PVC-coated wire guard available
- Wide range of sizes to fit every need

DISCHARGE HOOD OPTION

- Specifically designed for exhaust applications
- Designed for all-weather performance with minimal pressure losses
- Hardware kit included for ease of assembly
- PVC-coated wire guard available
- Wide range of sizes to fit every need

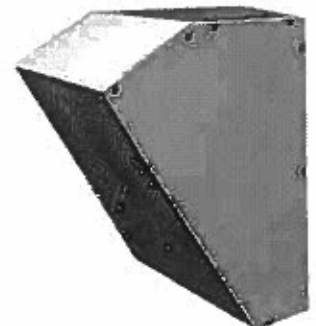

MOUNTING FLANGE OPTION

- For mounting inlet hood or discharge hood to the wall
- For mounting metal housing to the wall
- Hardware kit included for attaching to hood or fan housing

Accessory Dimensions

Dimension A is the OD of the square metal housing, excluding hardware.
 Dimension B is the length of the metal housing.
 Dimension C is the OD of the shutter frame.

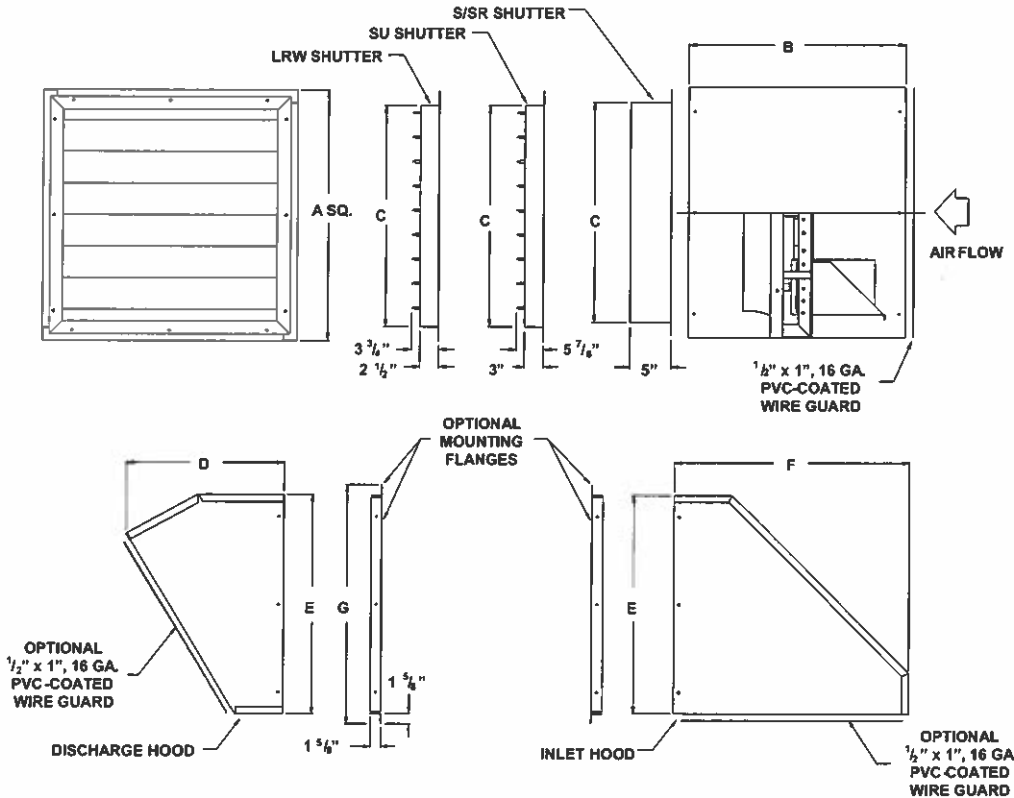

STYLE	UNIT SIZE	DIMENSIONS IN INCHES							METAL GAUGES		WALL OPENING	
		A SQ.	B	C		D	E	F	G	HSG		HOOD
MH	7-8	14 1/2	16 1/2	10 1/2	13	14 1/2	15 1/2	17 1/2	20	22	15 SQ.	
MH	10-12	18 1/2	21 1/2	14 1/2	15	18 1/2	19 1/2	21 1/2	20	22	19 SQ.	
MH	14-16	22 1/2	25 3/8	18 1/2	17	22 1/2	23 1/2	25 1/2	20	22	23 SQ.	
MH	18-20	26 1/2	25 3/8	22 1/2	19	26 1/2	27 1/2	29 1/2	20	22	27 SQ.	
MH	24	32 1/2	26 3/8	27	28 3/8	22	32 1/2	33 1/2	35 1/4	20	20	33 SQ.
MH	30	38 1/2	26 3/8	33	34 3/8	24 3/8	38 1/2	39 1/2	41 3/8	20	20	39 SQ.
MH	36	44 1/2	32 3/8	39	40 3/8	27 3/8	44 1/2	45 1/2	47 3/8	18	18	45 SQ.
MH	42	50 1/2	32 3/8	45	46 3/8	30 1/2	50 1/2	51 1/2	53 3/8	18	18	51 SQ.
MH	48	56 1/2	32 3/8	51	52 3/8	32 3/8	56 1/2	57 1/2	59 3/8	18	18	57 SQ.
MHX	48	56 3/8	44 1/2	56 3/8	44 1/2	59 1/2	18	57 1/2 SQ.				
MHX	48	56 3/8	44 1/2	56 3/8	44 1/2	59 1/2	12	57 1/2 SQ.				
MHRI	54	62 3/8	32 3/8	57	58 3/8	35 3/8	62 1/2	63 1/2	65 3/8	14	18	63 1/2 SQ.
MHX	54	62 3/8	44 1/2	62 3/8	44 1/2	65 3/8	12	63 1/2 SQ.				
MHI	60	68 3/8	32 3/8	64 3/8	35 3/8	68 1/2	69 1/2	71 3/8	14	18	69 1/2 SQ.	
MHX	60	68 3/8	44 1/2	68 3/8	44 1/2	71 1/2	12	69 1/2 SQ.				
MHX	72	80 3/8	45 1/4	80 3/8	45 1/4	84	10	81 1/2 SQ.				
MHX	84	92 3/8	45 1/4	82 3/8	45 1/4	86	10	83 1/2 SQ.				

Limited Warranty

In the sale of its products, American Coolair Corporation agrees to correct, by repairs or replacement, any defects in workmanship or material that may develop under proper and normal use during the period of one year from the date of shipment from the factory. Any product or part proving, upon American Coolair's examination, to be defective during limited warranty period will be repaired or replaced, at American Coolair's option, f.o.b. factory, without charge.

Deterioration or wear caused by chemicals, abrasive action or excessive heat shall not constitute defects.

Motors are guaranteed only to the extent of the manufacturer's warranty.

American Coolair's limited warranty does not apply to any of its products or parts that have been subject to accidental damage, misuse by the user, unauthorized modifications, improper installation or electrical wiring, or lack of proper lubrication or other service requirements as established by American Coolair.

Repairs or replacements provided under the above terms shall constitute fulfillment of all American Coolair's obligations with respect to limited warranty. THE LIMITED WARRANTY STATED HEREIN IS IN LIEU OF ALL OTHER WARRANTIES, EXPRESS, STATUTORY OR IMPLIED, INCLUDING WITHOUT LIMITATION THAT OF MERCHANTABILITY AND FITNESS. NO LIABILITY FOR REINSTALLATION COST OR FOR ANY SPECIAL, INDIRECT OR CONSEQUENTIAL DAMAGES OF ANY NATURE IS ASSUMED OR SHALL BE IMPOSED UPON AMERICAN COOLAIR.

Accessory Dimensions

Dimension D is the overall length of the discharge hood.
 Dimension E is the overall height of the discharge and inlet hoods.
 Dimension F is the overall length of the inlet hood.
 Dimension G is the overall height of the mounting flanges.

WARNING

CAUTION

DO NOT INSTALL FAN WITH MOVING PARTS WITHIN 8 FEET OF FLOOR OR GRADE LEVEL WITHOUT A GUARD THAT COMPLIES WITH OSHA REGULATIONS. **DO NOT** USE UNLESS ELECTRICAL WIRING COMPLIES WITH ALL APPLICABLE CODES. **DO NOT** WIRE WITHOUT PROVIDING FOR A POWER SOURCE DISCONNECT AT THE FAN ITSELF. **DO NOT** SERVICE EXCEPT BY A QUALIFIED MAINTENANCE TECHNICIAN AND ONLY AFTER DISCONNECTING THE POWER SOURCE. FAILURE TO OBSERVE THESE PRECAUTIONS CAN RESULT IN SERIOUS INJURY OR DEATH.

REPRESENTED BY:



AMERICAN COOLAIR CORPORATION
 P.O. BOX 2300 - Jacksonville, Florida 32203
 Phone: (904) 389-3646
 Fax: (904) 387-3449 or (904) 381-7560
 E-mail: fans@coolair.com