

MODEL EA-662-HSL

Severe Weather Louver • 6" Deep • Chevron Blades • Horizontal • Rain Resistant • Extruded Aluminum

Standard Materials and Construction

FRAME: .081" thick (nominal) extruded aluminum, 6063-T52/T6 alloy
BLADE: .081" thick (nominal) extruded aluminum, 6063-T52/T6 alloy.
 Blades approximately 1.625" on centers.

LOUVER FACE: Head and blades are contained within jambs.

DRAIN PAN: .060" thick (nominal) formed aluminum.

SCREEN: (When indicated, in a removable frame.)

- or- 1/2" flattened aluminum (.051" thick),
- or- 1/2" sq. mesh, intermediate double-crimped aluminum wire, .063" dia.,
- or- 1 5/16 mesh, .011" dia. aluminum wire, insect screen.

FINISH: Mill

Options

Finish - Baked Enamel, Kynar, Anodize

Notes

1. Nominal deductions will be made to the opening size given.
2. Louvers larger than the maximum factory assembled size will require field assembly of smaller louver sections.
3. Approximate shipping weight is 7.0 lbs./sq.ft.

Louver Sizes

Min Panel	Max Single Panel
12"W x 12"H	30 sq.ft.

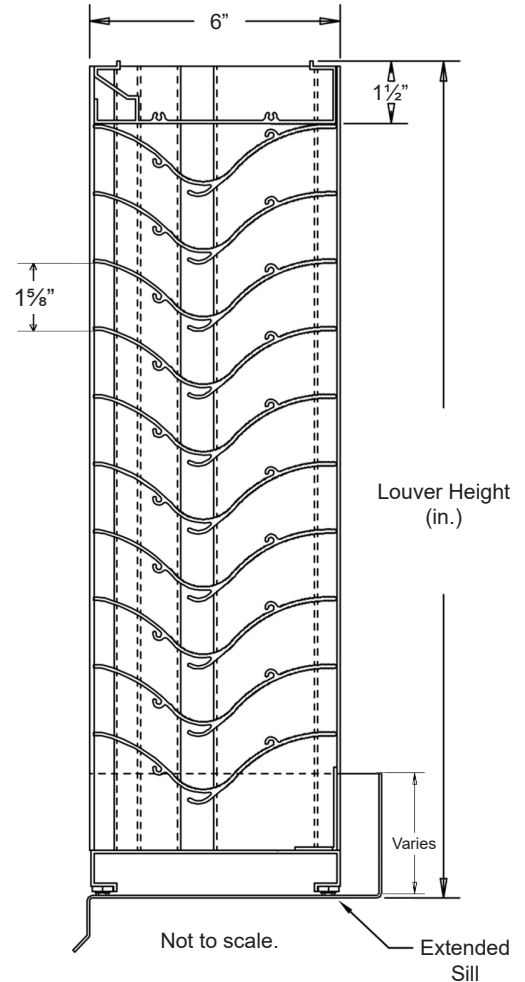
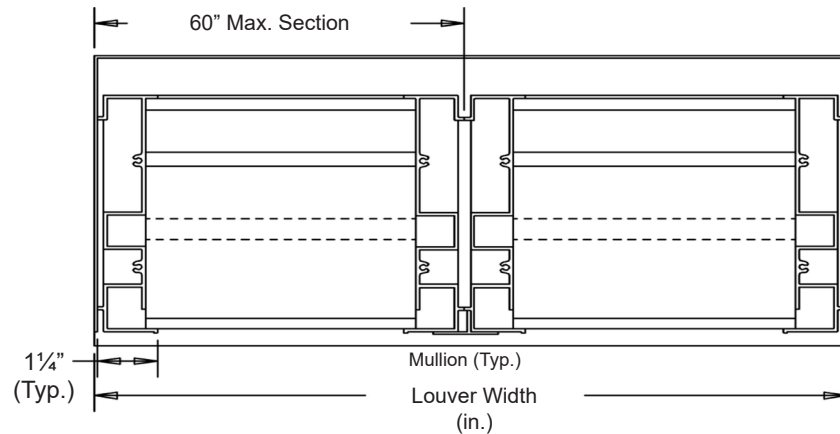

Item #	Qty	Width	Height	Width	Height	Mullion	Type	Location	Union Made
		Opening Size		Louver Size			Screens		
Arch. / Eng.:						EDR:		ECN:	Job:
Contractor:									
Project:						Date:		DWN:	DWG:



MODEL EA-662-HSL

Severe Weather Louver • 6" Deep • Chevron Blades • Horizontal • Rain Resistant • Extruded Aluminum

Performance Data

Pressure Drop: .10 in. w.g. at 925 fpm (intake)
 Free Area: 8.14 sq.ft. = 51% for 48"W x 48"H sample tested in accordance with AMCA Standard 500-L.

Beginning Point of Water Penetration: Over 1250 fpm

Class "A" Rating with 99.0% efficiency at 3 in. rain fall at intake velocity of 239 fpm (1,945 cfm) at wind speed of 29 mph.

Class "B" Rating with 95.3% efficiency at 8 in. rain fall at intake velocity of 328 fpm (2,670 cfm) at wind speed of 50 mph.

Testing based on 48" x 48" based on AMCA Standard 500-L.

Ratings do not include effects of a screen.

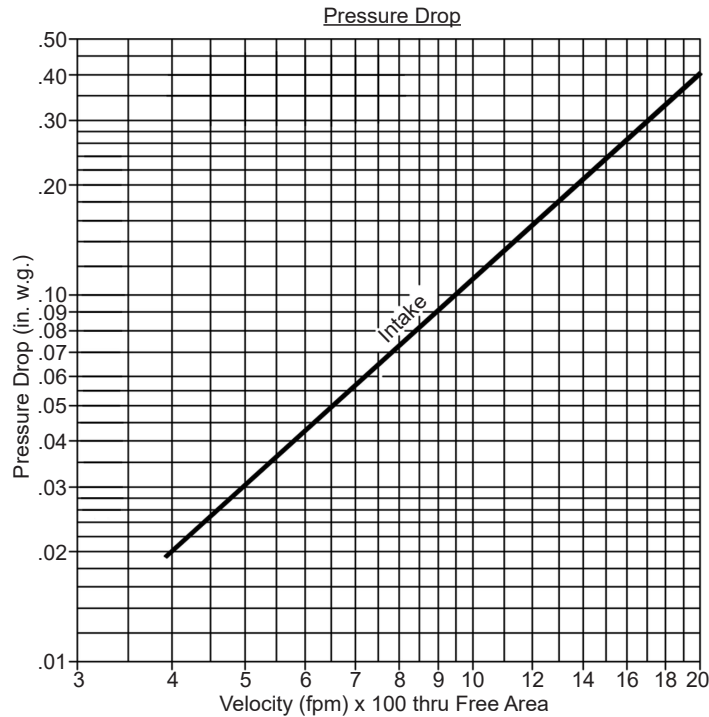

Intake air converted to standard air density.
 Tested to AMCA Standard 500-L, Figure 5.5.

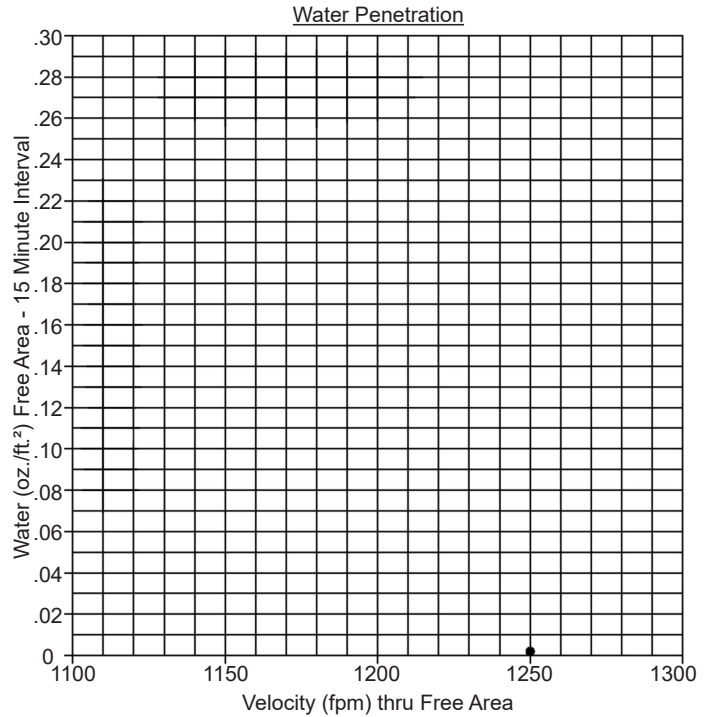

The Beginning Point of Water Penetration is above 1250 fpm through the free area of the louver.

AMCA Standard 500-L limits testing of water penetration to either a maximum velocity of 1250 fpm or 2.5 ounces of water per square foot of louver free area.

		Free Area (sq.ft.)									
		Width (in.)									
		12"	24"	36"	48"	60"	72"	84"	96"	108"	120"
Height (in.)	12"	.29	.65	1.02	1.39	1.75	2.12	2.49	2.85	3.22	3.59
	24"	.76	1.73	2.70	3.67	4.64	5.61	6.58	7.56	8.53	9.50
	36"	1.24	2.82	4.41	5.99	7.58	9.16	10.75	12.33	13.92	15.50
	48"	1.68	3.84	5.99	8.14	10.29	12.45	14.60	16.75	18.91	21.06
	60"	2.16	4.91	7.67	10.43	13.19	15.95	18.71	21.46	24.22	26.98
	72"	2.60	5.93	9.26	12.59	15.92	19.24	22.57	25.90	29.23	32.56
	84"	3.08	7.02	10.95	14.89	18.83	22.77	26.71	30.64	34.58	38.52
	96"	3.49	7.96	12.42	16.89	21.35	25.82	30.28	34.75	39.21	43.68
	108"	3.93	8.97	14.00	19.04	24.07	29.10	34.14	39.17	44.21	49.24
	120"	4.41	10.05	15.68	21.32	26.96	32.60	38.24	43.88	49.52	55.16

MODEL EA-662-HSL

Severe Weather Louver • 6" Deep • Chevron Blades • Horizontal • Rain Resistant • Extruded Aluminum Page 3

Wind Driven Rainwater Penetration Test
Conducted to AMCA Standard 500-L.

Test size 1m x 1m (39.7" x 39.7") core area, 41.88" x 41.75" nominal.
Louver Free Area 6.13 square feet.

Core Ventilation (m/s)	0.0	0.5	1.0	1.5	2.0	2.5	3.0	3.5	4.0	4.5	5.0	Rain Fall / MPH 3 in. / hr. rain fall and 29 mph Velocity
FPM	0	136	189	279	372	474	591	685	797	879	986	
Free Area Ventilation (cfm)	0	1,464	2,030	3,000	4,004	5,106	6,360	7,377	8,585	9,459	10,612	
Free Area Velocity (fpm)	0	239	331	489	653	833	1,038	1,203	1,400	1,543	1,731	
Effective Rating Class	A	A	B	B	B	B	B	B	C	D	D	
Effective Ratio %	99.1	99.0	98.9	98.7	98.6	98.2	97.6	95.4	88.6	77.2	60.7	8 in. / hr. rain fall and 50 mph Velocity
FPM	0	99	187	275	392	491	578	688	789	878	967	
Free Area Ventilation (cfm)	0	1,061	2,013	2,962	4,216	5,287	6,221	7,413	8,491	9,545	10,414	
Free Area Velocity (fpm)	0	173	328	483	688	862	1,015	1,209	1,385	1,542	1,699	
Effective Rating Class	B	B	B	C	C	C	C	C	D	D	D	
Effective Ratio %	97.1	96.0	95.3	94.2	92.1	90.3	87.3	82.0	78.3	74.5	71.2	

Wind Driven Rain Penetration Classifications

Class	Effectiveness %
A	100 to 99%
B	98.9% to 95%
C	94.9% to 80%
D	Below 80%

Discharge Loss Coefficient Classifications

Class	Discharge Loss Coefficient
1	0.4 and above
2	0.3 to 0.399
3	0.2 to 0.299
4	0.199 and below

$$\frac{\text{Discharge Coefficient}}{\text{Intake Cd} = 0.44 \text{ (Class 1)}}$$

Class 1 Loss Coefficient has the least resistance to airflow.

1. Core area is the front opening of a louver assembly with the blades removed.
2. Core area velocity is the airflow rate through the louver divided by the core area (39.37" x 39.37").
3. Free area is the minimum area through which air can pass. It is determined by multiplying the sum of the minimum distance between intermediate blades, top blade and head, bottom blade and sill, by the minimum distance between jambs.
4. Discharge loss coefficient is calculated by dividing a louver actual airflow rate vs. a theoretical airflow for the opening, providing an indication of the louver air flow characteristics.



Arrow United Industries certifies that the Model EA-662-HSL shown herein is licensed to bear the AMCA seal. The ratings shown are based on tests and procedures performed in accordance with AMCA Publication 511 and comply with the requirements of the AMCA Certified Ratings Program. The AMCA Certified Ratings Seal applies to Water Penetration, Air Performance, and Wind Driven Rain Ratings only.