



INDUSTRIAL PROCESS AND  
COMMERCIAL VENTILATION SYSTEMS

# UPBLAST & HOODED TUBEAXIAL ROOF VENTILATORS

TUB | TUD | TUBSH | THB | THD | THBF | THDF



# TUBEAXIAL ROOF VENTILATORS



## Overview

**TUB | TUD | TUBSH | THB |  
THD | THBF | THDF**



Model TUB

Twin City Fan & Blower Tubeaxial Roof Ventilators provide cost effective, general-purpose ventilation of commercial buildings. Belt and direct drive models are available with adjustable pitch, cast aluminum or fixed pitch, fabricated steel impellers to meet specific application requirements.

### Typical Industries Include

Agriculture, Air Pollution Control, Automotive, Boilers, Brick, Car Wash, Commercial Plan & Spec, Composting, Ethanol, Food & Beverage, Foundry, General Manufacturing, Glass, Green/LEED, HVAC, Institutional & Hospitality, Metal & Minerals, Microchip, Mining, Nuclear, OEM, Petrochemical, Pharmaceutical, Power Generation, Pulp & Paper, Recycling, Textile, Transportation

### Configurations

Upblast, Hooded, Hooded Filtered

### Impeller Types

"L1" and "L2" Fabricated Steel Impellers; "B" and "E" Die Cast Aluminum Impellers; "C" Cast Aluminum Impellers; "Z" Fabricated Steel Impellers

### Standard Construction

Heavy-Gauge Galvanized Steel

### Optional Construction

Special Coatings, Spark 'B' Resistant (Belt Driven Only), UL 705, UL Smoke & Heat

### Certifications

AMCA Sound/Air and FEI, UL 705 Listed for Electrical, UL Listed for Smoke Control Systems



For complete product performance, drawings and available accessories, download our Fan Selector software at [tcf.com](http://tcf.com).



All models are cULus 705 listed, for electrical, File No. E158680.

Model TUBSH is UL listed for Smoke Control Systems, 500°F for 4 hours and 1000°F for 15 minutes.



Twin City Fan & Blower, a Twin City Fan Company, certifies that the TUB/TUD/TUBSH Series shown herein is licensed to bear the AMCA Seal. Certified performance data may be found in Twin City Fan & Blower's Fan Selector software.



Fan Energy Index (FEI) certification applies to Model TUB Sizes 24E4, 24E8, 24Z5, 30E4, 30E8, 30Z5, 36E4, 36E8, 36Z5, 42E4, 42E8, 42Z5, 48E4, 48E8, 48Z5, 54C3, 54C6, 54Z5, 60C3, 60C6, 60Z5, 14B105, 16B105, 18B105, 21B105, 24B105, 30B105, 36B206, 42B304, 48B304 and 54B406; Model TUBSH Sizes 24Z5, 30Z5, 36Z5, 42Z5, 48Z5, 54Z5 and 60Z5; and Model TUD Sizes 21E4, 24E4, 24E8, 30E4, 30E8, 36E4, 36E8, 42E4, 42E8, 48E4, 48E8, 14B105, 16B105, 18B105, 21B105, 24B105, 30B105, 36B206, 42B304 and 48B304.



Fan Energy Index (FEI) certification applies to Model THB Sizes 14B105, 16B105, 18B105, 21B105, 24B105, 30B105, 36B206, 42B304, 48B304 and 54B406; Model THBF Sizes 21B105, 24B105, 30B105, 36B206, 42B304, 48B304 and 54B406; Model THD Sizes 14B105, 16B105, 18B105, 21B105, 24B105, 30B105, 36B206, 42B304 and 48B304; and Model THDF Sizes 21B105, 24B105, 30B105, 36B206, 42B304 and 48B304.



Scan the QR code to search Twin City Fan & Blower's AMCA-certified products.

## Overview

**TUB | TUD | TUBSH | THB |  
THD | THBF | THDF**

### Upblast

#### TUD (Direct Drive)

14" to 48" impeller diameters  
Airflow to 39,100 CFM  
Static pressure to 1.5" w.g.



#### TUB (Belt Driven)

14" to 60" impeller diameters  
Airflow to 72,400 CFM  
Static pressure to 1.5" w.g.



### Hooded

#### THD (Direct Drive)

14" to 48" impeller diameters  
Airflow to 36,400 CFM  
Static pressure to 1.5" w.g.



#### THB (Belt Driven)

14" to 60" impeller diameters  
Airflow to 63,800 CFM  
Static pressure to 1.5" w.g.



### Hooded Filtered Supply

#### THDF (Direct Drive)

21" to 48" impeller diameters  
Airflow to 36,400 CFM  
Static pressure to 1.5" w.g.



#### THBF (Belt Driven)

21" to 60" impeller diameters  
Airflow to 63,800 CFM  
Static pressure to 1.5" w.g.



### Smoke & Heat Removal

#### TUBSH (Belt Driven)

24" to 60" impeller diameters  
Airflow to 70,700 CFM  
Static pressure to 1.5" w.g.



### Temperature Rating

500°F for 4 Hours  
1000°F for 15 Minutes

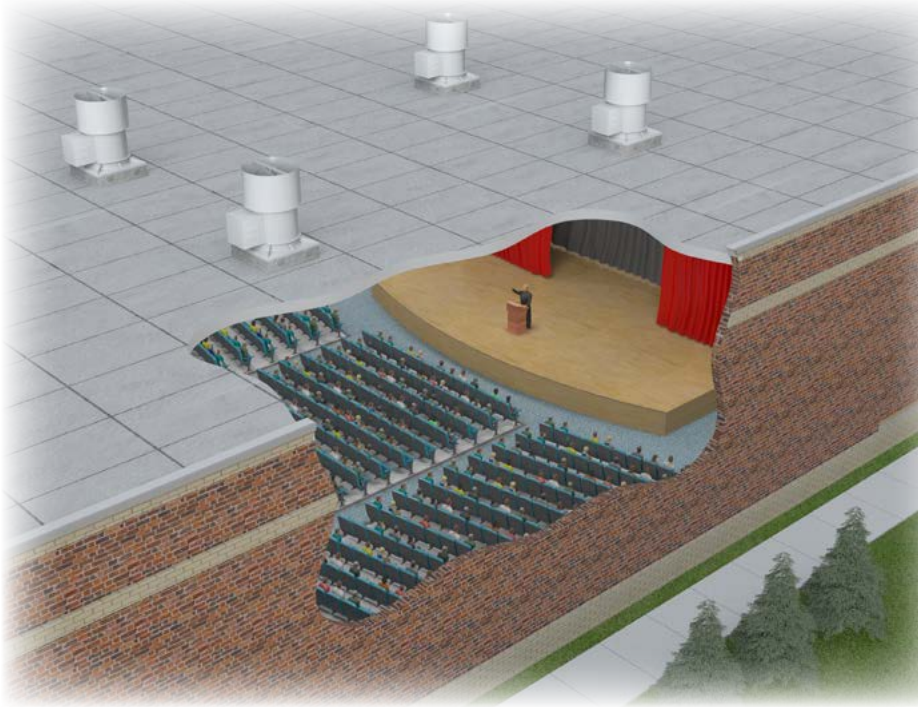

Auditorium Ventilation  
with Model TUBSH

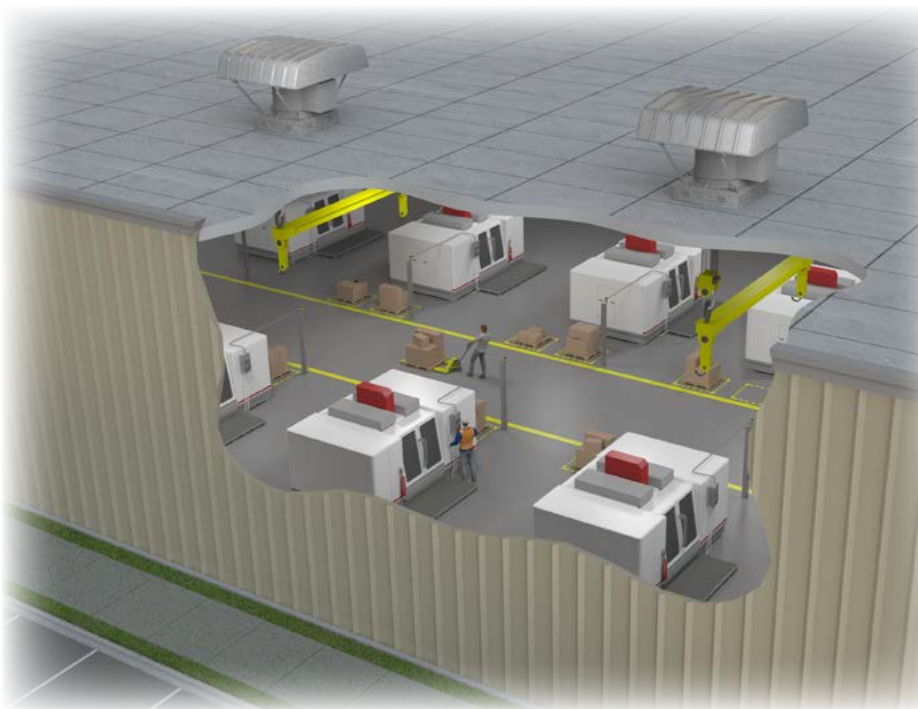

Manufacturing Floor Ventilation  
with Model THB





## Upblast

TUB | TUD | TUBSH



Model TUD

### Models TUB & TUD (Upblast)

Upblast models TUB and TUD include a heavy-duty, galvanized steel stack cap with butterfly dampers to discharge air upward and prevent recirculation into the building. A splash guard located over the damper pivot area protects against rain entry.

### Sizes

TUD Direct Drive - 14" to 48" impeller diameters  
TUB Belt Driven - 14" to 60" impeller diameters

### Performance

TUD Direct Drive - Airflow to 39,100 CFM  
TUB Belt Driven - Airflow to 72,400 CFM  
Static pressure to 1.5" w.g.

### Model TUBSH (Smoke & Heat Removal - Upblast)

Smoke and heat removal model TUBSH is designed to remove smoke from buildings in the event of a fire. The unit features fusible link damper springs, which force dampers to open when the fusible links melt at 165°F.

The TUBSH is designed to meet the time/temperature standards (500°F for 4 hours, 1000°F for 15 minutes) and snow load test for dampers set forth by UL, IRI and SBCCI.

### Sizes

24" to 60" impeller diameters

### Performance

Airflow to 70,700 CFM  
Static pressure to 1.5" w.g.



Model TUBSH



## Hooded

THB | THD | THBF | THDF

### Models THB & THD (Hooded)

Hooded models THB (belt driven) and THD (direct drive) are available in exhaust or supply configurations and feature a removable galvanized steel hood for cleaning and servicing, as well as a galvanized steel bird screen. Hoods on fan sizes 48, 54 and 60 ship knocked down and require field assembly.

### Sizes

THD Direct Drive - 14" to 48" impeller diameters  
THB Belt Driven - 14" to 60" impeller diameters

### Performance

THD Direct Drive - Airflow to 36,400 CFM  
THB Belt Driven - Airflow to 63,800 CFM  
Static pressure to 1.5" w.g.



Model THB

### Models THBF & THDF (Hooded Filtered Supply)

Hooded filtered supply models THDF (direct drive) and THBF (belt driven) feature a removable galvanized steel hood for cleaning and servicing the fan as well as 2" washable aluminum mesh filters. Hoods on fan sizes 42, 48, 54 and 60 ship knocked down and require field assembly.

### Sizes

THDF Direct Drive - 21" to 48" impeller diameters  
THBF Belt Driven - 21" to 60" impeller diameters

### Performance

THDF Direct Drive - Airflow to 36,400 CFM  
THBF Belt Driven - Airflow to 63,800 CFM  
Static pressure to 1.5" w.g.



Model THDF

## Energy Regulations

Twin City Fan & Blower supports energy efficiency regulations enacted by the U.S. Department of Energy (DOE) and specific states. The selection and application of fan products is a significant part of these regulations. Engineers and specifiers must understand how to apply TCF products to their specific applications to meet applicable DOE and state regulatory requirements. Twin City Fan & Blower has made significant investments in product testing and development to provide efficient products. Developments in Twin City Fan & Blower's Fan Selector software are in place to aid your decision in product selection to assist with meeting the efficiency requirements as stipulated in the applicable regulations.

# IMPELLER COMPARISON

FAN SIZE	DIRECT DRIVE	BELT DRIVEN
14	B, E	—
16	B, E	—
18	B, E	—
21	B, E	L1, L2, B, E
24	B, E, Z	L1, L2, B, E, Z
30	B, E, Z	L1, L2, B, E, Z
36	B, E, Z	L1, L2, B, E, Z
42	B, E, Z	L1, L2, B, E, Z
48	B, E, Z	L1, L2, B, E, Z
54	—	L1, L2, B, C, Z
60	—	L1, L2, C, Z

Impeller Availability

Twin City Fan & Blower Tubeaxial Roof Ventilators are available with either fixed pitch fabricated steel or adjustable pitch cast aluminum impellers. Each impeller type is designed for a wide variety of commercial market applications with static pressure capabilities from 0" to 1 1/2". The TUBSH is available only with the fabricated steel impeller. Regardless of the application requirement, Twin City Fan & Blower impellers offer the right choice.



## "L1 & L2" Fabricated Steel Impellers

The "L1" and "L2" series features fixed pitch, fabricated steel, 5-bladed impellers. Galvanized steel impeller blades are riveted to galvanized steel hubs. Available in 8 sizes from 21" to 60" diameters in either standard L1 construction or reinforced L2 construction.



## "B" Die Cast Aluminum Impellers

The "B" series features a die cast aluminum impeller available in 4, 5 and 6 blade designs. Blade angles are factory set and mounted in a die cast aluminum hub. "B" impellers are available in 14" through 54" diameters.



## "E" Die Cast Aluminum Impellers

The "E" series features a die cast aluminum impeller available in 4 and 8 blade designs. Blade angles are factory set and mounted in a die cast aluminum hub. "E" impellers are available in 14" through 48" diameters.



## "C" Cast Aluminum Impellers

The "C" series is a cast aluminum impeller available in 4 and 6 blade designs, and is available in 54" and 60" diameters only. Blade angles are factory set and mounted in a cast aluminum hub.



## "Z" Fabricated Steel Impeller

The "Z" series features a fixed pitch, fabricated steel, 5-bladed impeller. Steel blades are continuously-welded to a heavy-gauge hub at the customer's selected blade angle. "Z" impellers are available in 24" through 60" diameters.

## Construction Features (Upblast)

- Painted steel windband on stack cap
- Aluminum (sizes 14" to 36") and galvanized steel (sizes 42" to 60") butterfly dampers on stack cap
- Heavy-duty, painted steel curb cap includes venturi inlet for efficient airflow and prepunched mounting holes for easy installation
- Motors are ball bearing type, available in ODP, TE and EXP with a variety of standard voltages
- Motor cover is standard on models TUB and TUBSH
- Extended lube lines are standard on belt driven fans
- Externally mounted conduit box on model TUD



## Construction Features (Hooded)

- Hood constructed of galvanized steel
- Bird screen made of galvanized steel (THB, THD)
- Filters, 2" washable aluminum mesh filters (THBF, THDF)
- Heavy-duty, painted steel curb cap includes venturi inlet for efficient airflow and prepunched mounting holes for easy installation
- Structural, galvanized steel frame provides strong support and mounting base for motor and drive
- Motors are ball bearing type, available in ODP, TE and EXP with a variety of standard voltages
- Motor cover is standard on models THB and THBF
- Extended lube lines are standard on belt driven fans
- Externally mounted conduit box on models THD and THDF





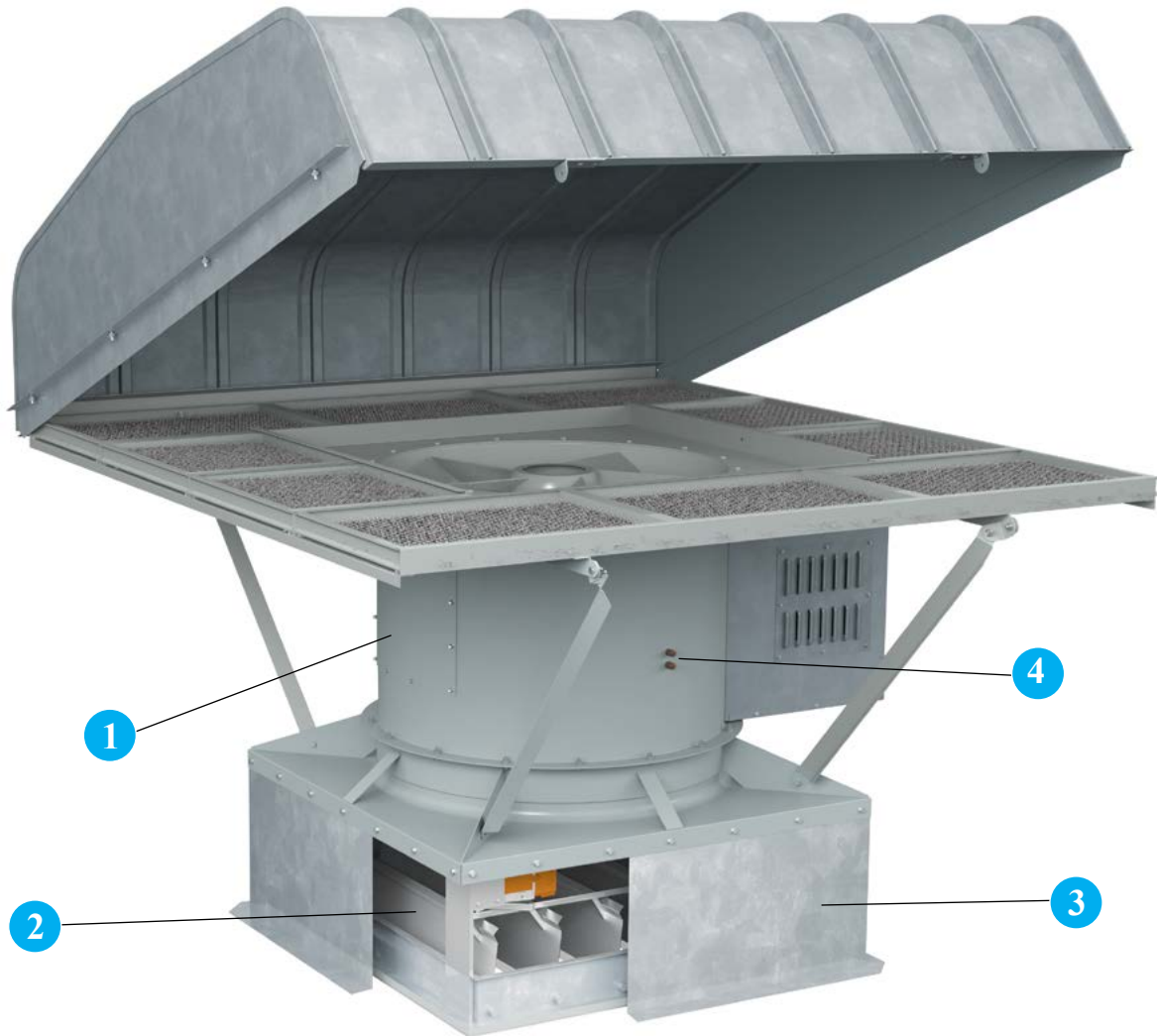

**1 Bolted Access Door** Heavy-duty bolted panel provides access for impeller inspection.

**2 Backdraft Damper (Hooded Only)** features a felt seal on the edge of the damper blades for quiet operation. Damper frames are constructed of 20-gauge galvanized steel and blades are constructed of 22-gauge aluminum.

Motorized dampers are recommended for low CFM applications to assure unrestricted airflow. Motorized dampers are available with 115, 208, 230, 460, 575 or 24 volt service; 208-575V service requires a step-down transformer. When a motorized damper option is selected a 12" (or greater) high roof curb is required.

**3 Self-Flashing Roof Curb** Prefabricated roof curbs are available in heavy-duty galvanized steel or aluminum construction, in heights of 8", 12" or 18". Curbs are provided with 1.5" of insulation as standard and feature continuously-welded seams for added rigidity and moisture protection. Prefabricated curbs are available in canted, self-flashing and straight-sided styles. See page 10 for further details on roof curb options. Minimum 12" high curbs are recommended for use with motorized dampers.

**4 Extended Lube Lines (Belt Driven Only)** Exterior mounting zerk fittings are available with lines to the fan shaft bearings (models TUB, TUBSH, THB, THBF) for relubrication from outside the unit. Standard on belt driven models.



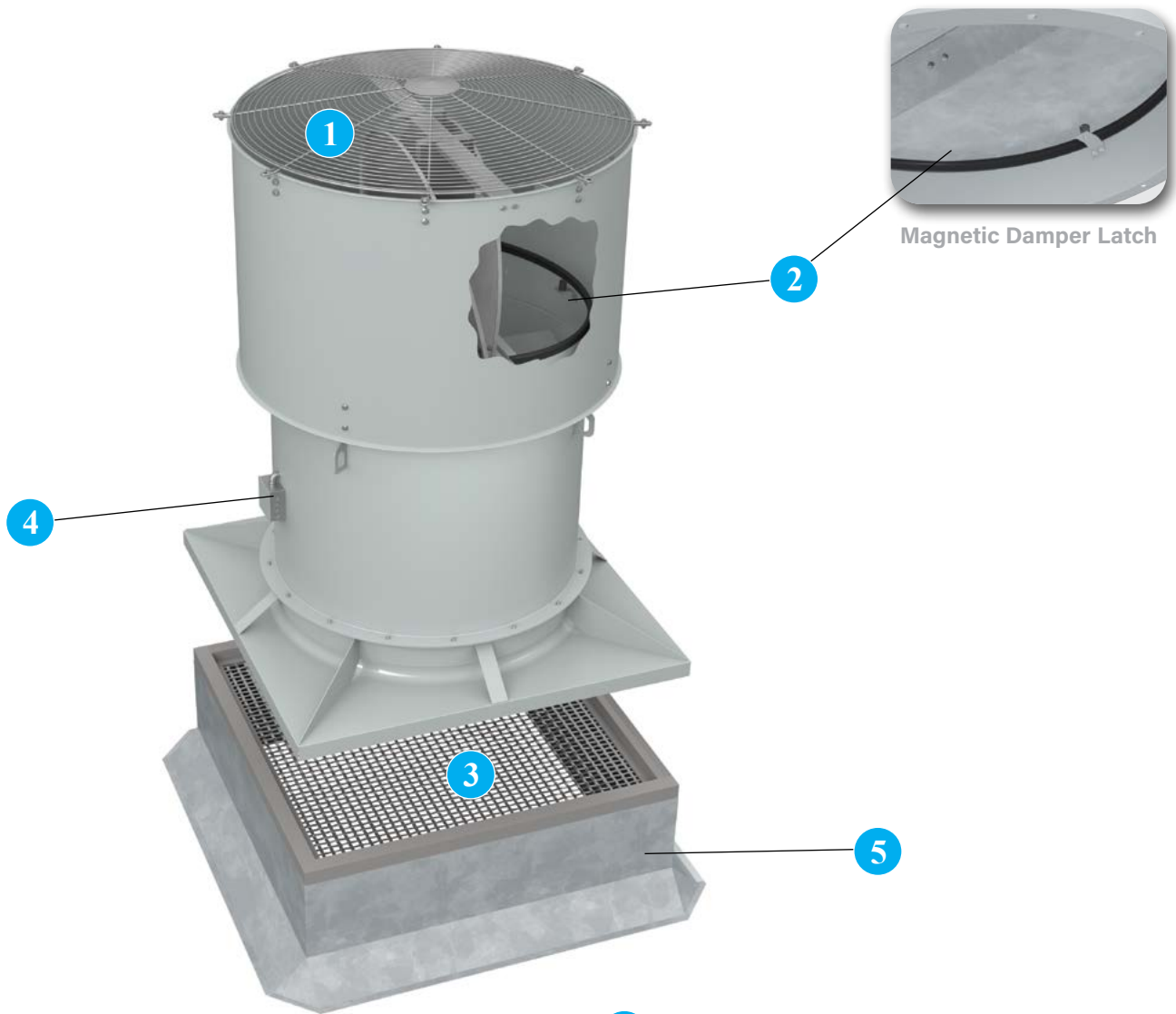

**1 Bird Screen/Outlet Guard** Protects the impeller, inlet and internal components from entry of birds. (Upblast only)

**2 Magnetic Damper Latches (Upblast Only)** Used to hold butterfly dampers closed when fan is not in operation. Damper blades must be steel.

**3 Inlet Safety Guard** A flat style guard to sit between the roof curb and the curb cap is available on all models. Twin City Fan & Blower recommends the use of an inlet safety screen on all non-ducted installations.

**4 Externally Mounted Conduit Box** Standard in direct drive models.

**5 Canted Roof Curb** Prefabricated roof curbs are available in heavy-duty galvanized steel or aluminum construction, in heights of 8", 12" or 18". Curbs are provided with 1.5" of insulation as standard and feature continuously-welded seams for added rigidity and moisture protection. See page 10 for further details on roof curb options.

### Other Accessories Include:

- Shaft Seal (TUB, THB and THBF only)
- Curb Extension with Damper Shelf
- Disconnect Switches (see page 11)
- Spark 'B' Construction (TUB, THB and THBF only)
- Fusible Link Butterfly Dampers (TUB, TUD, Standard on TUBSH)
- Special Coatings



## Canted Roof Curbs

- Constructed of 18-gauge galvanized steel with continuously-welded seams
- Large 3" built-in 45° cant to accommodate roofing material to top of curb. Cant is beveled at corners for better support of roofing material
- Wood nailer (1 1/2") secured to top ledge
- Lined with 1 1/2" fiberglass fire-resistant, sound-absorbing insulation
- Damper shelf standard
- Options: Aluminum (16-gauge) construction, burglar security bars, metal liner (galvanized or aluminum), special heights up to 24", single- or double-pitched curbs for sloping roofs



## Self-Flashing & Straight-Sided Roof Curbs

- Constructed of 18-gauge galvanized steel with continuously-welded seams
- Wide base plate (flashing) to ensure watertight seal to roof
- Top ledge covered with 3/16" polystyrene gasket (self-flashing) for weather seal and to reduce metal-to-metal conducted noise
- Wood nailer secured to top ledge (straight-sided)
- Lined with 1 1/2" fiberglass fire-resistant, sound-absorbing insulation
- Damper shelf standard
- Straight-sided roof curbs are constructed with the same features as the self-flashing curbs, but are one dimensional to allow for field supplied cants and roofing material to be brought up to the top of the curb
- Options: Aluminum (16-gauge) construction, burglar security bars, metal liner (galvanized or aluminum), special heights up to 24", single- or double-pitched curbs for sloping roofs



## Self-Flashing Vented Roof Curbs

### For High Temperature Applications

- Completely assembled unit, easier to install and less expensive than a field constructed curb
- Constructed of 18-gauge galvanized steel with continuously-welded seams and wide base flashing for watertight seal to roof
- Meets NFPA-96 code requirements
- Top ledge covered with 3/16" polystyrene gasket
- Furnished with ventilation slots



## Curb Adapters

- Constructed of heavy-gauge galvanized steel with continuously-welded seams
- Top ledge covered with 3/16" polystyrene gasket to reduce metal-to-metal conducted noise and act as a weather seal
- Available in enlarger or reducer (shown) models

Disconnect switches provide positive electrical shutoff during fan cleaning or maintenance.

### **NEMA 3R Disconnect Switch**

A NEMA 3R, rain proof, disconnect is available shipped loose for field mounting and wiring or factory mounted and wired externally.



NEMA 3R Disconnect Switch

### **NEMA 4 Disconnect Switch**

A NEMA 4, water and dust tight, disconnect is available shipped loose for field mounting and wiring or factory mounted and wired externally.



NEMA 4 Disconnect Switch

### **NEMA 7/9 Disconnect Switch**

A NEMA 7/9 disconnect switch is recommended on fans with explosion proof motors. The NEMA 7/9 switch is designed for use with fans operating in hazardous environments. Available shipped loose for field mounting and wiring. (Not shown.)

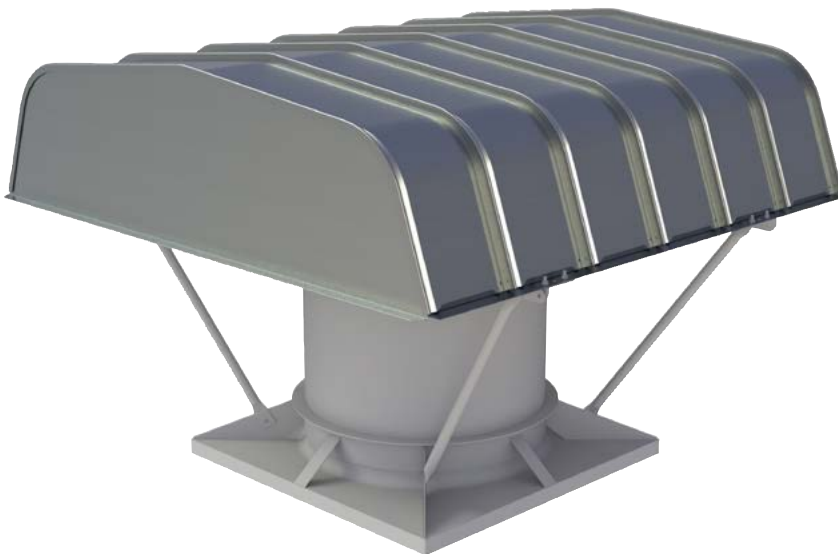

**Material Specifications**

FAN SIZE	GAUGES			IMPELLERS				SHAFT SIZE (IN.)	APPROX. SHIP WT. (LB)									
	WIND BAND	CURB CAP	HOOD	E	B	C	Z		TUB	TUD	TUBSH	THB	THD	THBF	THDF			
							HUB									BLADE		
14	20	16	22	DIE CAST ALUM.	DIE CAST ALUM.				3/4	74	67	N/A	123	116	N/A	N/A		
16	20	16	22						3/4	132	92	N/A	177	137	N/A	N/A	N/A	
18	20	16	22						3/4	169	133	N/A	222	186	N/A	N/A	N/A	
21	20	16	22						3/4	222	194	N/A	288	260	334	305		
24	20	16	22						12	14	1	292	213	292	421	342	466	389
30	20	16	22						12	14	1	419	369	419	558	508	701	601
36	20	16	22						12	12	1 <sup>3</sup> / <sub>16</sub>	589	517	589	783	711	857	785
42	20	16	22						10	10	1 <sup>7</sup> / <sub>16</sub>	724	639	724	884	799	955	868
48	20	14	22						10	10	1 <sup>7</sup> / <sub>16</sub>	1077	924	1077	1252	1099	1365	1210
54	18	14	22							CAST ALUM.	7	10	1 <sup>7</sup> / <sub>16</sub>	1345	N/A	1345	1539	N/A
60	18	14	22		CAST ALUM.	7	10	1 <sup>11</sup> / <sub>16</sub>	1609	N/A	1609	1929	N/A	2095	N/A			



**MODEL NOMENCLATURE**

**TUB - E - 24 - E - 4 - 16**

**Model**

- TUB = Upblast Tubeaxial Roof Ventilator, Belt Driven
- TUD = Upblast Tubeaxial Roof Ventilator, Direct Drive
- TUBSH = Smoke & Heat Removal Ventilator, Belt Driven
- THB = Hooded Tubeaxial Roof Ventilator, Belt Driven
- THD = Hooded Tubeaxial Roof Ventilator, Direct Drive
- THBF = Hooded Filtered Supply Tubeaxial Roof Ventilator, Belt Driven
- THDF = Hooded Filtered Supply Tubeaxial Roof Ventilator, Direct Driven

**E = Exhaust, S = Supply (THB/THD Only)**

**Fan Size**

**Impeller Type**

- Z = Fabricated Steel, Fixed Pitch (5-Bladed)
- E = Die Cast Aluminum, Adjustable Pitch (4- and 8-Bladed)
- C = Cast Aluminum, Adjustable Pitch (4- and 6-Bladed)
- B = Cast Aluminum, Adjustable Pitch (4-, 5- and 6-Bladed)

**No. of Blades**

**Impeller Blade Angle**



# Upblast

## Belt Driven - TUB/TUBSH

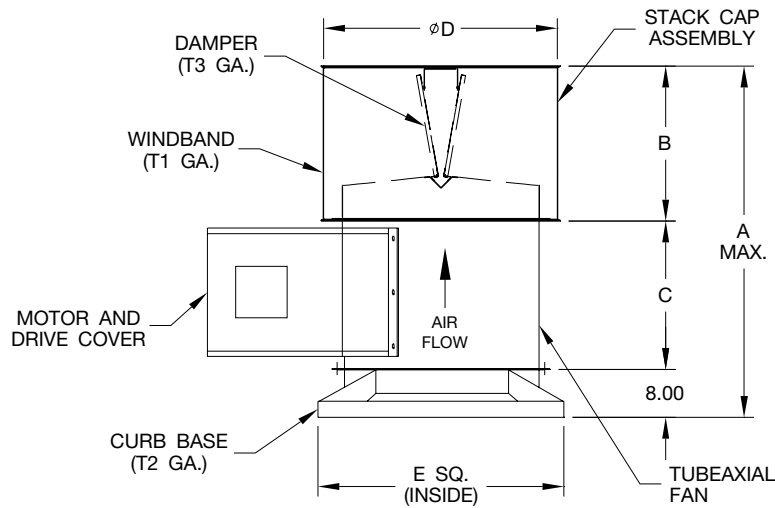

FAN SIZE	A MAX.	B	C	D	E	T1	T2	T3	SHAFT SIZE	MAX. FRAME
14	47.75	20.75	19.00	20.38	23.88	20	16	24	0.75	56
16	47.75	20.75	19.00	22.38	23.88	20	16	24	0.75	143T
18	48.75	21.75	19.00	25.38	27.88	20	16	24	0.75	145T
21	52.75	23.75	21.00	26.88	31.88	20	16	24	0.75	145T
24	53.75	24.75	21.00	28.88	35.88	20	16	24	1.00	184T
30	61.75	27.75	26.00	36.88	42.88	20	16	20	1.00	213T
36	65.75	30.75	27.00	42.88	48.88	20	16	20	1.19	215T
42	72.75	33.75	31.00	48.88	54.88	20	16	20	1.44	215T
48	79.75	36.75	35.00	54.88	60.88	20	14	20	1.44	254T
54	87.75	39.75	40.00	60.75	74.88	18	14	20	1.44	256T
60	91.75	43.75	40.00	66.75	74.88	18	14	20	1.69	284T

Dimensions are not to be used for construction.

D-4850-1C  
D-4850-5B

## Direct Drive - TUD

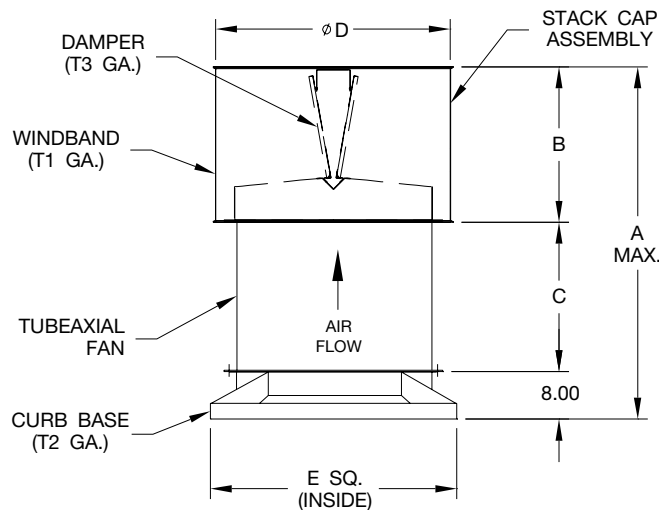

FAN SIZE	A MAX.	B	C	D	E	T1	T2	T3	MAX. HP	MAX. FRAME
14	47.75	20.75	19.00	20.38	23.88	20	16	24	0.75	56
16	47.75	20.75	19.00	22.38	23.88	20	16	24	1.00	143T
18	48.75	21.75	19.00	25.38	27.88	20	16	24	1.00	145T
21	52.75	23.75	21.00	26.88	31.38	20	16	24	1.50	145T
24	53.75	24.75	21.00	28.88	35.38	20	16	24	3.00	184T
30	61.75	27.75	26.00	36.88	42.38	20	16	24	5.00	184T
36	65.75	30.75	27.00	42.88	48.38	20	16	20	10.00	215T
42	72.75	33.75	31.00	48.88	54.38	20	16	20	10.00	256T
48	79.75	36.75	35.00	54.88	60.38	20	14	20	10.00	256T

Dimensions are not to be used for construction.

D-4850-2B

**Belt Driven - THB/THBF**

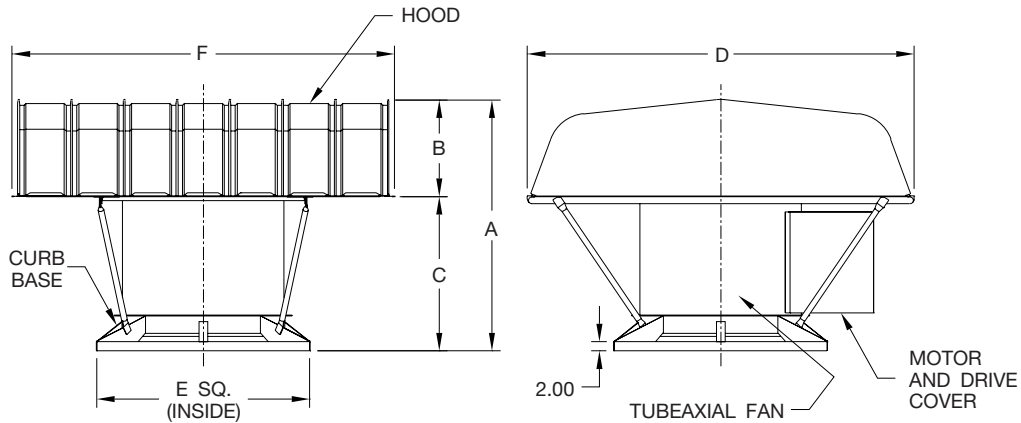

FAN SIZE	A MAX.		B		C		D		E		F		SHAFT SIZE	MAX. FRAME
	THB	THBF	THB	THBF	THB	THBF	THB	THBF	THB	THBF	THB	THBF		
14	38.75	—	11.75	—	27.00	—	40.00	—	23.88	—	39.00	—	0.75	56
16	38.75	—	11.75	—	27.00	—	40.00	—	23.88	—	39.00	—	0.75	143T
18	39.75	—	12.75	—	27.00	—	48.00	—	27.88	—	51.00	—	0.75	145T
21	44.38	44.75	15.75	16.13	28.63	28.62	54.00	54.00	31.38	31.38	51.00	51.00	0.75	145T
24	46.63	46.88	17.75	18.00	28.88	28.88	66.00	66.00	35.38	35.38	63.00	63.00	1.00	184T
30	53.88	54.13	19.75	20.00	34.13	34.13	75.00	78.00	42.38	42.38	75.00	87.00	1.00	213T
36	56.88	57.13	21.75	22.00	35.13	35.13	88.00	94.00	48.38	48.38	87.00	87.00	1.19	215T
42	62.88	63.13	23.75	24.00	39.13	39.13	86.00	93.00	54.38	54.38	99.00	99.00	1.44	215T
48	66.94	67.19	23.75	24.00	43.19	43.19	93.00	112.00	60.38	60.38	111.00	111.00	1.44	254T
54	71.94	72.19	23.75	24.00	48.19	48.19	112.00	124.00	74.38	74.38	111.00	123.00	1.44	256T
60	74.44	74.69	26.25	26.50	48.19	48.19	124.00	136.00	74.38	74.38	123.00	135.00	1.69	284T

Dimensions are not to be used for construction.

D-4850-3H  
D-4850-6E

**Direct Drive - THD/THDF**

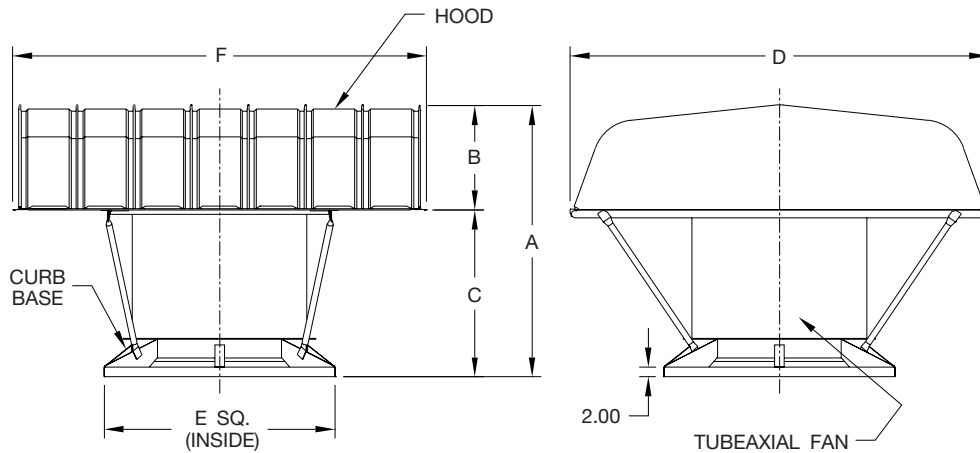

FAN SIZE	A MAX.		B		C		D		E		F		MAX. FRAME
	THD	THDF	THD	THDF	THD	THDF	THD	THDF	THD	THDF	THD	THDF	
14	40.13	—	13.13	—	27.00	—	48.00	—	23.88	—	51.00	—	56
16	40.13	—	13.13	—	27.00	—	48.00	—	23.88	—	51.00	—	143T
18	40.13	—	13.13	—	27.00	—	48.00	—	27.88	—	51.00	—	145T
21	44.75	44.75	16.13	16.13	28.62	28.62	54.00	54.00	31.38	31.38	51.00	51.00	145T
24	46.88	46.88	18.00	18.00	28.88	28.88	66.00	66.00	35.38	35.38	63.00	63.00	184T
30	54.13	54.13	20.00	20.00	34.13	34.13	75.00	78.00	42.38	42.38	75.00	87.00	184T
36	57.13	57.13	22.00	22.00	35.13	35.13	88.00	94.00	48.38	48.38	87.00	87.00	215T
42	63.13	63.13	24.00	24.00	39.13	39.13	86.00	93.00	54.38	54.38	99.00	99.00	256T
48	67.19	67.19	24.00	24.00	43.19	43.19	93.00	112.00	60.38	60.38	111.00	111.00	256T

Dimensions are not to be used for construction.

D-4850-4F  
D-4850-7D

## Accessories

### Roof Curb

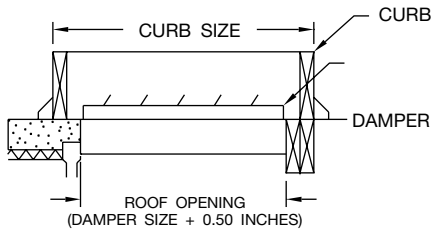

FAN SIZE	CURB DIMENSIONS
14	22.50 x 22.50
16	22.50 x 22.50
18	26.50 x 26.50
21	30 x 30
24	34 x 34
30	41 x 41
36	47 x 47
42	53 x 53
48	59 x 59
54	73 x 73
60	73 x 73

F-DMP-C

**Note:**

1. Curbs have 1/2" thick insulation, wood nailer (canted) or 3/16" polystyrene gasket (self-flashing) and damper tray as standard. A 12" high curb is required when using a motorized damper.

### Backdraft Damper

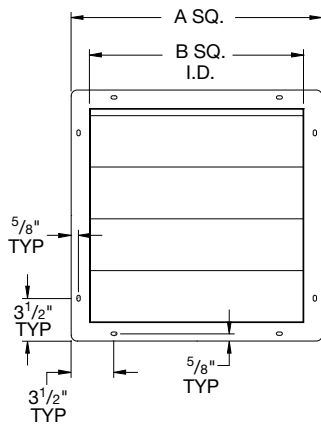

FAN SIZE	A SQ.	B SQ.	C	NO. OF PANELS
14	18.50	16	6	1
16	18.50	16	6	1
18	22.50	20	6	1
21	26	23.50	6	1
24	30	27.50	6	1
30	37	34.50	6	1
36	43	40.50	7.50	1
42	49	46.50	7.50	2
48	55	52.50	7.50	2
54	69	66.50	7.50	4
60	69	66.50	7.50	4

**Notes:**

1. Exhaust damper shown (with front flange).
2. Supply damper has rear flange.

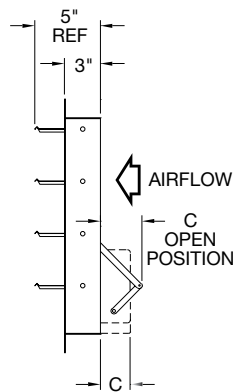



## Models

TUD | TUB | TUBSH

Upblast Tubeaxial Roof Ventilators shall be Model TUD (standard direct drive), Model TUB (standard belt driven), Model TUBSH (smoke and heat) as manufactured by Twin City Fan & Blower, Minneapolis, Minnesota.

**PERFORMANCE** — Performance ratings shall conform to AMCA Standard 211 (air performance) and 311 (sound performance). Fans shall be tested in accordance with ANSI/AMCA Standard 210 (air performance) and 300 (sound performance) in an AMCA accredited laboratory. Fans shall be licensed to bear the AMCA certified ratings seal for both sound and air, and fan energy index (FEI).

Models TUD and TUB shall be UL 705 listed. Model TUBSH shall be UL listed for Smoke Control Systems (500°F for 4 hours and 1000°F for 15 minutes). Fans shall bear a permanently attached nameplate displaying model and serial number of the unit for future identification.

**CONSTRUCTION** — Housings, curb caps and wind bands shall be constructed of heavy-gauge, continuously-welded steel to prevent air leakage. Motor and bearing supports shall be constructed of heavy-gauge steel and shall be suitably braced to prevent vibration or pulsation. Butterfly dampers shall contain a splash guard over the pivot area to protect against rain entry. Butterfly damper blades on models TUD and TUB shall be aluminum (sizes 14-36) and galvanized steel (sizes 42-60). Butterfly dampers on model TUBSH shall be galvanized steel as standard.

**IMPELLERS** — Impellers on model TUD shall be constructed of or cast aluminum blades and hubs. Impellers on model TUB shall be constructed of fabricated steel or cast aluminum blades and hubs. Impellers on model TUBSH shall be fabricated steel blades and hubs. Impellers shall be secured to the fan shaft with a taperlock bushing.

**SHAFTS (TUB and TUBSH Only)** — Shafts shall be AISI 1045 cold rolled steel, accurately turned, ground, polished and ring-gauged for accuracy. Shafts shall be sized for the first critical speed of at least 1.43 times the maximum speed.

**BEARINGS (TUB and TUBSH Only)** — Bearings are to be pillow block, heavy-duty, anti-friction, self-aligning, grease lubricated, ball type. Each fan's bearings are sized with a minimum average life, per AFBMA, in excess of 200,000 hours when operating at the maximum RPM of the fan size.

**DRIVES (TUB and TUBSH Only)** — Motor sheaves shall be cast iron and supplied as either variable pitch or fixed pitch. Drives and belts on model TUB shall be rated for a minimum of 150% of the required motor HP. Motor sheaves on model TUBSH shall be cast iron, fixed pitch as standard (variable pitch optional). Drives and belts on model TUBSH shall be rated for a minimum of 200% of the required motor HP and shall be two-groove minimum.

**MOTORS** — All motors shall be single phase or three phase induction, permanently lubricated, heavy-duty, ball bearing type, closely matched to the fan load and provided at the voltage, phase, hertz and enclosure as provided on the fan schedule. Direct drive motors shall be split phase and capacitor start.

**FINISH AND COATING** — The entire fan assembly, excluding the shaft, shall be properly washed and pretreated before application of a rust-preventative primer, if called out on the order. After the fan is completely assembled, a finish coat of paint shall be applied to the entire assembly, if called out on the order. The fan shaft shall be coated with a petroleum-based rust protectant. Aluminum components shall be unpainted.

**ACCESSORIES** — When specified, accessories such as fusible link assembly, magnetic damper latches, access door, shaft seal, spark resistant construction, roof curb and disconnect switch shall be provided by Twin City Fan to maintain one source responsibility.

**FACTORY RUN TEST** — All fans prior to shipment shall be completely assembled and test run as a unit at operating speed or maximum RPM allowed for the particular construction type. Each impeller shall be statically and dynamically balanced in accordance with ANSI/AMCA 204-96 "Balance Quality and Vibration Levels for Fans" to Fan Application Category BV-3, Balance Quality Grade G6.3. Balance readings shall be taken by electronic type equipment in the axial, vertical and horizontal directions on each of the bearings. Records shall be maintained and a written copy shall be available upon request.





## Models

THD | THB | THDF | THBF

Hooded Tubeaxial Roof Ventilators shall be Model THD (standard direct drive), Model THB (standard belt driven), Model THDF (filtered supply direct drive), Model THBF (filtered supply belt driven) as manufactured by Twin City Fan & Blower, Minneapolis, Minnesota.

**PERFORMANCE** — Performance ratings shall conform to AMCA Standard 211 (air performance) and 311 (sound performance). Fans shall be tested in accordance with ANSI/AMCA Standard 210 (air performance) and 300 (sound performance) in an AMCA accredited laboratory. Fans shall be licensed to bear the AMCA certified ratings seal for both sound and air, and fan energy index (FEI).

Models THD, THB, THDF, THBF shall be UL 705 listed. Fans shall bear a permanently attached nameplate displaying model and serial number of the unit for future identification.

**CONSTRUCTION** — Housings shall be constructed of heavy-gauge, continuously-welded steel to prevent air leakage. Motor and bearing supports shall be constructed of heavy-gauge steel and shall be suitably braced to prevent vibration or pulsation. Hoods shall be constructed of heavy-gauge galvanized steel.

**IMPELLERS** — Impellers shall be constructed of fabricated steel or cast aluminum blades and hubs. Impellers shall be secured to the fan shaft with a taperlock bushing.

**SHAFTS (THB and THBF Only)** — Shafts shall be AISI 1045 cold rolled steel, accurately turned, ground, polished and ring-gauged for accuracy. Shafts shall be sized for the first critical speed of at least 1.43 times the maximum speed.

**BEARINGS (THB and THBF Only)** — Bearings are to be pillow block, heavy-duty, anti-friction, self-aligning, grease lubricated, ball type. Each fan's bearings are sized with a minimum average life, per AFBMA, in excess of 200,000 hours when operating at the maximum RPM of the fan size.

**DRIVES (THB and THBF Only)** — Motor sheaves shall be cast iron and supplied as either variable pitch or fixed pitch. Drives and belts shall be rated for a minimum of 150% of the required motor HP.

**MOTORS** — All motors shall be single phase or three phase induction, permanently lubricated, heavy-duty, ball bearing type, closely matched to the fan load and provided at the voltage, phase, hertz and enclosure as provided on the fan schedule. Direct drive motors shall be split phase and capacitor start.

**FINISH AND COATING** — The entire fan assembly, excluding the shaft, shall be properly washed and pretreated before application of a rust-preventative primer, if called out on the order. After the fan is completely assembled, a finish coat of paint shall be applied to the entire assembly, if called out on the order. The fan shaft shall be coated with a petroleum-based rust protectant. Aluminum components shall be unpainted. Hoods shall be galvanized steel.

**ACCESSORIES** — When specified, accessories such access door, shaft seal, backdraft and motorized dampers, spark resistant construction, curb extension, roof curb and disconnect switch shall be provided by Twin City Fan to maintain one source responsibility.

**FACTORY RUN TEST** — All fans prior to shipment shall be completely assembled and test run as a unit at operating speed or maximum RPM allowed for the particular construction type. Each impeller shall be statically and dynamically balanced in accordance with ANSI/AMCA 204-96 "Balance Quality and Vibration Levels for Fans" to Fan Application Category BV-3, Balance Quality Grade G6.3. Balance readings shall be taken by electronic type equipment in the axial, vertical and horizontal directions on each of the bearings. Records shall be maintained and a written copy shall be available upon request.

# INDUSTRIAL PROCESS AND COMMERCIAL VENTILATION SYSTEMS

CENTRIFUGAL FANS | UTILITY SETS | PLENUM & PLUG FANS | INLINE CENTRIFUGAL FANS  
MIXED FLOW FANS | TUBEAXIAL & VANEAXIAL FANS | WALL MOUNTED FANS | ROOF VENTILATORS  
CENTRIFUGAL ROOF & WALL EXHAUSTERS | CEILING VENTILATORS | GRAVITY VENTILATORS | DUCT BLOWERS  
RADIAL BLADED FANS | RADIAL TIP FANS | HIGH EFFICIENCY INDUSTRIAL FANS | PRESSURE BLOWERS  
LABORATORY EXHAUST FANS | FILTERED SUPPLY FANS | MANCOOLERS | FIBERGLASS FANS | CUSTOM FANS



**TWIN CITY FAN & BLOWER**  
**[WWW.TCF.COM](http://WWW.TCF.COM)**

5959 TRENTON LANE N. | MINNEAPOLIS, MN 55442 | PHONE: 763-551-7600 | FAX: 763-551-7601

©2002-2023 Twin City Fan Companies, Ltd., Minneapolis, MN. All rights reserved. Catalog illustrations cover the general appearance of Twin City Fan & Blower products at the time of publication and we reserve the right to make changes in design and construction at any time without notice.