



KRUGER

BDB

DOUBLE INLET
CENTRIFUGAL FAN
with Backward Wheels



BDB Series

DOUBLE INLET CENTRIFUGAL FAN with Backward Wheels



Kruger* certifies that the **BDB series** shown herein is licensed to bear the AMCA Seal. The ratings shown are based on tests and procedures performed in accordance with AMCA publication 211 and AMCA publication 311 and comply with the requirements of the AMCA Certified Ratings Program.

- *Kruger Ventilation Industries Asia Co, Ltd
- *Kruger Ventilation Industries (Thailand) Co. Ltd.
- *Kruger Ventilation Industries (Taiwan) Co. Ltd.
- *Kruger Ventilation Industries (North India) Pvt. Ltd.
- *Kruger Ventilation Industries (India) Pvt. Ltd.
- *Kruger Ventilation Industries (Vietnam) Co. Ltd.
- *Kruger M&E Industries Corporation
- *Guangzhou Kruger Ventilation Co. Ltd.
- *Shanghai Kruger Ventilation Co. Ltd.
- *Tianjin Kruger Ventilation Co. Ltd.
- *Wuhan Kruger Ventilation Co. Ltd.
- *Kruvent Industries (M) Sdn Bhd
- *PT Kruger Ventilation Indonesia



BDB Series

Double Inlet Centrifugal Fans – Backward wheels

The BDB series is DIDW centrifugal fans with high efficiency non-overloading backward curved impellers. The fans are suitable for supply or extract applications in commercial, process and industrial HVAC systems. Sizes of this series are in accordance with AMCA standard 99-0098-76 R20.

BDB Series – Direct Coupling

Product Description

- Centrifugal fans BDB series, double inlet, direct drive through coupling with built-on motor.
- Designed in accordance with AMCA Drive Arrangement 7 or ISO Drive Arrangement 17.
- High energy saving particularly long operating hours with Kruger’s Ecowatt system (Control, Motor and Drive)
- Fan and drive unit attached to a common rigid and stable base frame.
- Full range of BDB 315mm to 1400mm wheel.
- Carbon steel fan as standard with options for stainless steel material.
- Maintenance and wear free drive (no V-belts)
- Optimal aerodynamics due to the large free cross section and minimal flow restriction into the impeller.
- Reliable, flexible and adaptable flex coupling for trouble free operation and installation.
- Speed control with Kruger inverter drive with open loop and close loop controls available.
- Fully assembled fan trim balanced to ISO 14694:2003 & AMCA 204, G2.5 Standard. G1.0 Standard is available upon request.
- Not available on twin wheel.

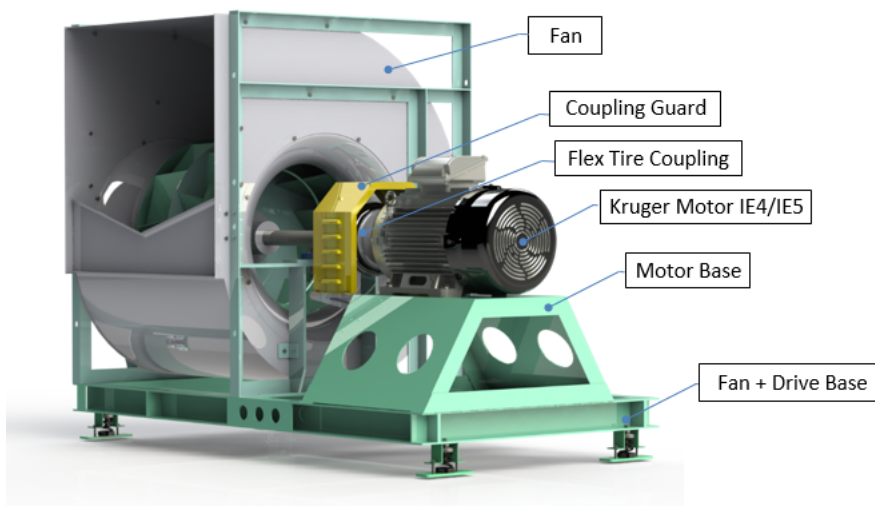

Ecowatt Pressure/Airflow Control (TDP-PI)



Ecowatt Speed Control (REB-ECOWATT)



Ecowatt Variable Frequency Drive (K354 Series)

Nomenclature

MODEL: BDB 450 C M D

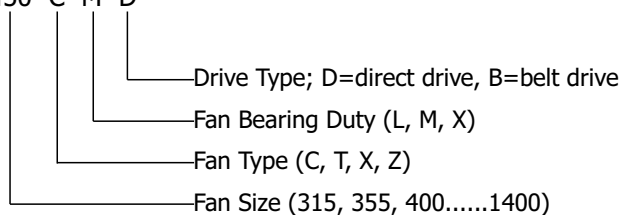

Model 315 to 710		
Type S-C	I	Model 800 to 1400
Type T	II	I
Type X	III	II
Type Z		III

Table 1

Type / Operating Limit

Each fan type has its maximum operating speed and power due to its mechanical design.

The operating limit of BDB series - fan type is design to meet the requirement of class I, II and III limit as defined in AMCA standard 99-2408-69.

The BDB series is available in type S, C, T, X or Z.

Model 315-710		Model 400-710		Model 800-1400	
Type C	I				
Type T		II	Model 500-710	I	
Type X			III	II	
Type Z				III	

Table 2

Table 1 is the available classes for bare fan
Table 2 is the available classes for direct coupling fan

To include drawing of type C/T/X with direct coupling to the below

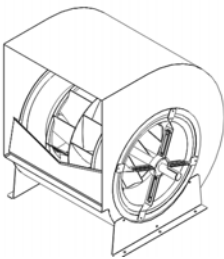

Type S

This type is supplied with mounting feet and can be mounted in three different orientations. The construction is mainly for OEM application which only subject to testing and approval.

Fan Size : 315 to 710
Volume : 1900 to 50000 m3/h
Total Pressure : up to 2000 Pa

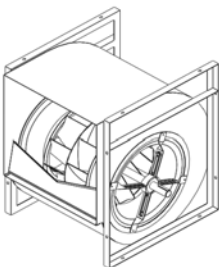

Type C

This type has a frame fitted on both sides of the fan which gives better strength and rigidity. It allows mounting in four different orientations.

Fan Size : 315 to 710
Volume : 1900 to 50000 m3/h
Total Pressure : up to 2000 Pa

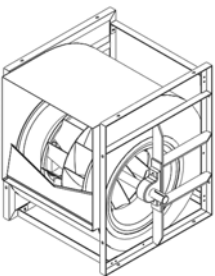
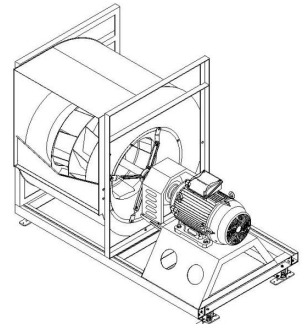

Type T

This type has a welded frame giving increased stiffness and rigidity required for higher operating performance.

Fan Size : 315 to 1400
Volume : 1900 to 190 000 m3/h
Total Pressure : up to 2500 Pa

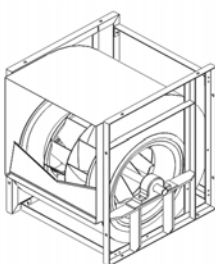
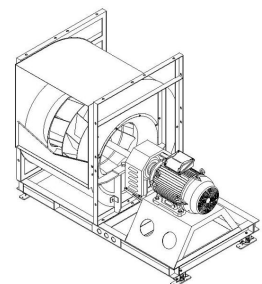

Type X/Z

The structure is similar to type T but utilizes enhanced bearings to support higher dynamic load necessary for the increased performance.

Fan Size : 315 to 1400
Volume : 1900 to 260 000 m3/h
Total Pressure : up to 3200 Pa

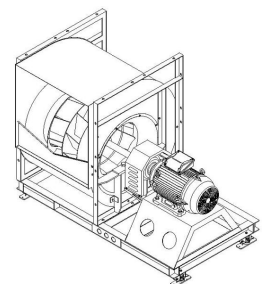

Type Z is non-standard, for more information, please consult your nearest Kruger Office for details.

Kruger Ecowatt Motor

- Reliable Induction Motor with Energy efficiency classes IE1/IE2/IE3
- Premium Efficiency Permanent Magnet Motor IE4/IE5 are available upon request
- Design Standards BS 4999, BS 5000, IEC 60034, IEC 60072
- Rated voltage 380-415 Hz/50Hz \pm 10%
- Stator Insulation; Class F Insulation; Class B Temperature Rise
- Horizontal foot mounting or flange mounting: B3; B5, B14, B34; B35; V1
- Standard Ambient Temperature: -20°C to 40°C; RH: <90% RH (non-condensation); Altitude < 1000m above sea level.



Kruger Ecowatt Drive

- High Performance Inverter Drive with advanced vector control technology
- Energy saving by PID function for Demand Controlled Ventilation.
- Easy control by Analog signal 0-10V, 4-20mA and RS485 Modbus RTU.
- Various drives both AC induction motor and permanent magnet synchronous motor.
- IP54 protection rating, independent duct design (IP20) also available.
- Safety by STO (safe Torque Off) and fire overdrive function.
- Wide range of output power 2.2kW – 220kW.



Kruger Ecowatt Demand Controlled Ventilation

- Automatic close loop PID control by TDP-PI Ventilation controller
 - Constant Airflow control
 - Constant Differential pressure control

Controller will maintain Pressure or Airflow as setting value by change fan speed up-down automatically follow actual load demand.

- Manual speed control by REB-Ecowatt
 - Adjust Fan speed by your hand with potentiometer 10kohm



Flex Couplings

- High quality standard SKF flex couplings are used.
- Designed to accommodate misalignment and shock loads and damper vibration levels.
- Easy to install and maintenance free.
- Natural rubber compounds for application ranging from -50°C to +50°C.
- Couplings selection based on service factor as recommended by manufacturer.
- Other types of coupling are available upon request and approval by factory.

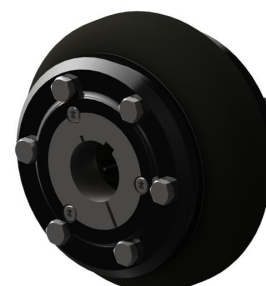

Why Choose an Ecowatt Direct Coupling System?

- Highly efficient backward curved with FEG rating from 85-90 with direct coupling reduces frictional losses and optimizes transmission and improves energy costs.
- The energy that the electric motor generates is transmitted directly to the impeller, which passes into airflow and pressure development increases the overall fan system efficiency.
- In addition, zero belt wears and break on belt improves reliability and productive run time and unnecessary maintenance.
- Save energy cost up to 78% when driven by Kruger Ecowatt system

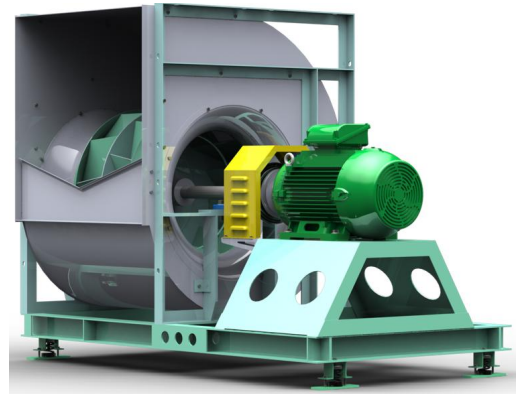

Typical applications:

- Air handling unit installations in commercial or industrial settings where a low energy input is required.
- Air handling unit installations for industrial or food manufacturing clean rooms where unwanted belt residue is completely removed and with an easier to clean fan.
- Air handling unit installations where conventional belt driven high energy input system is to be refurbished.

BDB Twin Fan

BDB series are also available in twin fan version, with two double inlet fans mounted on the same shaft. To select for twin fans, use the curves of single fan with the following factors: -

Volume	x 2
Absorbed Power	x 2.15
Speed	x 1.05
Noise	+ 3 dB

This series is available in type S2, C2 or T2

Performance of Twin fans are not AMCA licensed

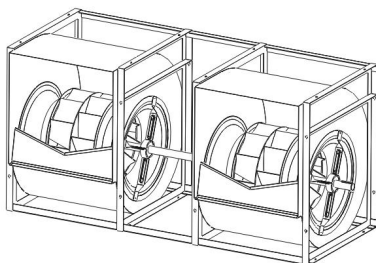

Type S2
Size: 315 to 500
5000 to 50000m³/h

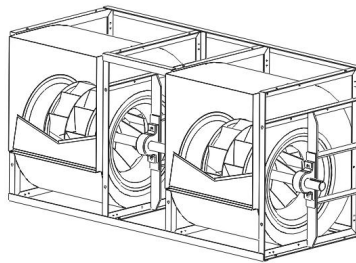

Type C2
Size: 315 to 500
5000 to 50000m³/h

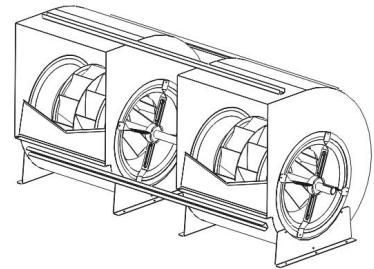

Type T2
Size: 355 to 630
10000 to 80000m³/h

TECHNICAL SPECIFICATION

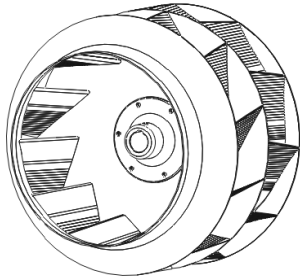

Wheel

The wheel of BDB series is made of cold rolled sheet steel backward curved blades with polyester powder coating finish. Alternative material of construction in stainless steel and aluminium are also available upon request.

Housing

For all sizes except 1250 and above, the housing is manufactured in galvanized sheet steel with the housing fixed to the side plates in "pittsburg lock" form system.

Housings for 1250 and 1400 are manufactured in mild steel finished with polyester powder coating.

Fully welded housings are available upon request.

Frame

The frame is manufactured with galvanized angular bars for type "C". For type "T" and "X", they are manufactured with sections of steel and finished with polyester powder coating.

Shaft

Shafts are manufactured from C45 carbon steel using an automatic process for positioning and cutting of the keyways. All dimensional tolerances of the shaft are fully checked to ensure a precision fit and then coated with an anti-corrosion varnish after assembly.

Bearings

Bearings used are either deep groove ball bearing type with an adaptor sleeve or spherical roller bearings type sealed at both sides for different duty application classified as below:

		Mounted in a rubber housing		Mounted on cast iron supports with grease point	
Fan Type	S	C	T	X	
Bearing Duty	SM Medium Duty	CM Medium Duty	TM Medium Duty	XM Medium Duty	
eg. Model: BDB 450		C M	TX Extra Heavy	XX Extra Heavy	
		<ul style="list-style-type: none"> — Fan Bearing Duty (L, M, X) — Fan Type (S, C, T, X, Z) — Fan Size (315, 355, 400...1400) 			

The bearings are lubricated for life and maintenance-free. If re-lubrication is necessary, it is recommended to use a lithium base grease suitable for all temperatures within the limits of operation.

Balancing Quality

All wheels are statically and dynamically balanced to ISO1940 and AMCA 204 – G2.5 standard.

All fans after assembly are trim-balanced to ISO1940 and AMCA 204 - G2.5 standard.

Clean room application fans with balancing grade of G1.0 are available upon request.

ACCESSORIES

Casing Drain

This option is available when fans are exposed to the atmosphere or operating in high humidity condition.

Outlet Flanges

Outlet flanges are available upon request.

Inspection Doors

The inspection door can be supplied upon request. It can be supplied in one of the three positions (P3, P4 & P5).

Guards

Inlet guards, discharge guards and non-drive end shaft guards are available on request.

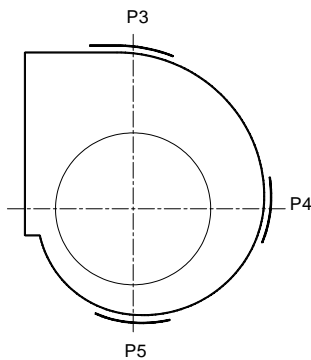

Fan Rotation and Discharge

The rotation and discharge of the fan is in accordance with AMCA standard 99-2406-83. The direction of rotation is determined from the drive side of the fan:

CW - clockwise rotation

CCW - counter-clockwise rotation

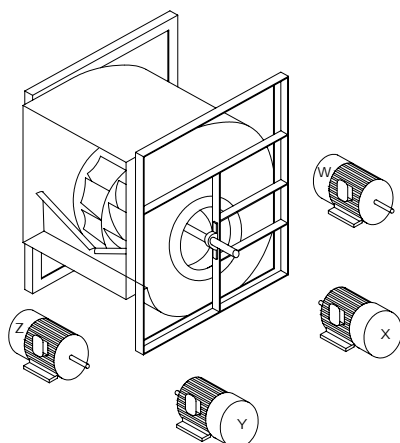
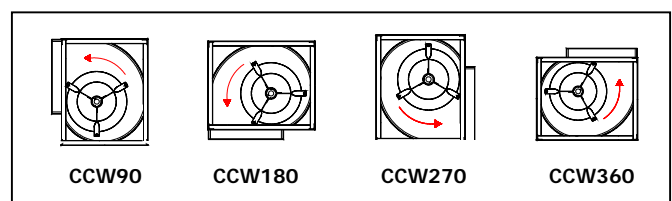
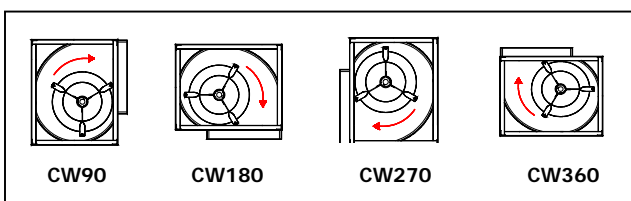

Motor Position

The position of the motor for belt drive centrifugal fan is in accordance with AMCA standard 99-2407-66.

Location of motor is determined by facing the drive side of fan and designated by letters W, X, Y, or Z.

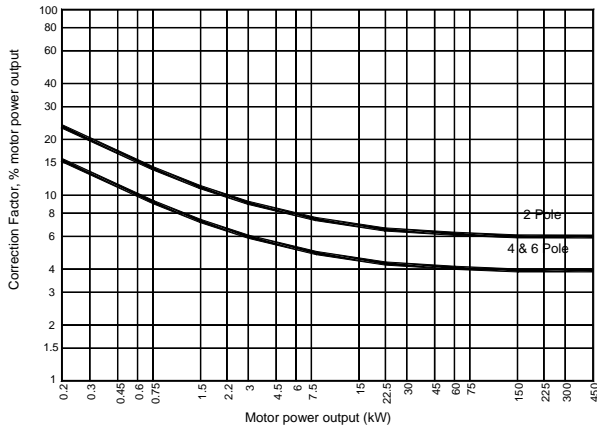

Motor Selection

The power curves shown on each performance graph represent the absorbed power at the shaft of the fan measured in kW.

To determine the power of the motor to be installed, a correction factor should be applied to compensate for transmission losses.

For conversion to horsepower (HP), use multiplying factor 1.34.

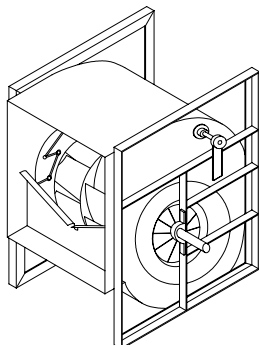

Inlet Vane Control

The inlet vane control enables energy saving that varies according to the vane control methods compared to traditional volume control methods.

Fig.1 shows the volume reduction corresponding to the vane position.

- with vane fully open (Pos 90°) the volume will be 3% less than the catalogue performance.
- with vane fully closed (Pos 0°) the volume will be reduced by 75%.

Performance of Inlet vane control is not AMCA licensed.

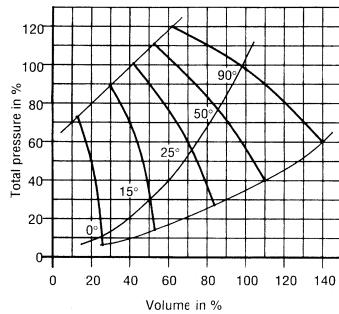

Fig. 1

IVC orientation and accessories

The standard orientation and lever position for the IVC is indicated in Fig.2. When ordering a complete fan with IVC and accessories, please specify as follow:

Fan orientation e.g. CCW270
lever position e.g. Pos. 45°

Example : Fan Model – CCW270/P45

Orientation	90	180	270	360
	225°	315°	45°	135°
IVC Level Position				
	315°	45°	135°	225°

Fig. 2 - IVC Orientation and Level Position

Dynamic Pressure

Both dynamic pressure and outlet air velocity values shown on each graph are calculated base on the full discharge area, i.e. ducted outlet condition.

With free outlet condition the velocity pressure is higher. To determine this new value multiply the velocity pressure of the ducted outlet obtained from the fan curve by the following correction factor "K".

$$K = 1.67$$

Fan performance calculated with this correction factor is not licensed by AMCA.

Performance

The performance data shown on each graph is derived from tests conducted in accordance to AMCA Standard 210 – Fig 12 – installation type B (free inlet and ducted outlet condition).

Ratings refer to the standard air density with the total pressure as a function of the air volume, using logarithmic scale.

It is essential that the same installation type and test standards are used at all times when comparing fan performance.

Noise

The noise levels shown on each graph refer to the "A-weighted" sound power values and the data on the inlet side has been measured in accordance with AMCA Standard 300 diag. 2 - configuration "B". The noise levels of fans are determined as follow :

- Sound power level - ("A" scale): $L_w(A)$ as catalogue
- Octave band spectrum: $L_w = L_w(A) + L_w \text{ rel. dB}$ [refer to Kruger for more details]
- Sound pressure level:
 - a) free field
 $= L_w(A) - (20\log_{10}d) - 11$
 - b) room conditions
 $= L_w(A) - (20\log_{10}d) - 8$where d = distance from fan (m)

Example of Selection

- Air Volume $Q = 14760 \text{ m}^3/\text{h}$
- Outlet Velocity $V = 10.07 \text{ m/s}$
- Dynamic Pressure $P_d = 62 \text{ Pa}$
- Total Pressure $P_t = 1515 \text{ Pa}$
- Fan Speed $N = 1900 \text{ rpm}$
- Absorbed Power $W = 8 \text{ kW}$
- Total Efficiency $\eta = 78 \%$
- Sound Power Level $L_w(A) = 90.3 \text{ dB(A)}$

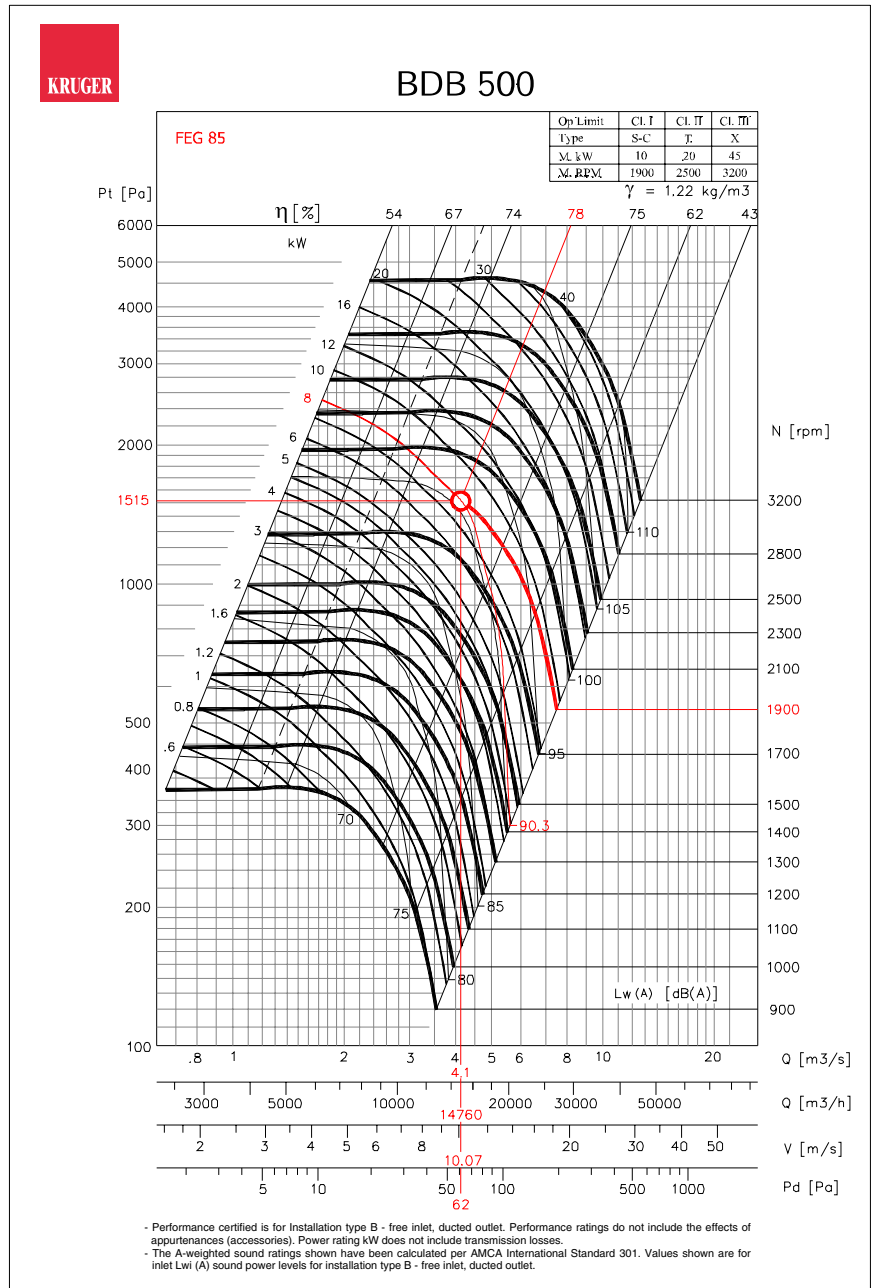



BDB 315

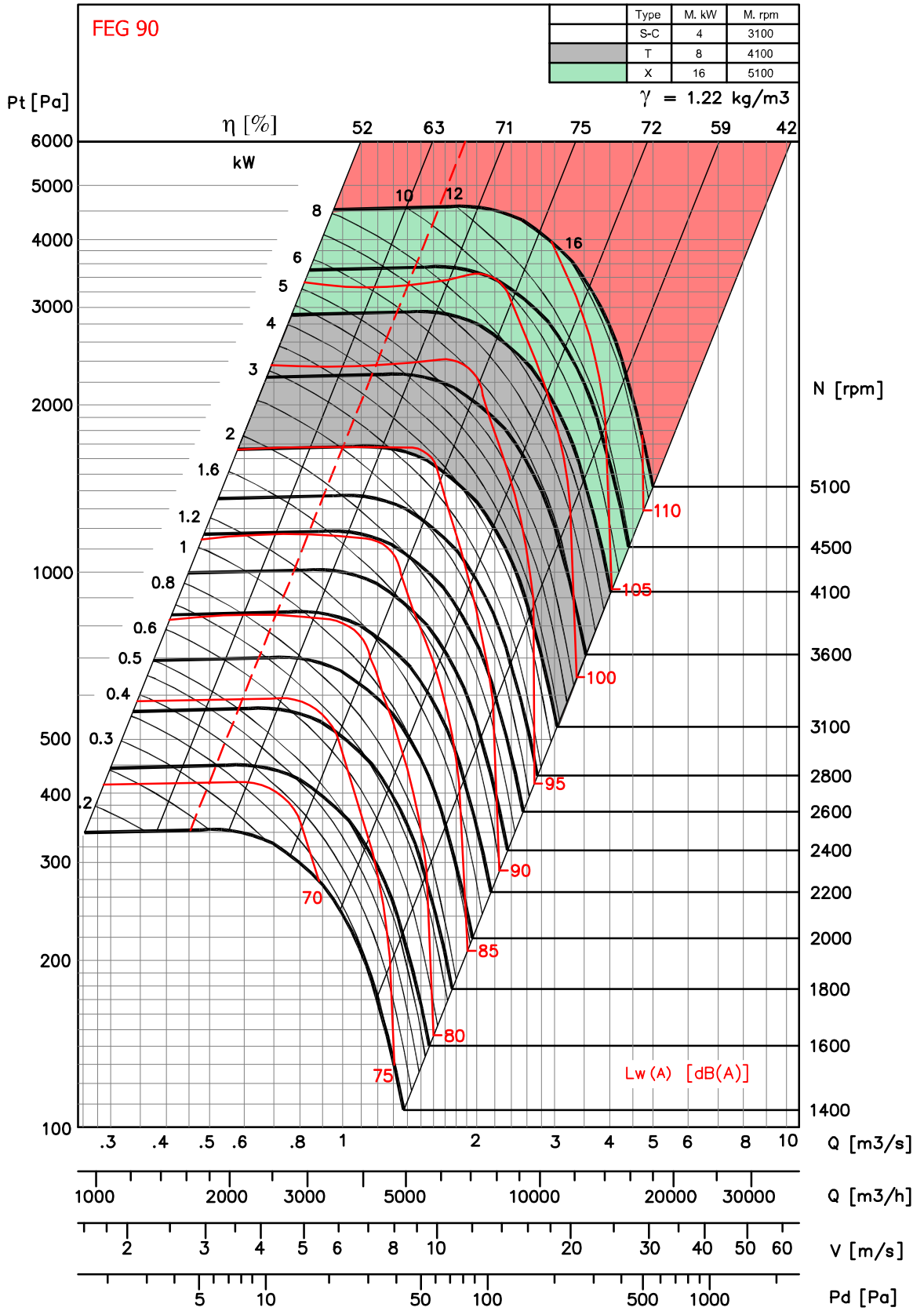

- Performance certified is for Installation type B - free inlet, ducted outlet. Performance ratings do not include the effects of appurtenances (accessories). Power rating kW does not include transmission losses.
 - The A-weighted sound ratings shown have been calculated per AMCA International Standard 301. Values shown are for inlet $L_{wi}(A)$ sound power levels for installation type B - free inlet, ducted outlet.



BDB 355

FEG 85

Type	M. kW	M. rpm
S-C	5	2700
T	11	3500
X	22	4500

$\gamma = 1.22 \text{ kg/m}^3$

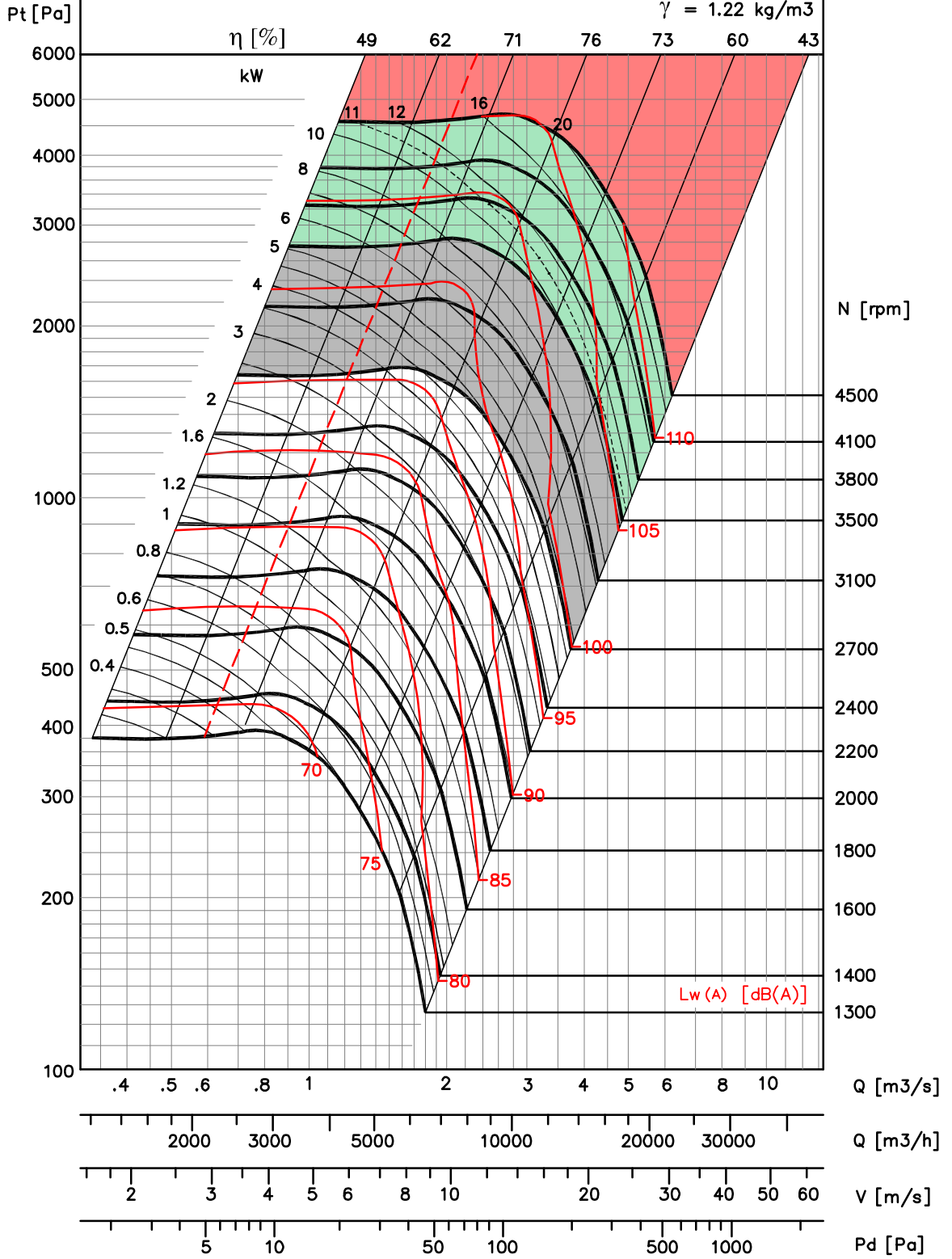

- Performance certified is for Installation type B - free inlet, ducted outlet. Performance ratings do not include the effects of appurtenances (accessories). Power rating kW does not include transmission losses.
 - The A-weighted sound ratings shown have been calculated per AMCA International Standard 301. Values shown are for inlet Lwi (A) sound power levels for installation type B - free inlet, ducted outlet.



BDB 400

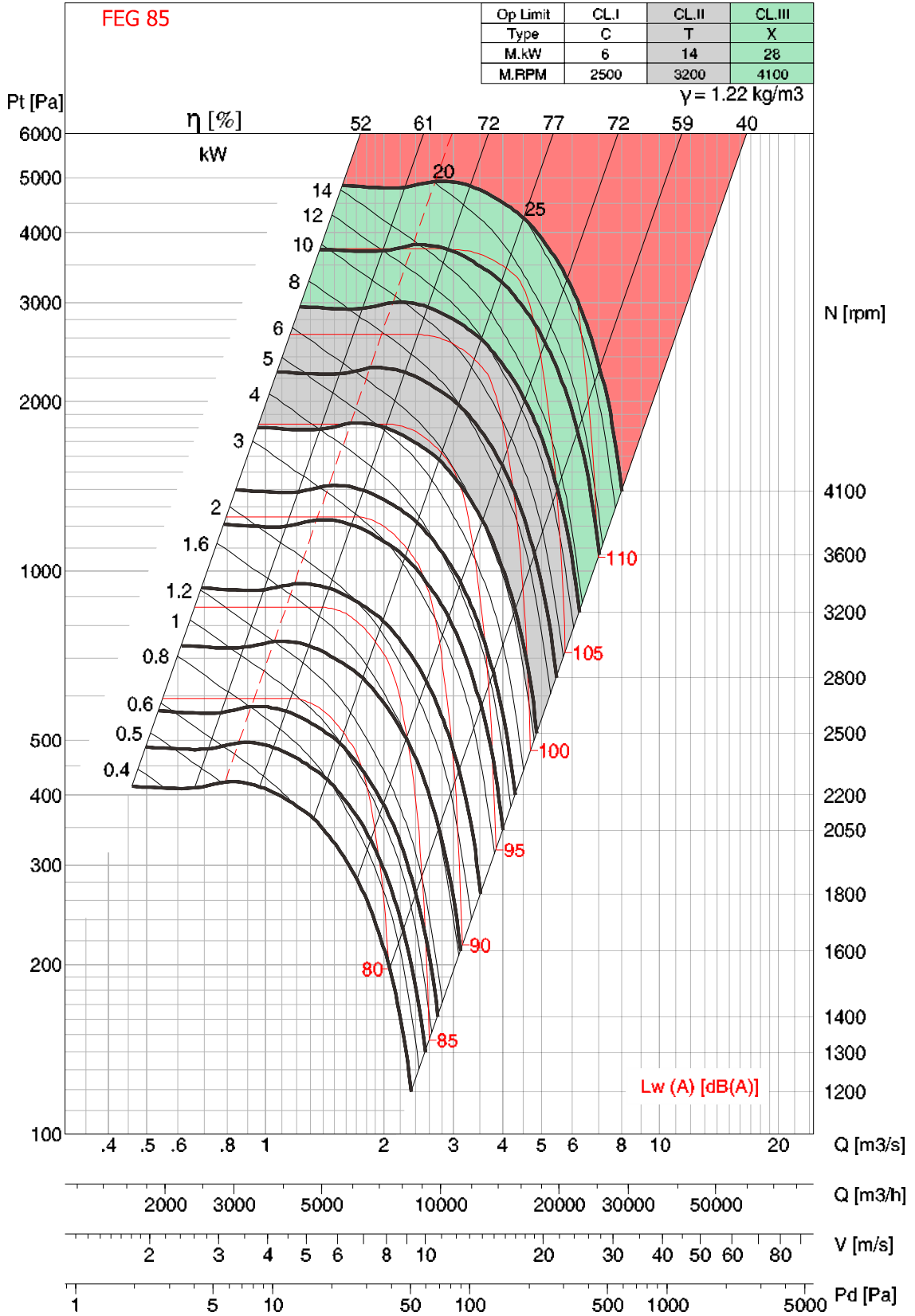

- Performance certified is for Installation type B - free inlet, ducted outlet. Performance ratings do not include the effects of appurtenances (accessories). Power rating kW does not include transmission losses.
 - The A-weighted sound ratings shown have been calculated per AMCA International Standard 301. Values shown are for inlet L_{wi} (A) sound power levels for installation type B - free inlet, ducted outlet.



BDB 450

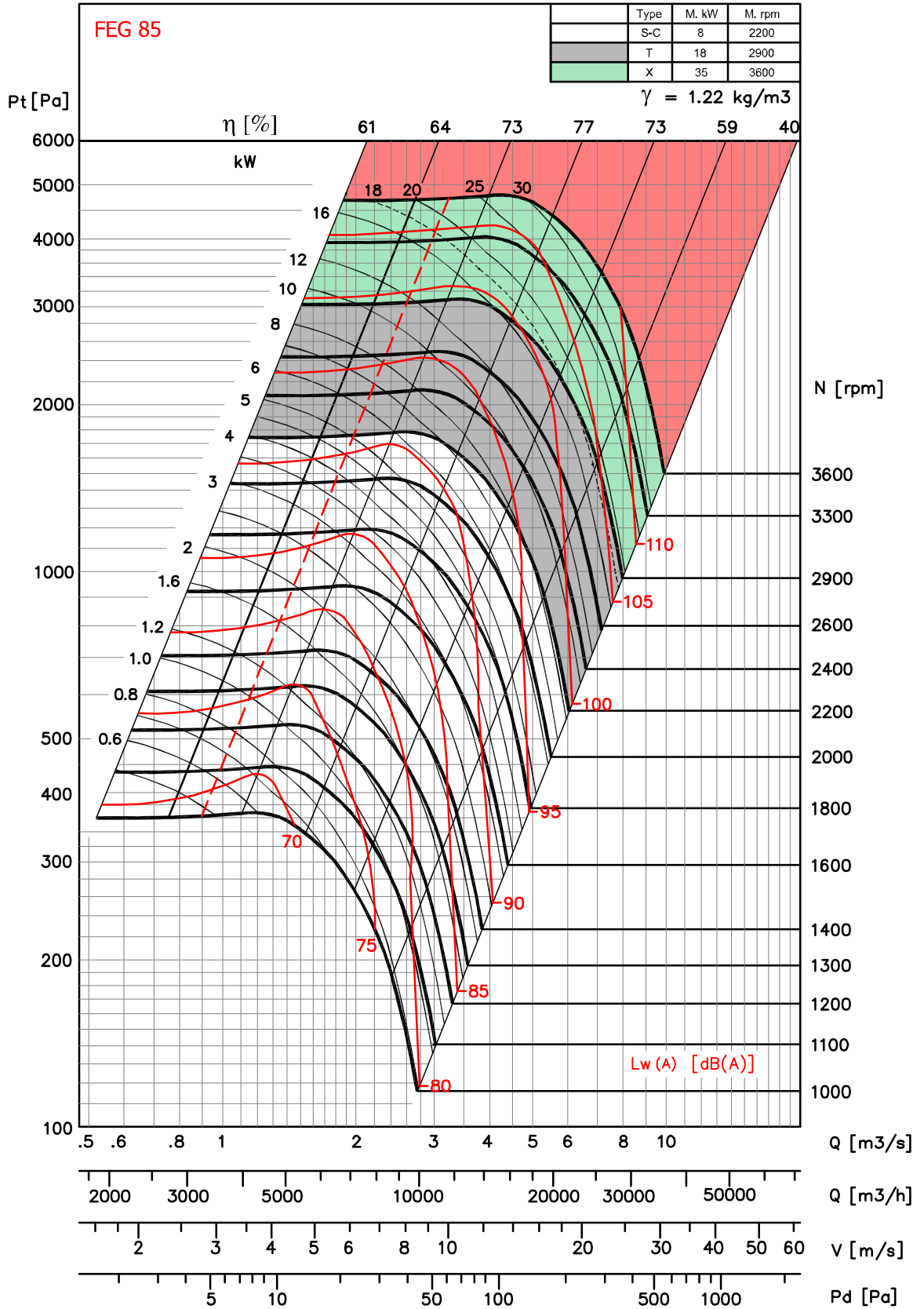

- Performance certified is for Installation type B - free inlet, ducted outlet. Performance ratings do not include the effects of appurtenances (accessories). Power rating kW does not include transmission losses.
 - The A-weighted sound ratings shown have been calculated per AMCA International Standard 301. Values shown are for inlet Lwi (A) sound power levels for installation type B - free inlet, ducted outlet.



BDB 500

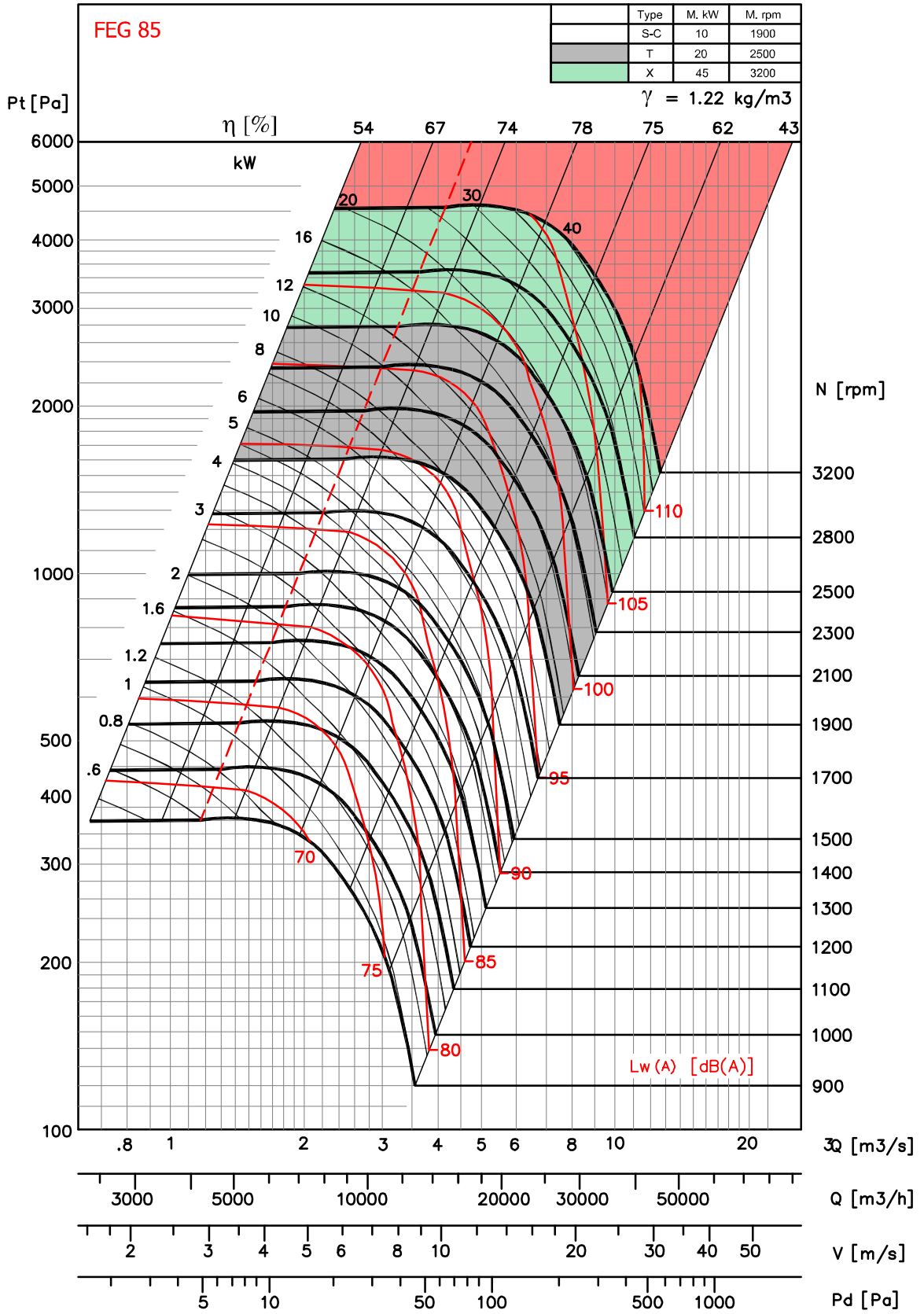

- Performance certified is for Installation type B - free inlet, ducted outlet. Performance ratings do not include the effects of appurtenances (accessories). Power rating kW does not include transmission losses.
 - The A-weighted sound ratings shown have been calculated per AMCA International Standard 301. Values shown are for inlet Lwi (A) sound power levels for installation type B - free inlet, ducted outlet.



BDB 560

FEG 85

Type	M. kW	M. rpm
S-C	12	1700
T	25	2200
X	50	2800

$\gamma = 1.22 \text{ kg/m}^3$

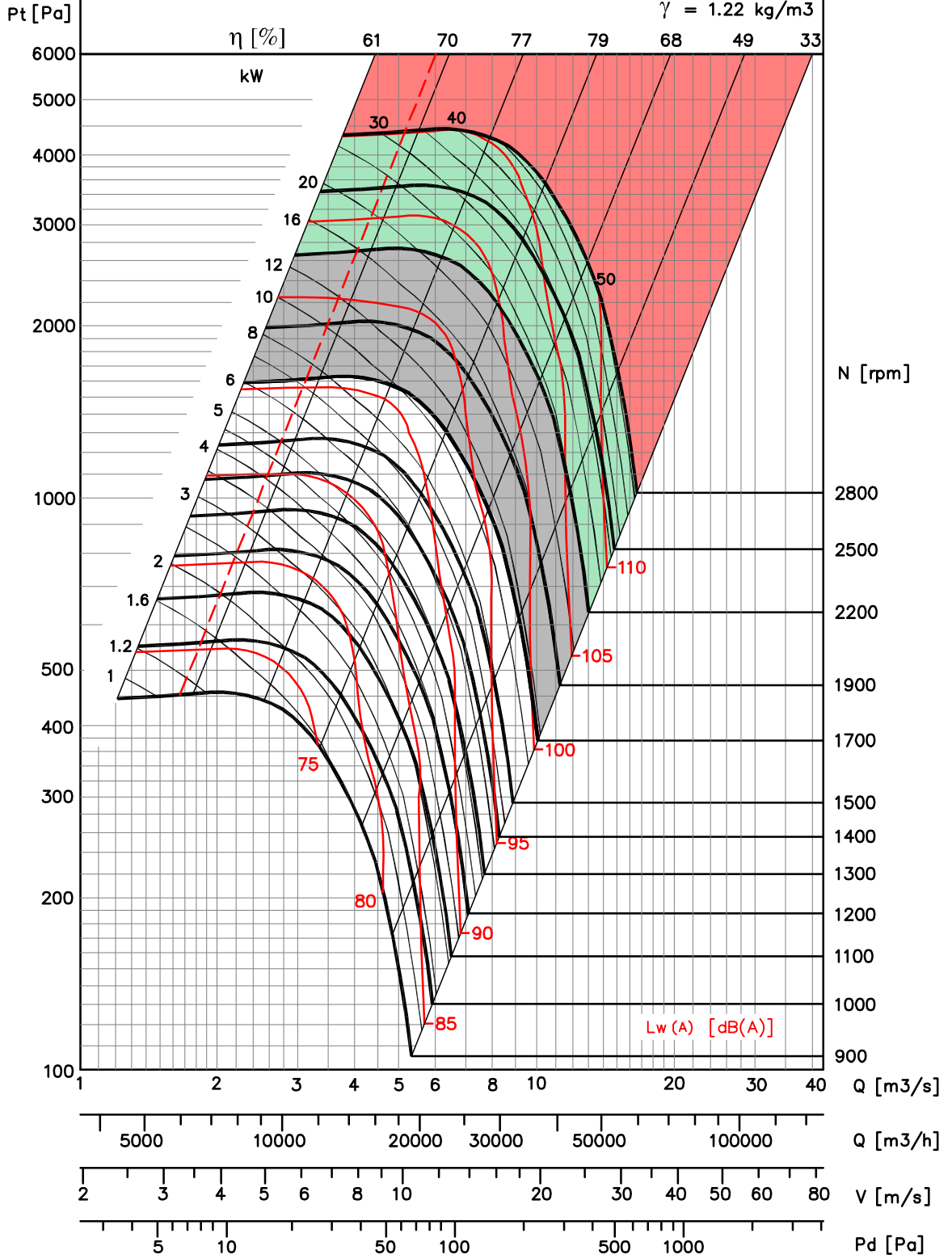

- Performance certified is for Installation type B - free inlet, ducted outlet. Performance ratings do not include the effects of appurtenances (accessories). Power rating kW does not include transmission losses.
- The A-weighted sound ratings shown have been calculated per AMCA International Standard 301. Values shown are for inlet Lwi (A) sound power levels for installation type B - free inlet, ducted outlet.



BDB 630

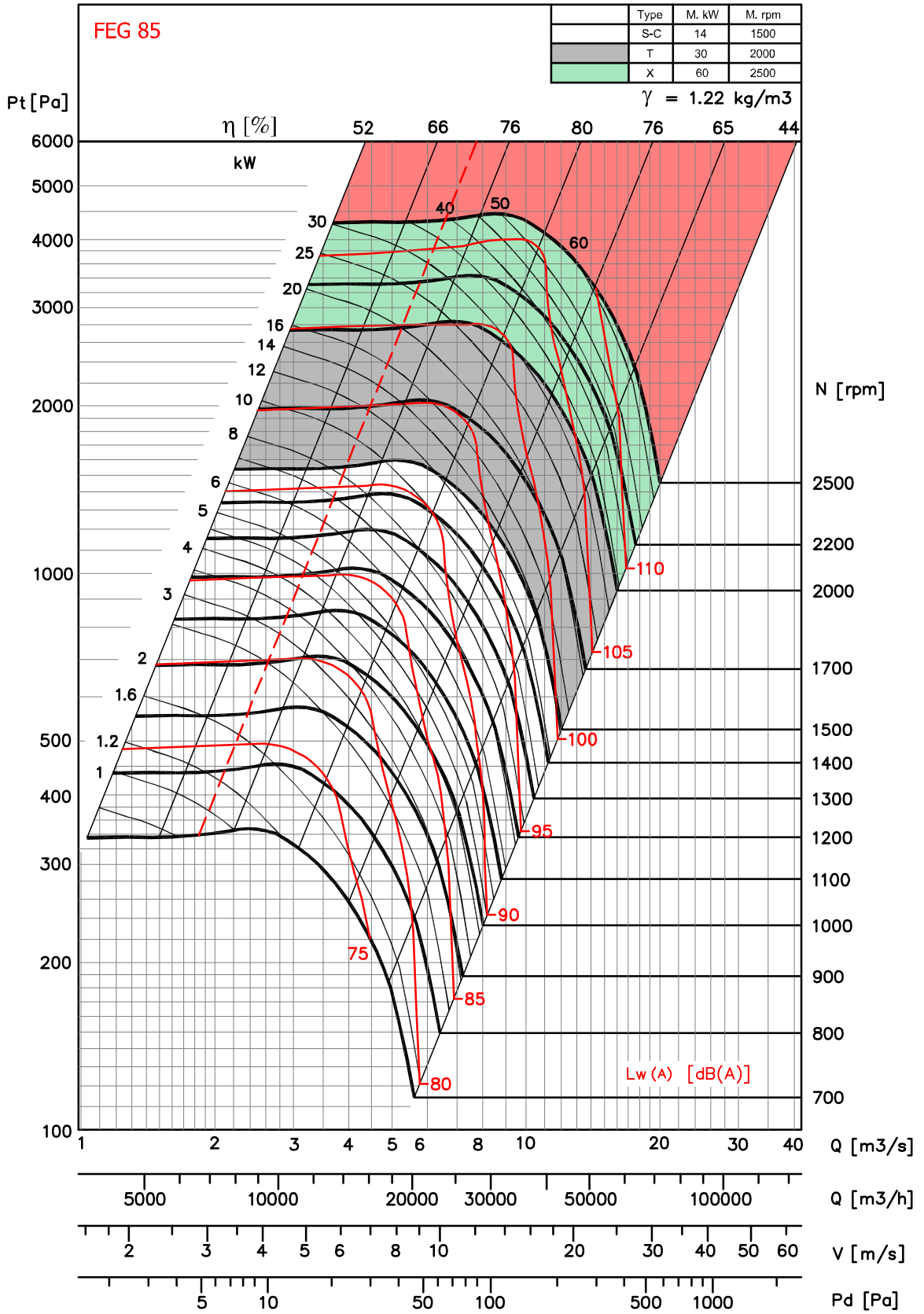

- Performance certified is for Installation type B - free inlet, ducted outlet. Performance ratings do not include the effects of appurtenances (accessories). Power rating kW does not include transmission losses.
 - The A-weighted sound ratings shown have been calculated per AMCA International Standard 301. Values shown are for inlet Lwi (A) sound power levels for installation type B - free inlet, ducted outlet.



BDB 710

FEG 85

Type	M. kW	M. rpm
S-C	18	1350
T	40	1800
X	80	2200

$\gamma = 1.22 \text{ kg/m}^3$

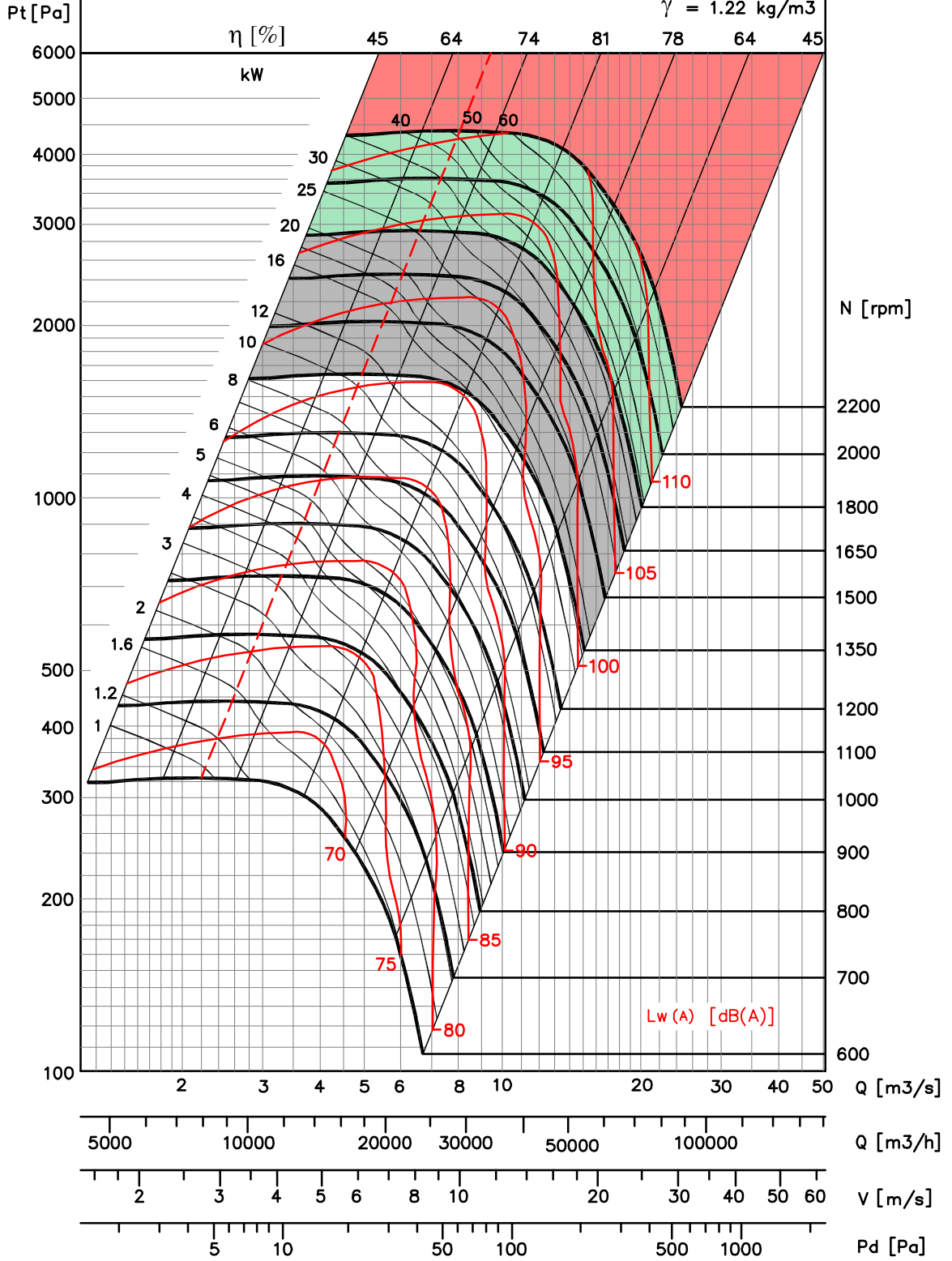

- Performance certified is for Installation type B - free inlet, ducted outlet. Performance ratings do not include the effects of appurtenances (accessories). Power rating kW does not include transmission losses.
- The A-weighted sound ratings shown have been calculated per AMCA International Standard 301. Values shown are for inlet Lwi (A) sound power levels for installation type B - free inlet, ducted outlet.



BDB 800

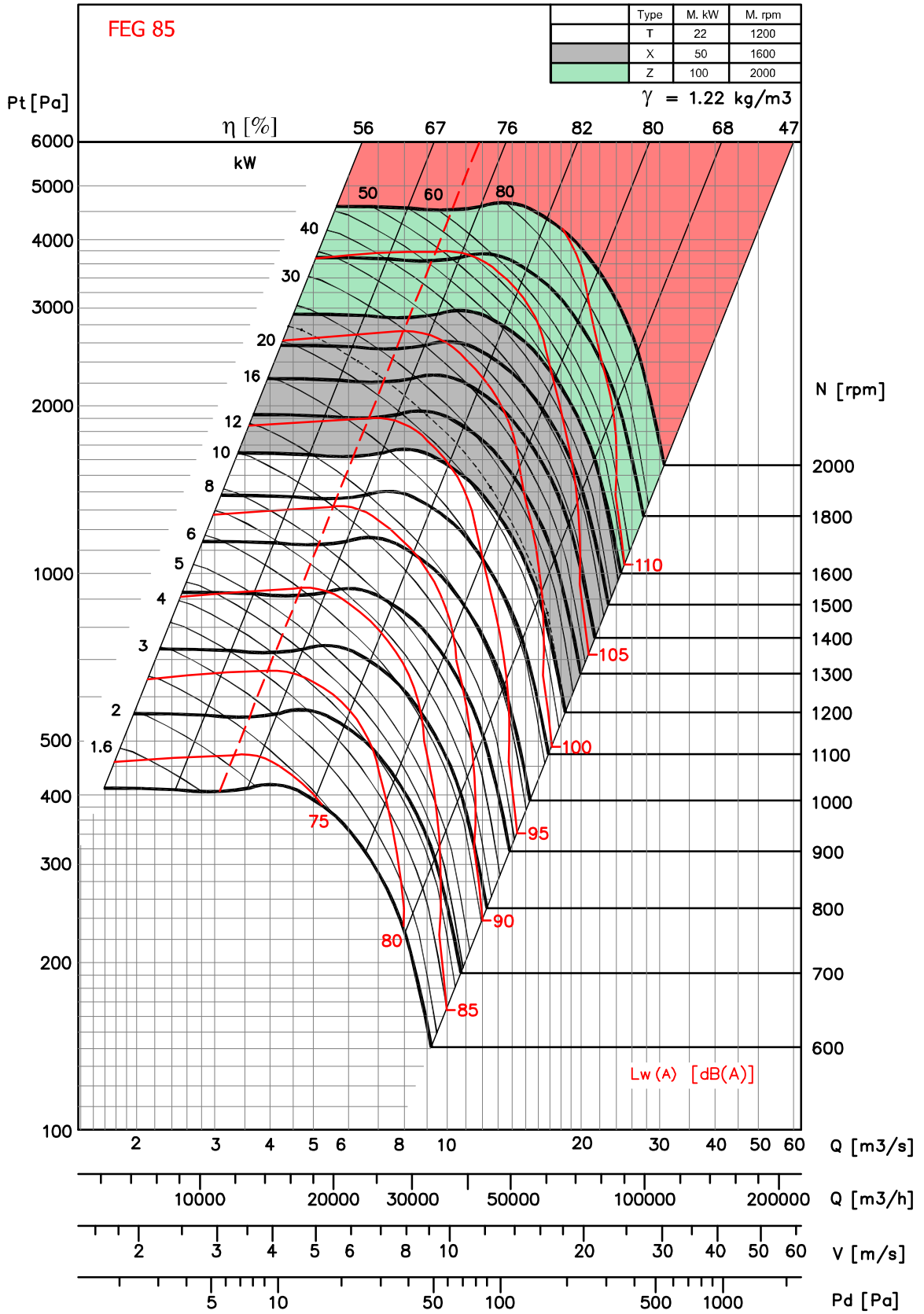

- Performance certified is for Installation type B - free inlet, ducted outlet. Performance ratings do not include the effects of appurtenances (accessories). Power rating kW does not include transmission losses.
 - The A-weighted sound ratings shown have been calculated per AMCA International Standard 301. Values shown are for inlet Lwi (A) sound power levels for installation type B - free inlet, ducted outlet.



BDB 900

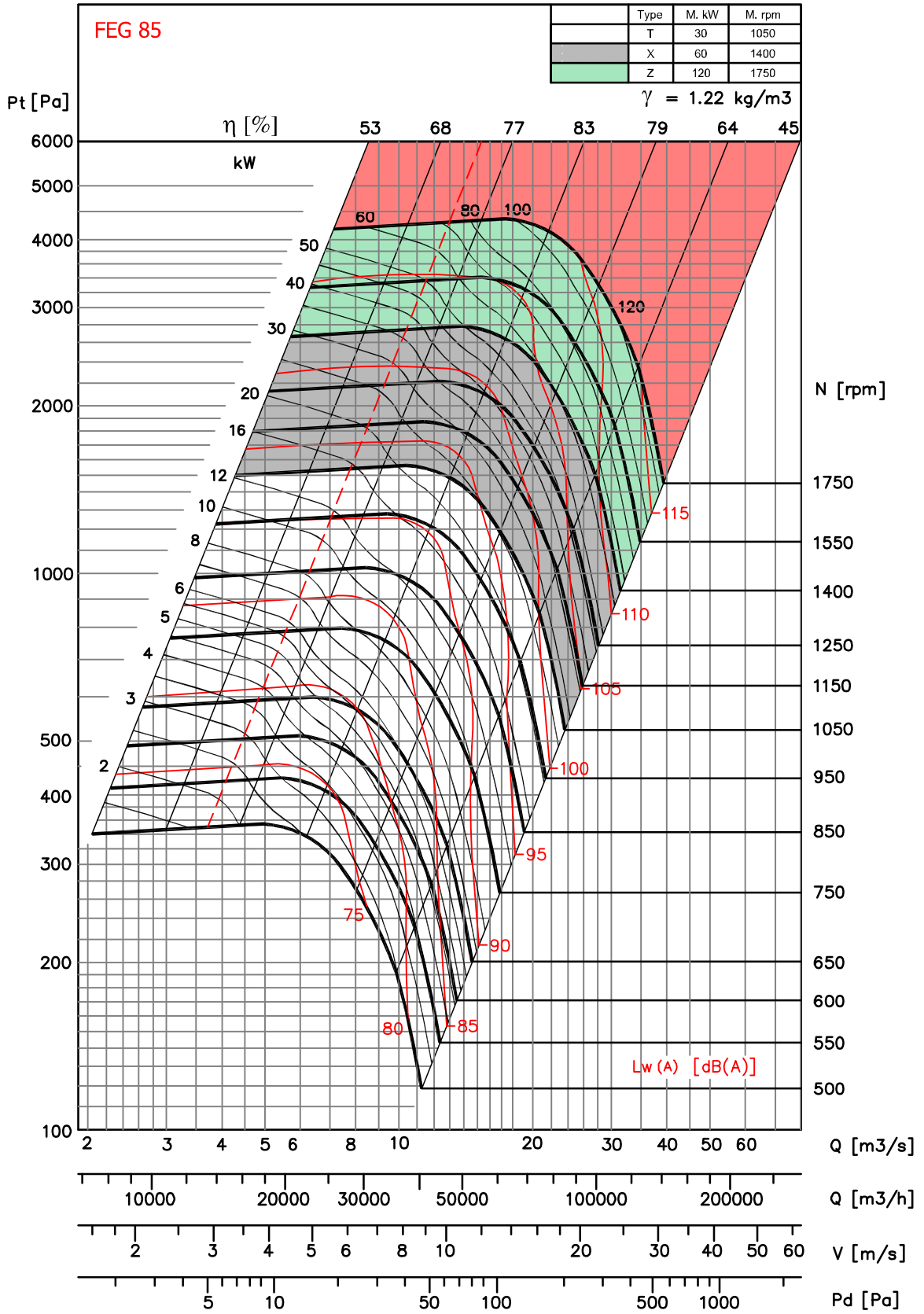

- Performance certified is for Installation type B - free inlet, ducted outlet. Performance ratings do not include the effects of appurtenances (accessories). Power rating kW does not include transmission losses.
 - The A-weighted sound ratings shown have been calculated per AMCA International Standard 301. Values shown are for inlet Lwi (A) sound power levels for installation type B - free inlet, ducted outlet.



BDB 1000

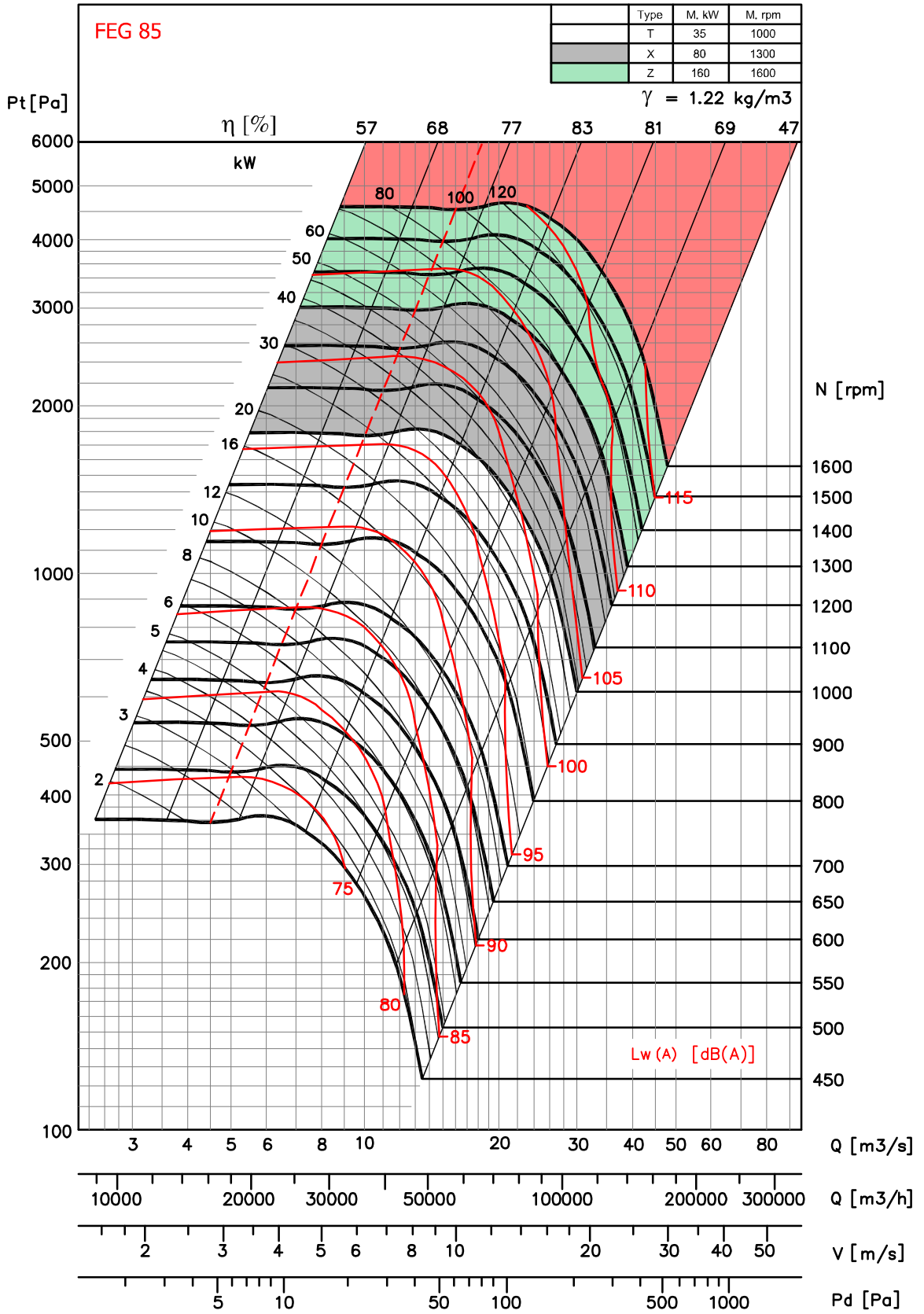

- Performance certified is for Installation type B - free inlet, ducted outlet. Performance ratings do not include the effects of appurtenances (accessories). Power rating kW does not include transmission losses.
 - The A-weighted sound ratings shown have been calculated per AMCA International Standard 301. Values shown are for inlet $L_{wi}(A)$ sound power levels for installation type B - free inlet, ducted outlet.



BDB 1120

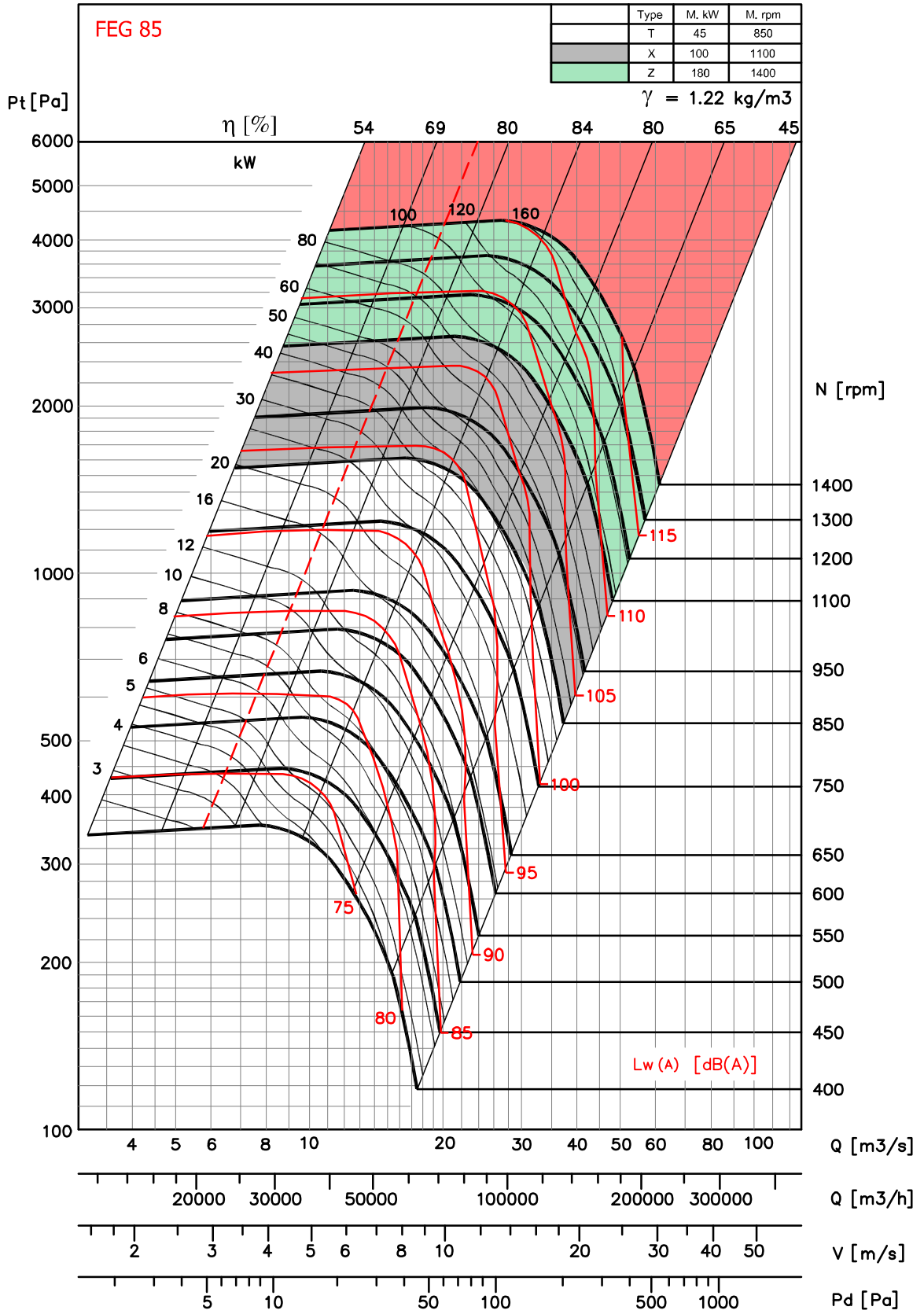

- Performance certified is for Installation type B - free inlet, ducted outlet. Performance ratings do not include the effects of appurtenances (accessories). Power rating kW does not include transmission losses.
 - The A-weighted sound ratings shown have been calculated per AMCA International Standard 301. Values shown are for inlet Lwi (A) sound power levels for installation type B - free inlet, ducted outlet.



BDB 1250

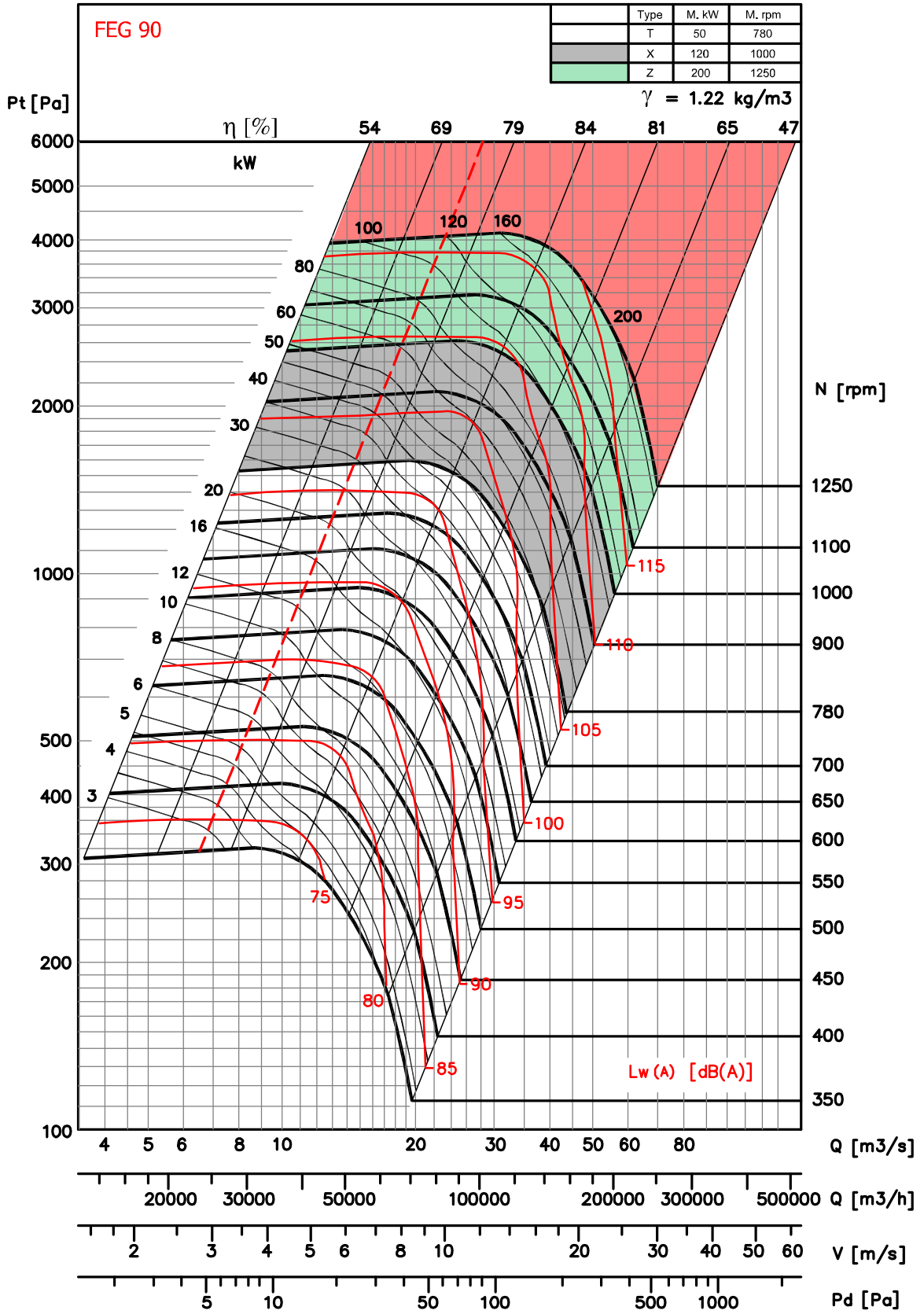

- Performance certified is for Installation type B - free inlet, ducted outlet. Performance ratings do not include the effects of appurtenances (accessories). Power rating kW does not include transmission losses.
 - The A-weighted sound ratings shown have been calculated per AMCA International Standard 301. Values shown are for inlet Lwi (A) sound power levels for installation type B - free inlet, ducted outlet.



BDB 1400

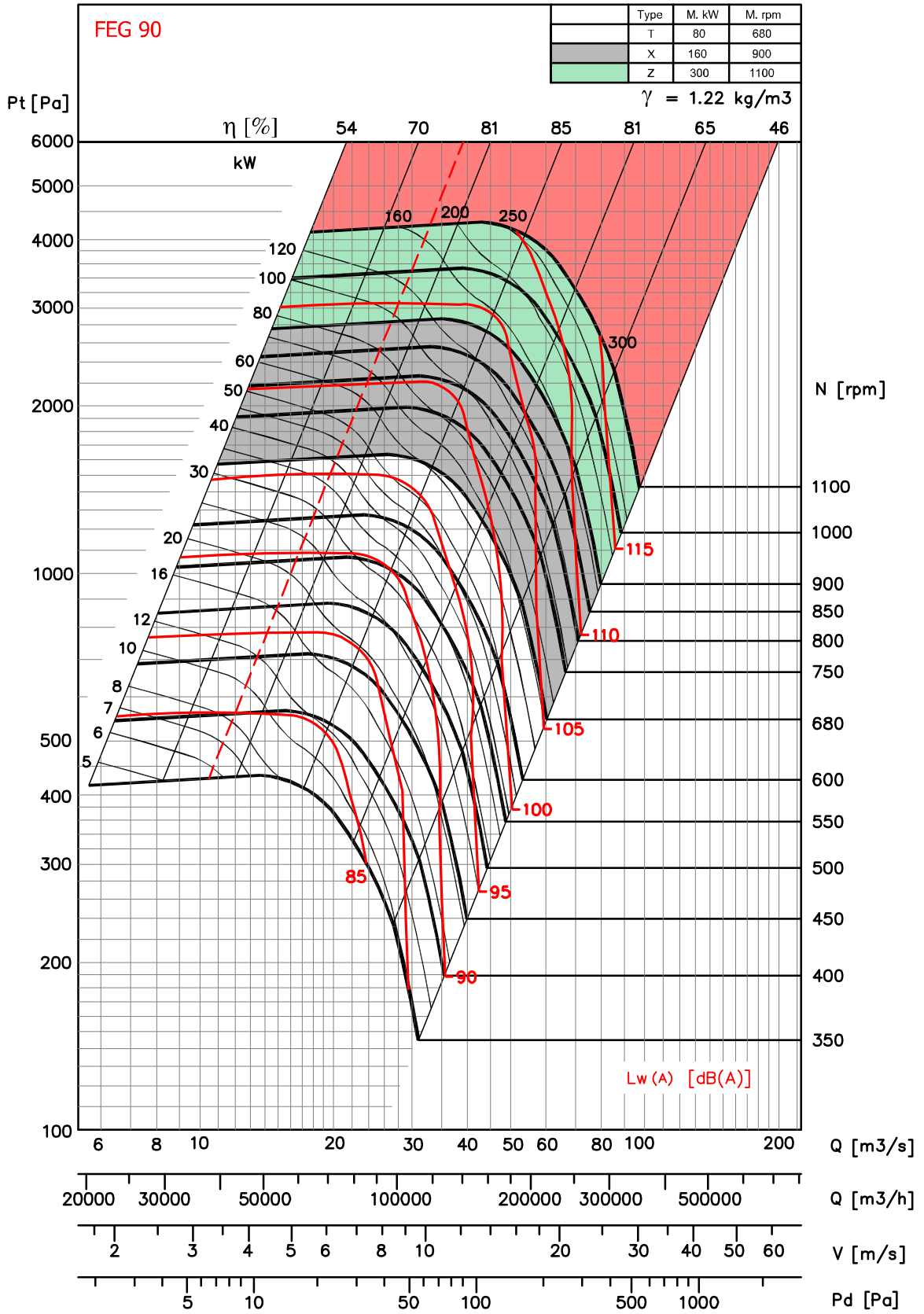

- Performance certified is for Installation type B - free inlet, ducted outlet. Performance ratings do not include the effects of appurtenances (accessories). Power rating kW does not include transmission losses.
 - The A-weighted sound ratings shown have been calculated per AMCA International Standard 301. Values shown are for inlet Lwi (A) sound power levels for installation type B - free inlet, ducted outlet.



BDB 1600

FEG 85

Op Limit	Cl.II	Cl.III
Type	X	Z
M.kW	180	400
M.RPM	750	950

$\gamma = 1.22 \text{ kg/m}^3$

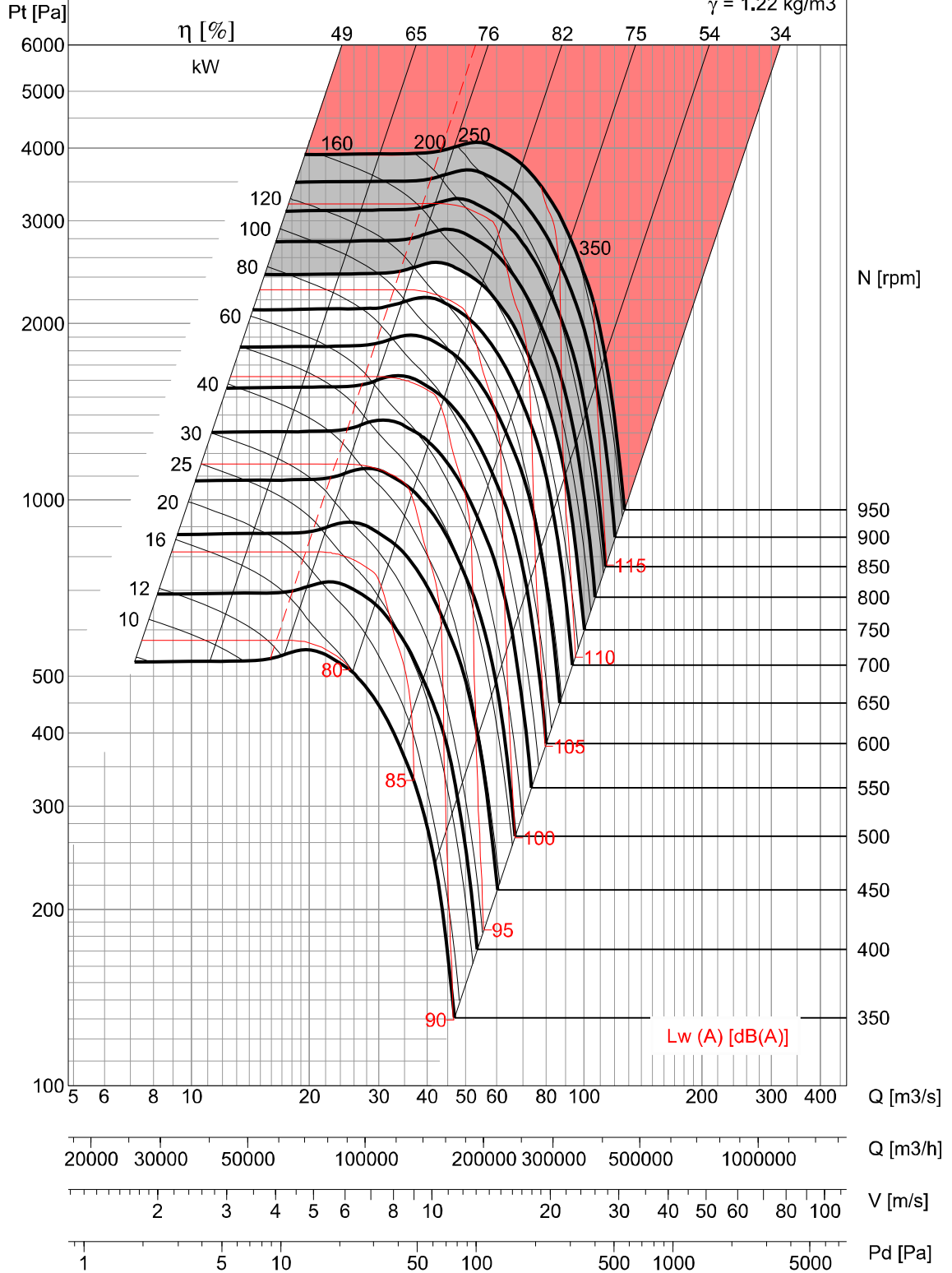

- Performance certified is for Installation type B - free inlet, ducted outlet. Performance ratings do not include the effects of appurtenances (accessories). Power rating kW does not include transmission losses.
- The A-weighted sound ratings shown have been calculated per AMCA International Standard 301. Values shown are for inlet Lwi (A) sound power levels for installation type B - free inlet, ducted outlet.



BDB 1800

FEG 85

Op Limit	Cl. II	Cl. III
Type	X	Z
M.kW	250	450
M.RPM	680	850

$\gamma = 1.22 \text{ kg/m}^3$

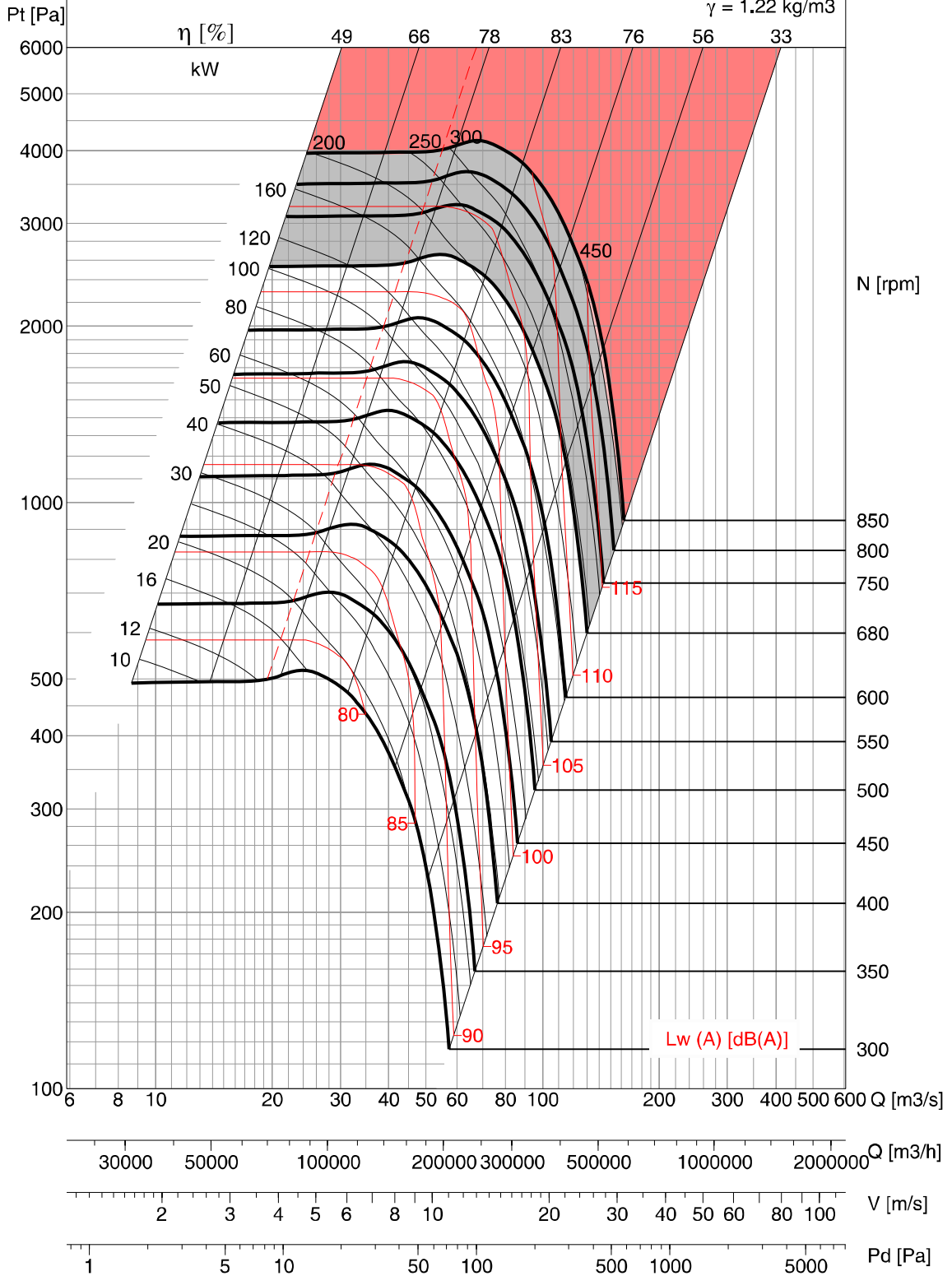

- Performance certified is for Installation type B - free inlet, ducted outlet. Performance ratings do not include the effects of appurtenances (accessories). Power rating kW does not include transmission losses.
- The A-weighted sound ratings shown have been calculated per AMCA International Standard 301. Values shown are for inlet Lwi (A) sound power levels for installation type B - free inlet, ducted outlet.



BDB 2000

FEG 85

Op Limit	Cl. II	Cl. III
Type	X	Z
M.kW	300	600
M.RPM	600	750

$\gamma = 1.22 \text{ kg/m}^3$

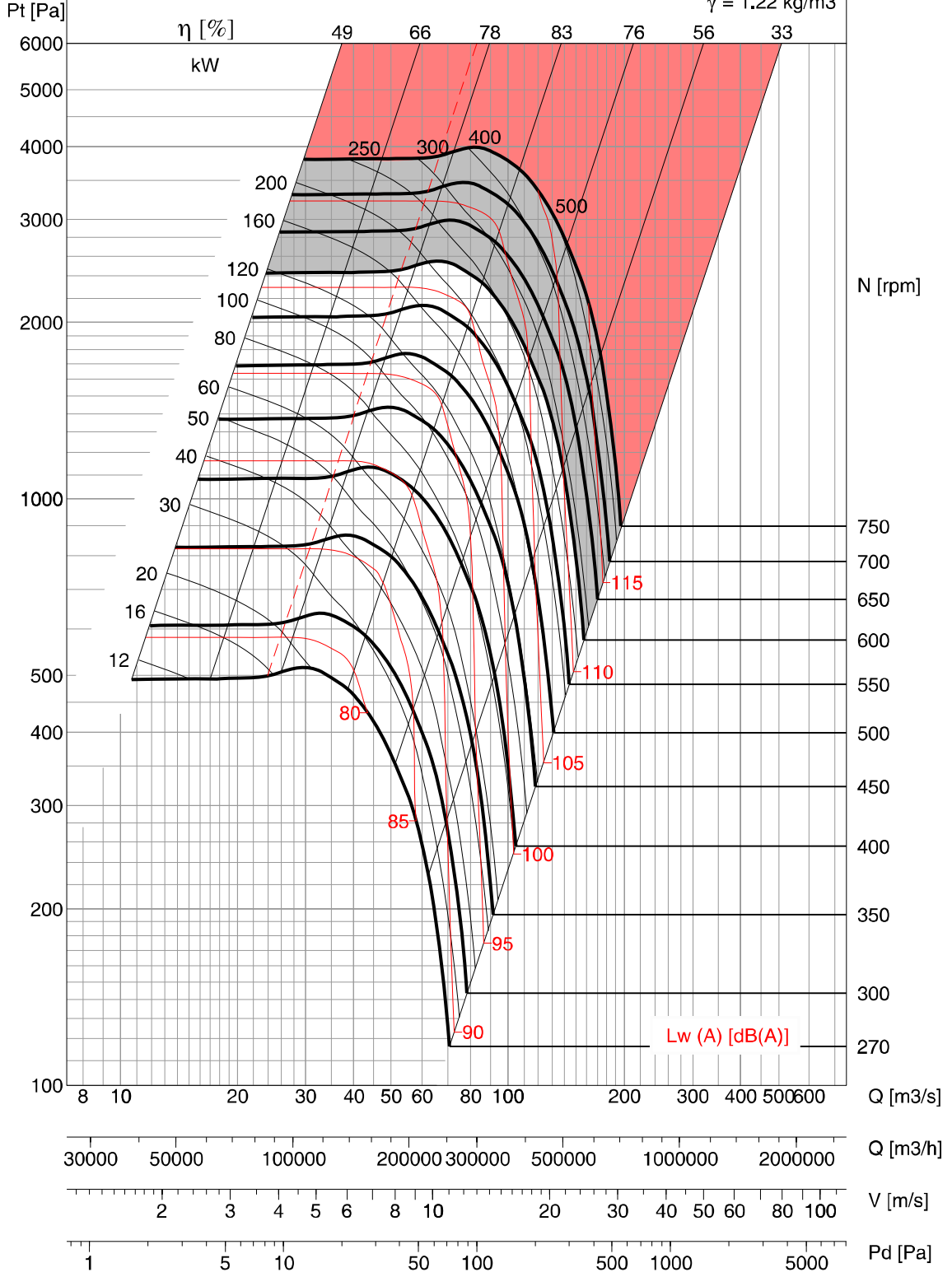

- Performance certified is for Installation type B - free inlet, ducted outlet. Performance ratings do not include the effects of appurtenances (accessories). Power rating kW does not include transmission losses.
- The A-weighted sound ratings shown have been calculated per AMCA International Standard 301. Values shown are for inlet Lwi (A) sound power levels for installation type B - free inlet, ducted outlet.

BDB 315-400 'S'

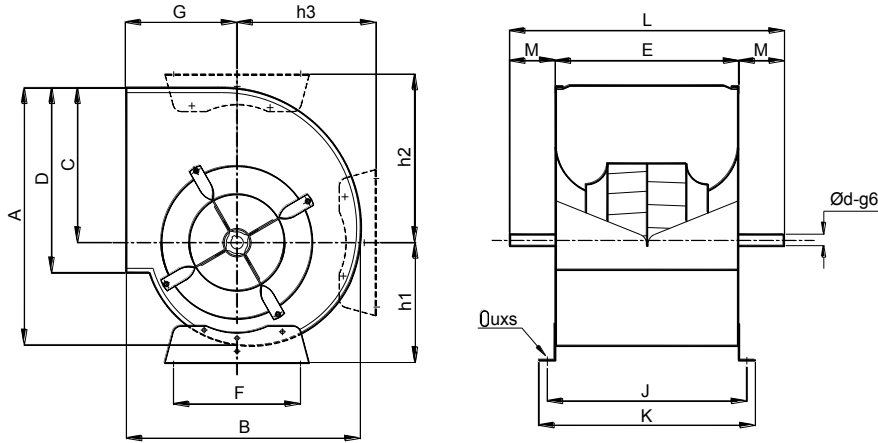

Model	A	B	C	D	E	F	G	J	K	L	M	h1	h2	h3	Ød		uxs
															SL	SM	
315	572	516	340	404	404	280	236	434	464	600	98	261	370	283	25	25	11x16
355	644	576	383	452	452	315	260	492	532	672	110	274	411	320	30	30	11x16
400	724	644	432	506	506	355	290	546	586	726	110	302	462	359	30	30	11x16

All Dimensions in mm.

BDB 450-710 'S'

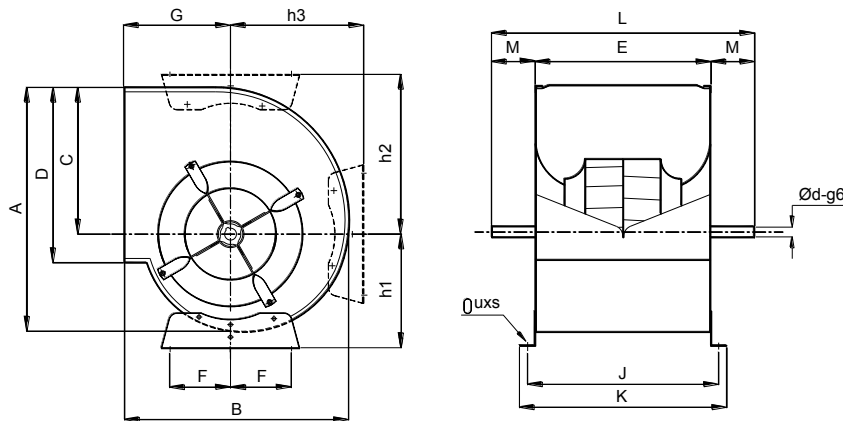

Model	A	B	C	D	E	F	G	J	K	L	M	h1	h2	h3	Ød		uxs
															SL	SM	
450	816	722	486	568	568	200	322	608	648	814	123	336	518	407	35	35	13x18
500	906	794	538	638	638	225	352	678	718	924	143	375	568	448	35	35	13x18
560	1016	886	603	714	714	250	390	764	814	1000	143	416	634	502	40	40	13x18
630	1142	992	679	800	800	280	434	850	900	1092	146	468	707	571	40	45	13x18
710	1286	1114	765	898	898	315	484	948	998	1234	168	531	797	636	50	50	13x18

All Dimensions in mm.

BDB 315-400 'C'

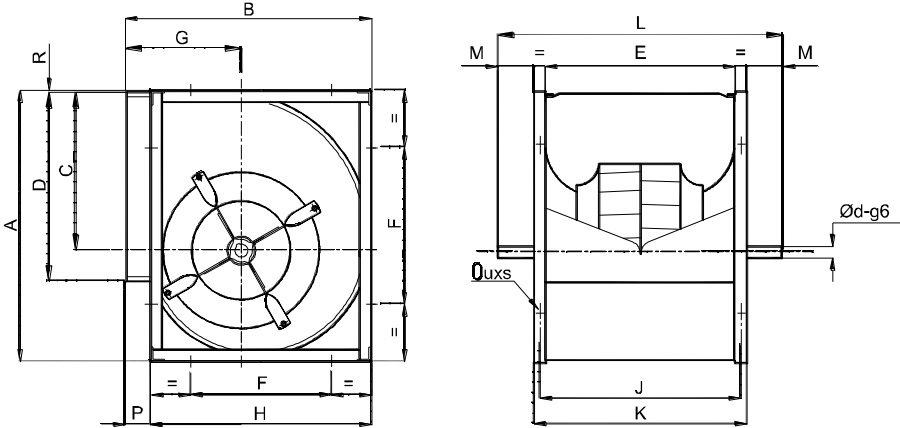

Model	A	B	C	D	E	F	G	H	J	K	L	M	P	R	Ød		uxs
															CL	CM	
315	578	518	340	404	404	330	236	480	434	464	600	68	38	3	25	25	13x18
355	654	578	383	452	452	368	260	548	492	532	672	70	30	6	30	30	13x18
400	736	650	432	506	506	402	290	612	546	586	726	70	38	5	30	30	13x18

All Dimensions in mm.

BDB 450-710 'C'

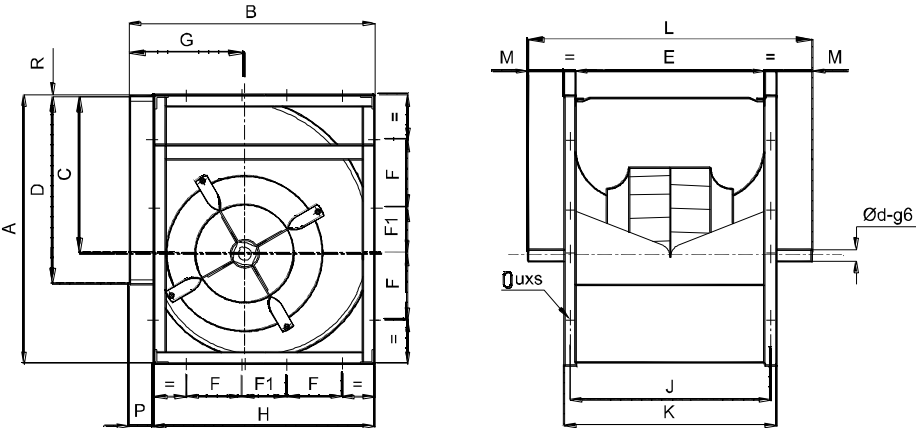

Model	A	B	C	D	E	F	F1	G	H	J	K	L	M	P	R	Ød		uxs
																CL	CM	
450	827	726	486	568	568	200	111	322	681	608	648	814	83	45	5	35	35	13x18
500	918	800	538	638	638	245	120	352	750	678	718	924	103	50	5	35	35	13x18
560	1030	892	603	714	714	280	125	390	844	764	814	1000	93	48	7	40	40	13x18
630	1157	998	679	800	800	328	110	434	945	850	900	1092	96	53	6	40	45	13x18
710	1302	1120	765	898	898	360	150	484	1057	948	998	1234	118	63	7	50	50	17x22

All Dimensions in mm.

BDB 315-400 'T'

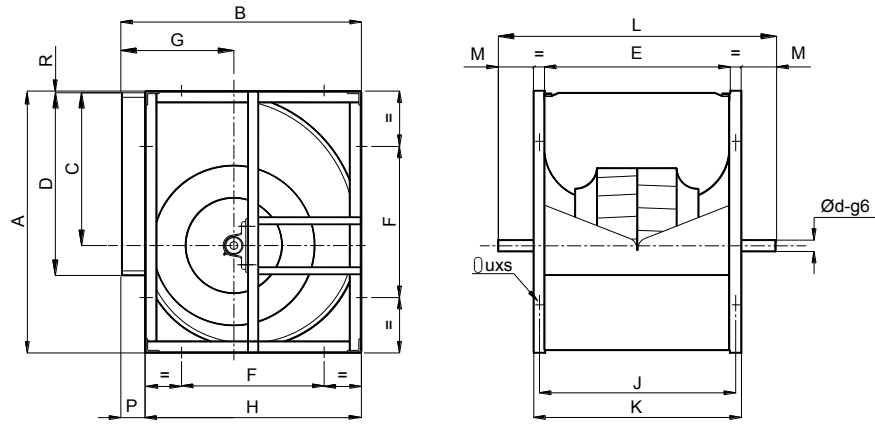

Model	A	B	C	D	E	F	G	H	J	K	L	M	P	R	Ød		uxs
															TL	TM	
315	578	518	340	404	404	330	236	480	434	464	632	84	38	3	30	30	13x18
355	654	578	383	452	452	368	260	548	492	532	718	93	30	6	35	35	13x18
400	736	650	432	506	506	402	290	612	546	586	772	93	38	5	35	35	13x18

All Dimensions in mm.

BDB 450-1000 'T'

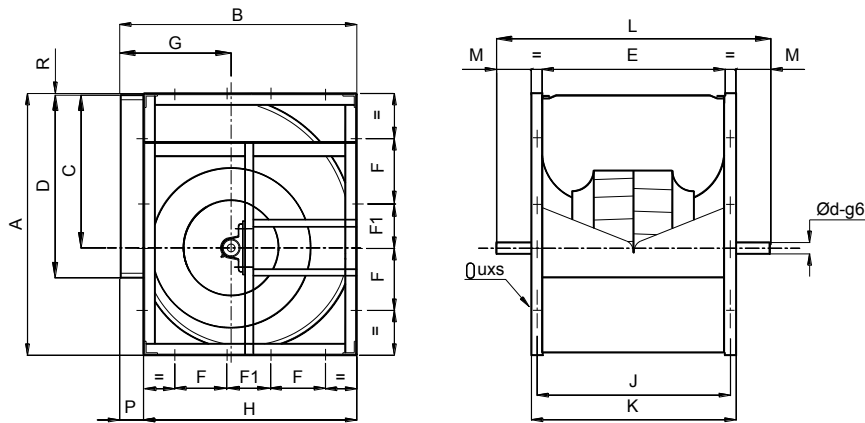

Model	A	B	C	D	E	F	F1	G	H	J	K	L	M	P	R	Ød		uxs
																TL	TM	
450	827	726	486	568	568	200	111	322	681	608	648	878	115	45	5	40	40	13x18
500	918	800	538	638	638	245	120	352	750	678	718	956	119	50	5	40	45	13x18
560	1030	892	603	714	714	280	125	390	844	764	814	1080	133	48	7	45	45	13x18
630	1157	998	679	800	800	328	110	434	945	850	900	1166	133	53	6	50	50	13x18
710	1302	1120	765	898	898	360	150	484	1057	948	998	1280	141	63	7	50	55	17x22
800	1468	1254	862	1006	1006	405	171	540	1180	1056	1106	1388	141	74	7	55	55	17x22
900	1648	1408	971	1130	1130	455	189	604	1319	1180	1230	1566	168	89	7	60	60	17x22
1000	1810	1540	1066	1266	1266	500	200	656	1450	1316	1366	1724	179	90	9	60	70	17x22

All Dimensions in mm.

BDB 1120-1400 'T'

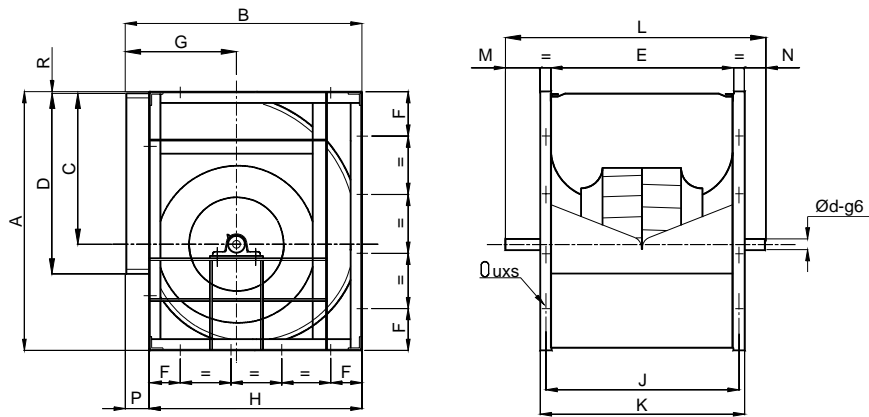

Model	A	B	C	D	E	F	G	H	J	K	L	M	N	P	R	Ød		uxs
																TL	TM	
1120	2033	1725	1200	1422	1422	290	748	1630	1482	1548	1800	193	59	95	9	-	75	17x22
1250	2285	1930	1353	1524	1524	300	830	1831	1599	1674	1975	220	81	99	9	-	80	17x22
1400	2568	2170	1515	1794	1794	310	963	2057	1869	1944	2260	227	89	113	13	-	80	17x22

All Dimensions in mm.

BDB 315-400 'XM'

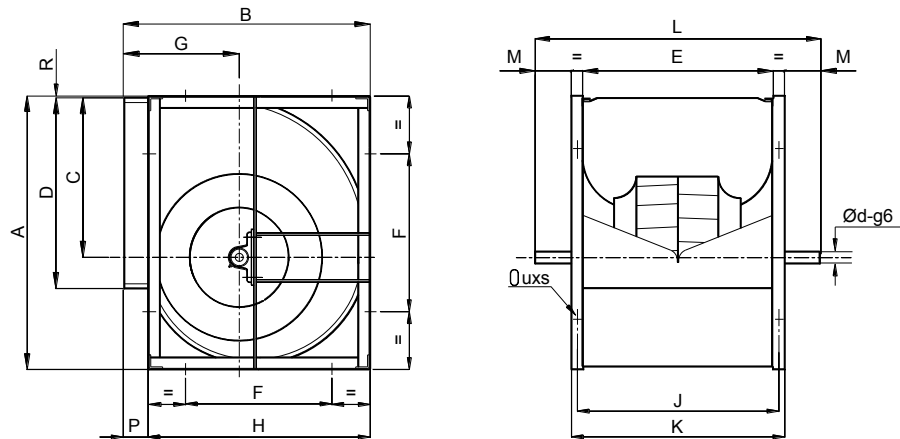

Model	A	B	C	D	E	F	G	H	J	K	L	M	P	R	Ød	uxs
315	578	518	340	404	404	330	236	480	434	464	732	134	38	3	35	13x18
355	654	578	383	452	452	368	260	548	492	532	822	145	30	6	40	13x18
400	736	650	432	506	506	402	290	612	546	586	876	145	38	5	40	13x18

All Dimensions in mm.

BDB 450-1000 'XM'

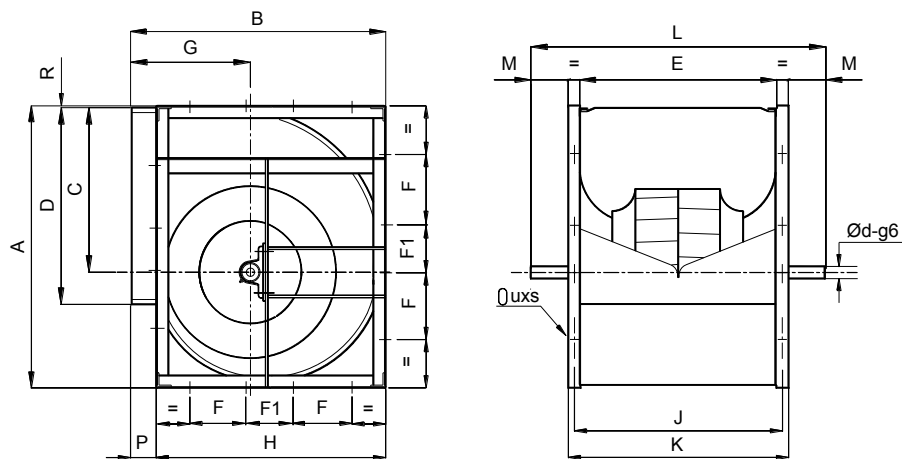

Model	A	B	C	D	E	F	F1	G	H	J	K	L	M	P	R	Ød	uxs
450	827	726	486	568	568	200	111	322	681	608	648	946	149	45	5	45	13x18
500	918	800	538	638	638	245	120	352	750	678	718	1066	174	50	5	50	13x18
560	1030	892	603	714	714	280	125	390	844	764	814	1138	162	48	7	55	13x18
630	1157	998	679	800	800	328	110	434	945	850	900	1286	193	53	6	60	13x18
710	1302	1120	765	898	898	360	150	484	1057	948	998	1390	196	63	7	65	17x22
800	1468	1254	862	1006	1006	405	171	540	1180	1056	1106	1498	196	74	7	65	17x22
900	1648	1408	971	1130	1130	455	189	604	1319	1180	1230	1660	215	89	7	70	17x22
1000	1810	1540	1066	1266	1266	500	200	656	1450	1316	1366	1845	239.5	90	9	80	17x22

All Dimensions in mm.

BDB 1120-1400 'XX'

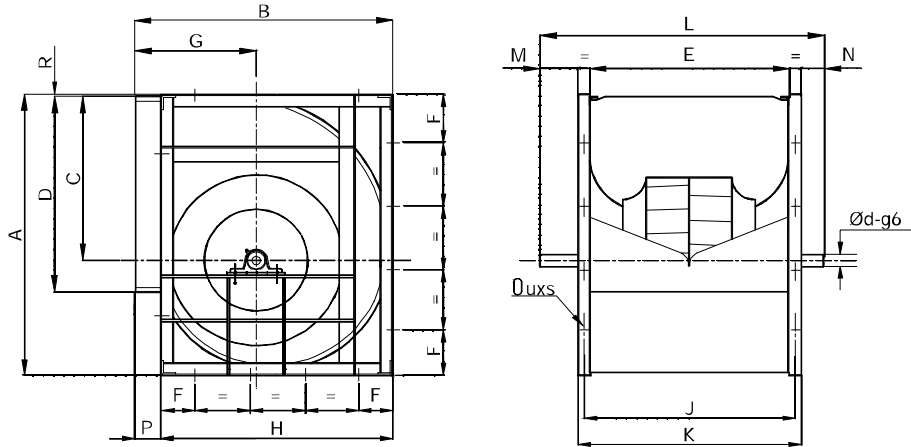

Model	A	B	C	D	E	F	G	H	J	K	L	M	N	P	R	Ød	uxs
1120	2033	1725	1200	1422	1422	290	748	1630	1482	1548	1916	266	102	95	9	80	17x22
1250	2285	1930	1353	1524	1524	300	830	1831	1599	1674	2035	265	96	99	9	85	17x22
1400	2568	2170	1515	1794	1794	310	963	2057	1869	1944	2295	256	95	113	13	90	17x22

All Dimensions in mm.

BDB 1600-2000'X'

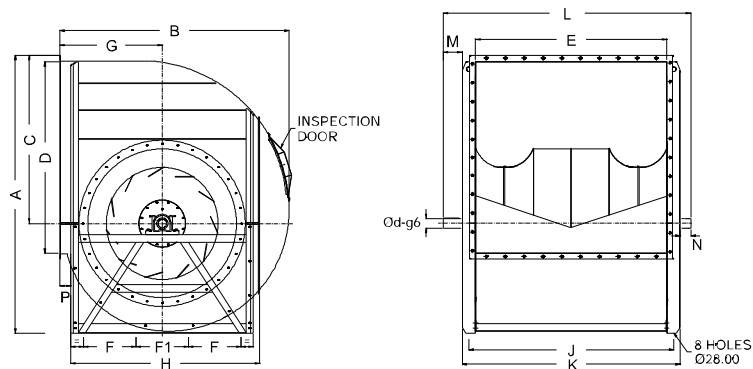

Model	A	B	C	D	E	F	F1	G	H	J	K	L	M	N	P	Ød
1600	2950	2486	1790	2185	2025	550	600	1086	2132	2175	2325	2550	190	35	116	90
1800	3310	2798	2000	2438	2278	620	630	1220	2380	2458	2638	2890	220	32	135	110
2000	3715	3142	2246	2725	2530	700	710	1375	2690	2745	2925	3230	250	55	150	115

All Dimensions in mm.

BDB 1600-2000'Z'

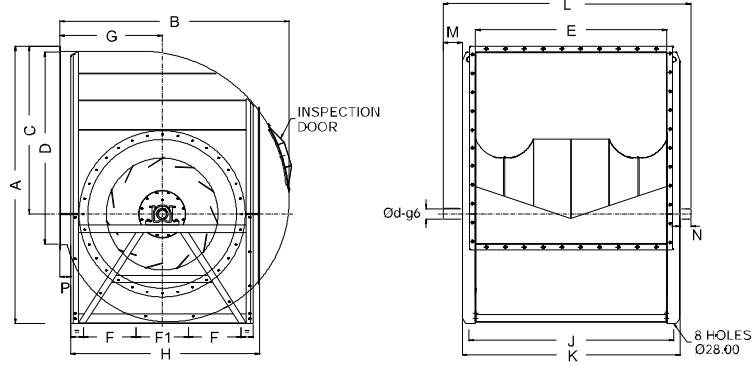

Model	A	B	C	D	E	F	F1	G	H	J	K	L	M	N	P	Ød
1600	2950	2486	1790	2185	2025	550	600	1086	2132	2175	2325	2550	190	35	116	110
1800	3310	2798	2000	2438	2278	620	630	1220	2380	2458	2638	2890	220	32	135	125
2000	3715	3142	2246	2725	2530	700	710	1375	2690	2745	2925	3230	250	55	150	135

All Dimensions in mm.

BDB 315-400 'S2M'

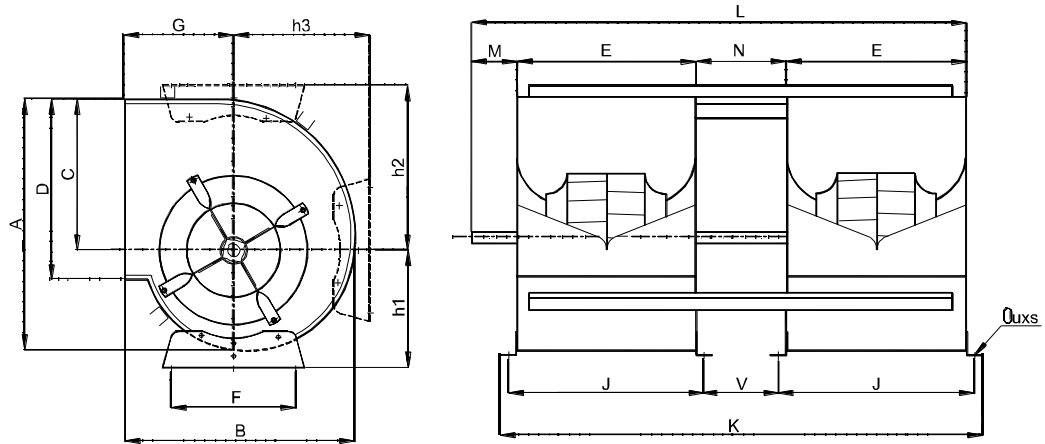

Model	A	B	C	D	E	F	G	J	K	L	M	V	X	h1	h2	h3	Ød	uxs
315	572	516	340	404	404	280	236	434	1183	1233	110	285	315	261	370	283	30	11x16
355	644	576	383	452	452	315	260	492	1339	1389	130	315	355	274	411	320	35	11x16
400	724	644	432	506	506	355	290	546	1492	1542	130	360	400	302	462	359	35	11x16

All Dimensions in mm.

BDB 450-500 'S2M'

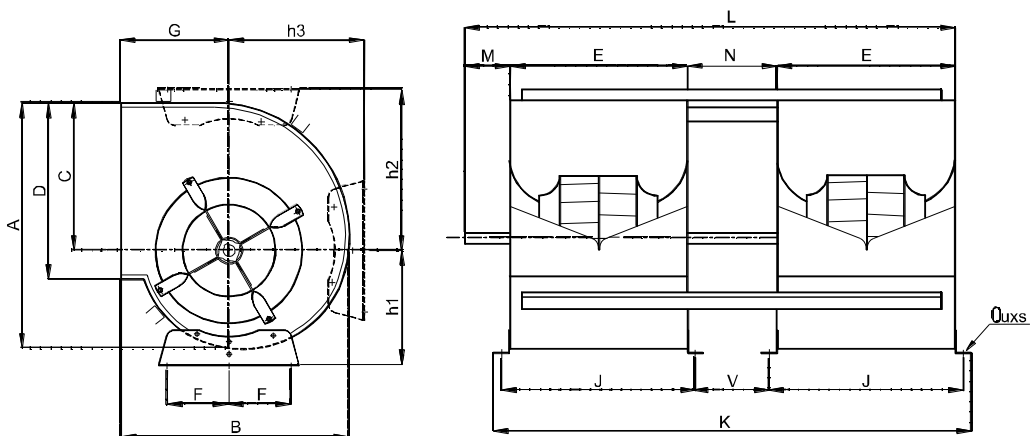

Model	A	B	C	D	E	F	G	J	K	L	M	V	X	h1	h2	h3	Ød	uxs
450	816	722	486	568	568	200	322	608	1666	1726	140	410	450	336	518	407	40	13x18
500	906	794	538	638	638	225	352	678	1856	1916	140	460	500	375	568	448	40	13x18

All Dimensions in mm.

BDB 315-400 'C2M'

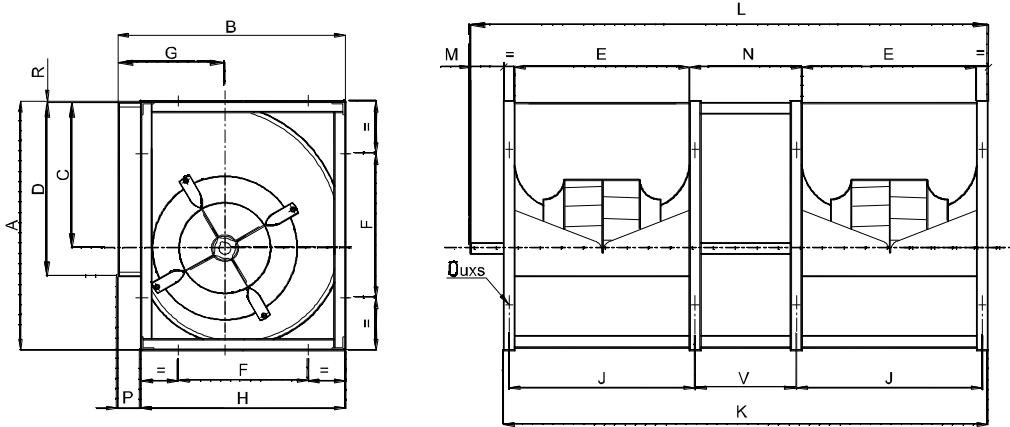

Model	A	B	C	D	E	F	G	H	J	K	L	M	P	R	V	X	Ød	uxs
315	578	518	340	404	404	330	236	480	434	1183	1263	80	38	3	285	315	30	13x18
355	654	578	383	452	452	368	260	548	492	1339	1429	90	30	6	315	355	35	13x18
400	736	650	432	506	506	402	290	612	546	1492	1582	90	38	5	360	400	35	13x18

All Dimensions in mm.

BDB 450-500 'C2M'

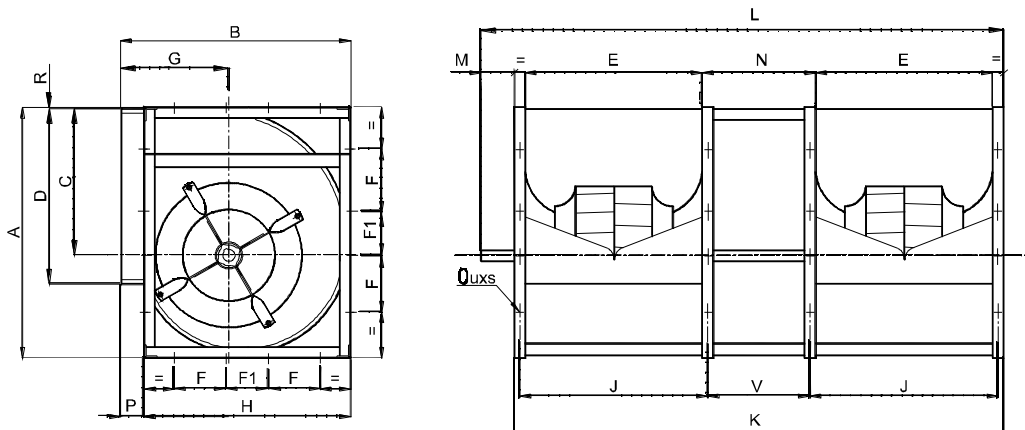

Model	A	B	C	D	E	F	F1	G	H	J	K	L	M	P	R	V	X	Ød	uxs
450	827	726	486	568	568	200	111	322	681	608	1666	1766	100	45	5	410	450	40	13x18
500	918	800	538	638	638	245	120	352	750	678	1856	1956	100	50	5	460	500	40	13x18

All Dimensions in mm.

BDB 355-400 'T2M'

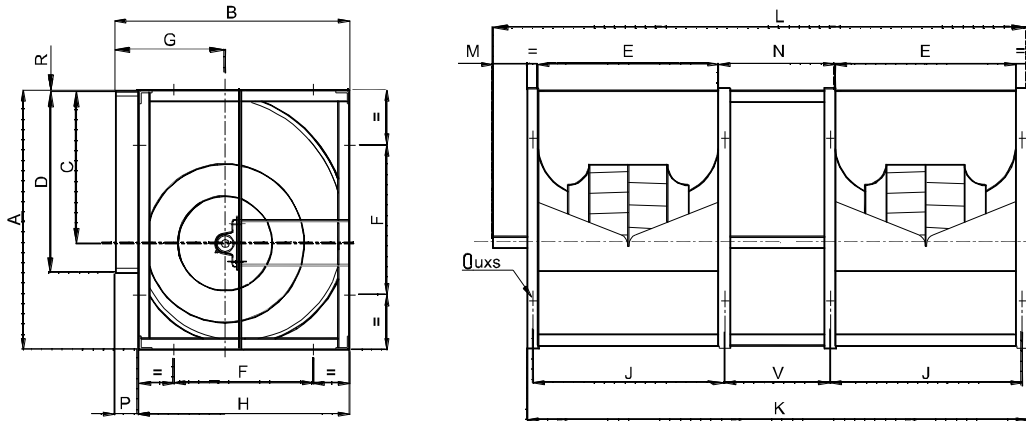

Model	A	B	C	D	E	F	G	H	J	K	L	M	P	R	V	X	Ød	uxs
355	654	578	383	452	452	368	260	548	492	1339	1449	110	30	6	315	355	40	13x18
400	736	650	432	506	506	402	290	612	546	1492	1627	135	38	5	360	400	45	13x18

All Dimensions in mm.

BDB 450-630 'T2M'

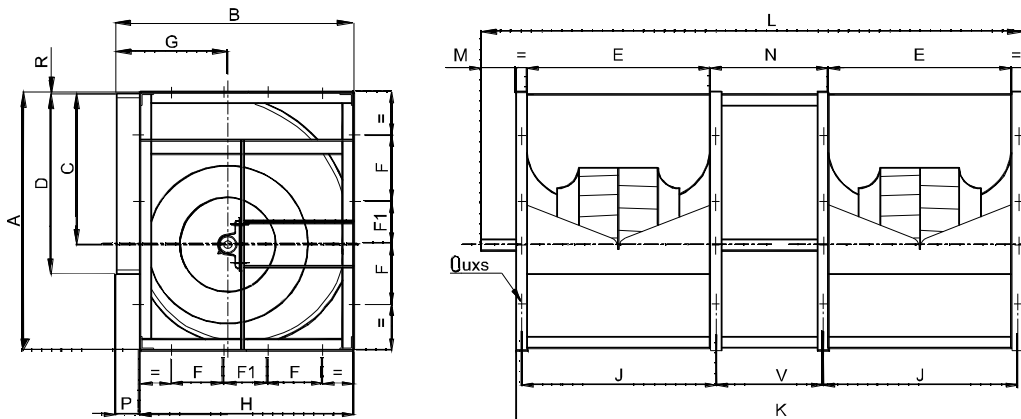

Model	A	B	C	D	E	F	F1	G	H	J	K	L	M	P	R	V	X	Ød	uxs
450	827	726	486	568	568	200	111	322	681	608	1666	1801	135	45	5	410	450	50	13x18
500	918	800	538	638	638	245	120	352	750	678	1856	1991	135	50	5	460	500	55	13x18
560	1030	892	603	714	714	280	125	390	844	764	2088	2228	140	48	7	510	560	55	13x18
630	1157	998	679	800	800	328	110	434	945	850	2330	2470	140	53	6	580	630	60	13x18

All Dimensions in mm.

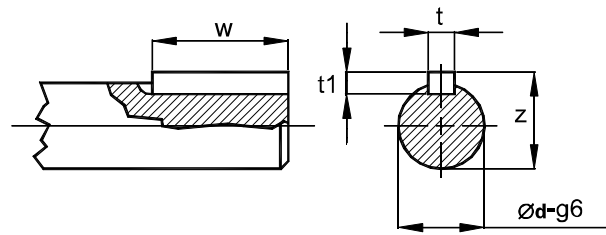

$\varnothing d$	t	t1	w	z
25	8	7	40	28
30	8	7	40	33
35	10	8	50	38
40	12	8	70	43
45	14	9	70	48,5
50	14	9	90	53,5
55	16	10	90	59
60	18	11	90	64
70	20	12	110	74,5
75	20	12	110	79,9
80	22	14	110	85
85	22	14	110	90
90	25	14	140	95
110	28	16	160	116
115	32	18	160	122
125	32	18	180	132
135	36	20	180	143

All Dimensions in mm.

OVERALL DIMENSION – BDB “S” SERIES

CW 90° (Pos Z)

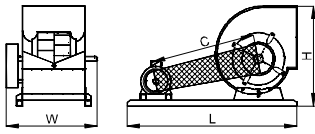

CW 270° (Pos W)

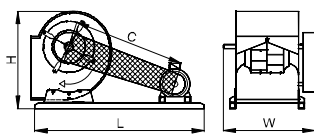

CW 360° (Pos W)

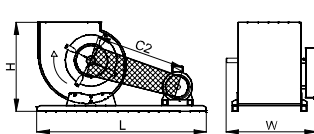

CW 360° (Pos Z)

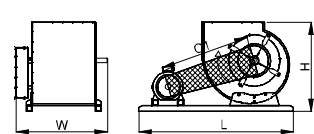

CCW 90° (Pos W)

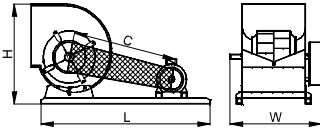

CCW 270° (Pos Z)

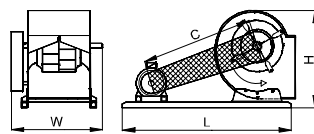

CCW 360° (Pos W)

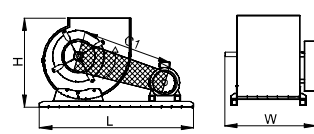

CCW 360° (Pos Z)

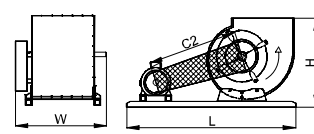

Model	Motor Frame Size	90°/ 270°						360°					
		C (90°)	C (270°)	L	W	H	* Wt (kg)	C1	C2	L	W	H	* Wt (kg)
315	71	445	493	780	630	641	32	551	449	880	630	559	33
	80	472	515	820	630	641	32	577	475	920	630	559	33
	90	498	537	860	630	641	33	604	500	960	630	559	33
	100	524	559	900	630	641	33	630	526	1000	630	559	33
	112	549	580	940	630	641	33	655	550	1040	630	559	34
	132	605	630	1020	630	641	34	711	604	1120	630	559	34
355	71	483	545	840	702	697	44	611	498	960	702	620	45
	80	510	566	880	702	697	44	618	504	980	702	620	45
	90	536	588	920	702	697	44	644	528	1020	702	620	45
	100	562	610	960	702	697	45	670	553	1060	702	620	45
	112	606	648	1020	702	697	45	713	595	1120	702	620	45
	132	662	696	1100	702	697	45	767	648	1200	702	620	46
400	71	540	615	920	756	774	50	671	543	1040	756	689	50
	80	547	619	940	756	774	50	696	567	1080	756	689	50
	90	572	639	980	756	774	50	721	590	1120	756	689	51
	100	598	660	1020	756	774	50	747	614	1160	756	689	51
	112	642	697	1080	756	774	50	770	637	1200	756	689	51
	132	696	743	1160	756	774	51	843	707	1300	756	689	52
450	71	753	791	1250	756	774	51	908	771	1400	756	689	52
	80	604	690	1020	844	862	66	753	612	1160	844	769	67
	90	629	709	1060	844	862	67	777	634	1200	844	769	67
	100	654	730	1100	844	862	67	811	666	1250	844	769	68
	112	677	748	1140	844	862	67	843	696	1300	844	769	68
	132	711	774	1200	844	862	67	866	718	1350	844	769	68
500	160	825	874	1350	844	862	68	929	778	1450	844	769	69
	80	631	728	1080	954	963	88	801	648	1250	954	850	90
	90	655	746	1120	954	963	89	834	679	1300	954	850	90
	100	679	765	1160	954	963	89	868	711	1350	954	850	90
	112	702	783	1200	954	963	89	900	740	1400	954	850	91
	132	773	843	1300	954	963	90	922	761	1450	954	850	91
560	160	837	896	1400	954	963	91	984	820	1550	954	850	92
	90	709	819	1200	1030	1069	111	906	735	1400	1030	942	112
	100	742	845	1250	1030	1069	111	939	766	1450	1030	942	113
	112	774	870	1300	1030	1069	112	970	794	1500	1030	942	113
	132	844	928	1400	1030	1069	112	991	814	1550	1030	942	114
	160	907	980	1500	1030	1069	113	1099	918	1700	1030	942	115
630	180	981	1044	1600	1030	1069	114	1123	940	1750	1030	942	115
	90	781	908	1300	1122	1197	135	1025	834	1550	1122	1055	137
	100	814	933	1350	1122	1197	136	1057	864	1600	1122	1055	138
	112	844	957	1400	1122	1197	136	1088	891	1650	1122	1055	138
	132	913	1014	1500	1122	1197	137	1108	909	1700	1122	1055	139
	160	974	1062	1600	1122	1197	138	1167	964	1800	1122	1055	139
710	180	1046	1125	1700	1122	1197	139	1238	1032	1900	1122	1055	140
	90	871	1011	1450	1264	1376	204	1109	893	1700	1264	1200	207
	100	904	1037	1500	1264	1376	205	1141	923	1750	1264	1200	208
	112	935	1061	1550	1264	1376	205	1171	950	1800	1264	1200	208
	132	956	1074	1600	1264	1376	206	1192	968	1850	1264	1200	209
	160	1016	1121	1700	1264	1376	207	1250	1022	1950	1264	1200	210
710	180	1087	1182	1800	1264	1376	208	1321	1089	2050	1264	1200	211
	200	1160	1245	1900	1264	1376	210	1344	1111	2100	1264	1200	212

* The above weight does not include motor and drive unit as these will vary with supplier.

All Dimensions in mm.

OVERALL DIMENSION – BDB “C” SERIES

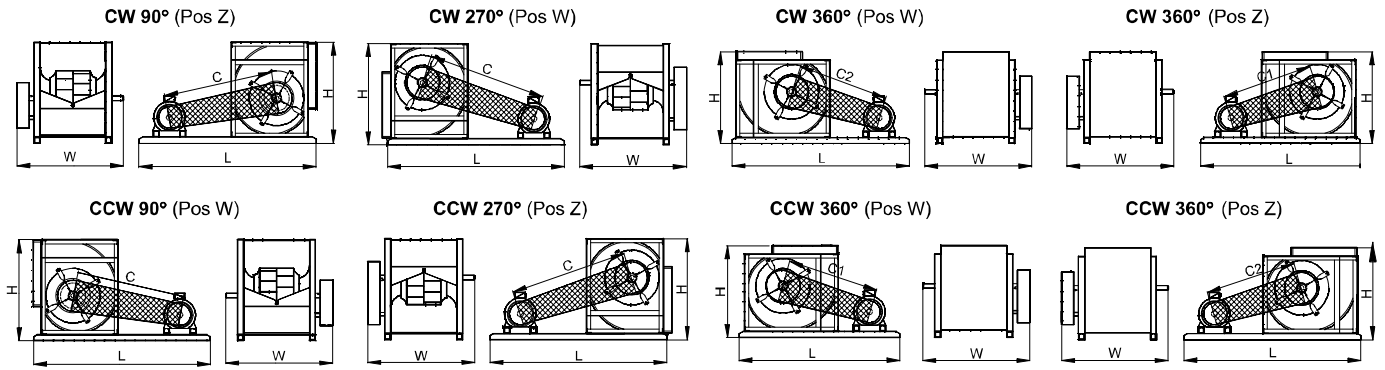

Model	Motor Frame Size	90°/ 270°						360°					
		C (90°)	C (270°)	L	W	H	* Wt (kg)	C1	C2	L	W	H	* Wt (kg)
315	71	460	500	780	630	618	33	534	433	880	630	558	34
	80	488	524	820	630	618	33	561	459	920	630	558	34
	90	515	547	860	630	618	34	587	484	960	630	558	34
	100	542	571	900	630	618	34	614	509	1000	630	558	34
	112	568	594	940	630	618	34	638	533	1040	630	558	35
	132	625	645	1020	630	618	35	694	587	1120	630	558	35
355	71	496	547	840	702	694	48	593	479	960	702	618	49
	80	523	570	880	702	694	48	601	485	980	702	618	49
	90	549	592	920	702	694	48	626	509	1020	702	618	49
	100	576	615	960	702	694	49	652	534	1060	702	618	49
	112	620	654	1020	702	694	49	695	575	1120	702	618	49
	132	676	704	1100	702	694	49	749	628	1200	702	618	50
400	71	561	621	920	756	776	53	651	527	1040	756	690	53
	80	569	626	940	756	776	53	677	550	1080	756	690	53
	90	595	647	980	756	776	53	702	573	1120	756	690	54
	100	621	669	1020	756	776	53	727	597	1160	756	690	54
	112	664	708	1080	756	776	53	750	619	1200	756	690	54
	132	719	756	1160	756	776	54	823	689	1300	756	690	55
450	80	633	701	1020	844	867	70	733	593	1160	844	766	71
	90	658	722	1060	844	867	71	757	615	1200	844	766	71
	100	684	743	1100	844	867	71	791	647	1250	844	766	72
	112	707	763	1140	844	867	71	824	678	1300	844	766	72
	132	741	790	1200	844	867	71	846	699	1350	844	766	72
	160	856	894	1350	844	867	72	909	759	1450	844	766	73
500	80	661	740	1080	954	968	95	779	629	1250	954	850	97
	90	686	760	1120	954	968	96	812	659	1300	954	850	97
	100	711	780	1160	954	968	96	845	691	1350	954	850	97
	112	734	799	1200	954	968	96	877	720	1400	954	850	98
	132	805	861	1300	954	968	97	899	740	1450	954	850	98
	160	870	917	1400	954	968	98	961	799	1550	954	850	99
560	90	739	830	1200	1030	1080	126	884	714	1400	1030	942	127
	100	773	858	1250	1030	1080	126	916	744	1450	1030	942	128
	112	804	884	1300	1030	1080	127	947	773	1500	1030	942	128
	132	875	945	1400	1030	1080	127	968	792	1550	1030	942	129
	160	938	998	1500	1030	1080	128	1076	895	1700	1030	942	130
	180	1012	1064	1600	1030	1080	129	1100	917	1750	1030	942	130
630	90	816	923	1300	1122	1207	158	998	811	1550	1122	1048	160
	100	848	950	1350	1122	1207	159	1031	840	1600	1122	1048	161
	112	879	975	1400	1122	1207	159	1061	868	1650	1122	1048	161
	132	948	1034	1500	1122	1207	160	1082	886	1700	1122	1048	162
	160	1010	1085	1600	1122	1207	161	1140	940	1800	1122	1048	162
	180	1082	1149	1700	1122	1207	162	1211	1008	1900	1122	1048	163
710	90	907	1028	1450	1264	1382	229	1080	868	1700	1264	1200	232
	100	941	1055	1500	1264	1382	230	1112	897	1750	1264	1200	233
	112	972	1080	1550	1264	1382	230	1142	924	1800	1264	1200	233
	132	993	1095	1600	1264	1382	231	1162	941	1850	1264	1200	234
	160	1054	1144	1700	1264	1382	232	1220	994	1950	1264	1200	235
	180	1126	1207	1800	1264	1382	233	1290	1061	2050	1264	1200	236
200	1199	1272	1900	1264	1382	235	1313	1082	2100	1264	1200	237	

* The above weight does not include motor and drive unit as these will vary with supplier.

All Dimensions in mm.

OVERALL DIMENSION - BDB "T" SERIES

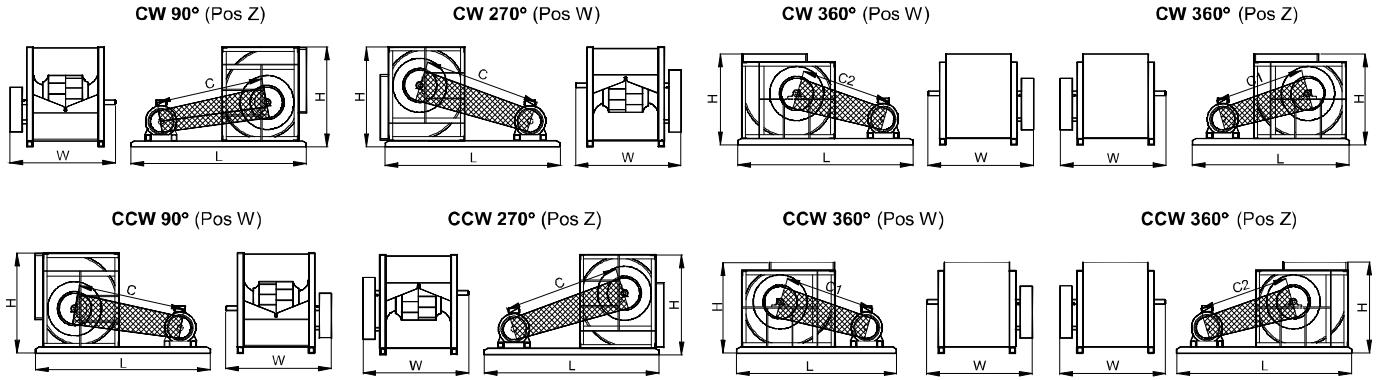

Model	Motor Frame Size	90°/ 270°						360°					
		C (90°)	C (270°)	L	W	H	* Wt (kg)	C1	C2	L	W	H	* Wt (kg)
315	100	542	571	900	662	618	47	614	509	1000	662	558	47
	112	568	594	940	662	618	47	638	533	1040	662	558	48
	132	625	645	1020	662	618	48	694	587	1120	662	558	48
	160	715	728	1140	662	618	48	791	684	1250	662	558	49
355	100	576	615	960	748	694	61	652	534	1060	748	618	61
	112	620	654	1020	748	694	61	695	575	1120	748	618	61
	132	676	704	1100	748	694	61	749	628	1200	748	618	62
	160	745	766	1200	748	694	62	816	693	1300	748	618	62
400	112	664	708	1080	802	776	75	750	619	1200	802	690	76
	132	719	756	1160	802	776	76	823	689	1300	802	690	77
	160	776	806	1250	802	776	76	888	752	1400	802	690	77
	180	854	877	1350	802	776	77	914	778	1450	802	690	77
450	112	707	763	1140	908	867	98	824	678	1300	908	766	99
	132	741	790	1200	908	867	98	846	699	1350	908	766	99
	160	856	894	1350	908	867	99	958	807	1500	908	766	100
	180	883	916	1400	908	867	99	983	832	1550	908	766	100
500	132	805	861	1300	986	968	134	899	740	1450	986	850	135
	160	870	917	1400	986	968	135	961	799	1550	986	850	136
	180	945	985	1500	986	968	136	1034	871	1650	986	850	137
	200	972	1008	1550	986	968	136	1109	944	1750	986	850	137
560	132	875	945	1400	1110	1080	175	968	792	1550	1110	942	177
	160	938	998	1500	1110	1080	176	1076	895	1700	1110	942	178
	180	1012	1064	1600	1110	1080	177	1100	917	1750	1110	942	178
	200	1038	1085	1650	1110	1080	177	1173	989	1850	1110	942	179
630	160	1010	1085	1600	1196	1207	217	1140	940	1800	1196	1048	218
	180	1082	1149	1700	1196	1207	218	1211	1008	1900	1196	1048	219
	200	1107	1169	1750	1196	1207	218	1235	1030	1950	1196	1048	220
	225	1177	1230	1850	1196	1207	219	1301	1095	2050	1196	1048	220
710	160	1054	1144	1700	1310	1382	284	1220	994	1950	1310	1200	287
	180	1126	1207	1800	1310	1382	285	1290	1061	2050	1310	1200	288
	200	1199	1272	1900	1310	1382	287	1313	1082	2100	1310	1200	289
	225	1268	1333	2000	1310	1382	288	1379	1146	2200	1310	1200	290
800	90	986	1130	1550	1418	1548	332	1187	955	1850	1418	1334	335
	100	1018	1156	1600	1418	1548	332	1218	983	1900	1418	1334	336
	112	1048	1180	1650	1418	1548	333	1247	1009	1950	1418	1334	337
	132	1115	1235	1750	1418	1548	334	1267	1024	2000	1418	1334	337
	160	1174	1283	1850	1418	1548	335	1370	1120	2150	1418	1334	339
	180	1197	1300	1900	1418	1548	336	1391	1139	2200	1418	1334	340
	200	1269	1362	2000	1418	1548	337	1461	1206	2300	1418	1334	341
	225	1336	1420	2100	1418	1548	338	1526	1268	2400	1418	1334	342
900	100	1140	1302	1750	1596	1728	405	1330	1067	2050	1596	1488	408
	112	1169	1325	1800	1596	1728	405	1358	1092	2100	1596	1488	409
	132	1189	1338	1850	1596	1728	406	1421	1148	2200	1596	1488	410
	160	1293	1425	2000	1596	1728	408	1476	1197	2300	1596	1488	411
	180	1315	1441	2050	1596	1728	408	1543	1260	2400	1596	1488	413
	200	1385	1501	2150	1596	1728	410	1564	1278	2450	1596	1488	413
	225	1451	1557	2250	1596	1728	411	1627	1338	2550	1596	1488	414
	250	1518	1615	2350	1596	1728	412	1692	1399	2650	1596	1488	416

* The above weight does not include motor and drive unit as these will vary with supplier.

All Dimensions in mm.

OVERALL DIMENSION - BDB "T" SERIES

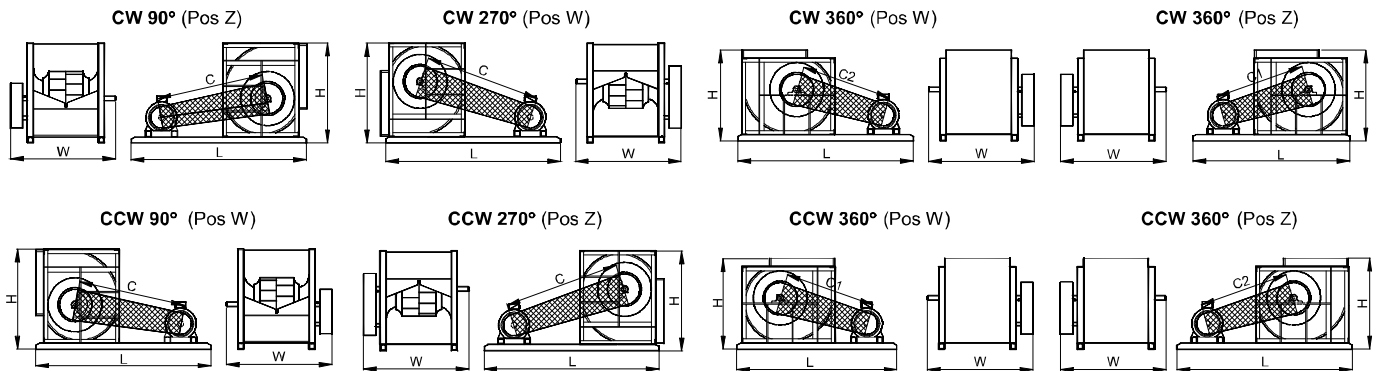

Model	Motor Frame Size	90° / 270°						360°					
		C (90°)	C (270°)	L	W	H	* Wt (kg)	C1	C2	L	W	H	* Wt (kg)
1000	100	1212	1401	1850	1754	1890	513	1486	1198	2250	1754	1620	518
	112	1241	1423	1900	1754	1890	514	1514	1222	2300	1754	1620	519
	132	1305	1475	2000	1754	1890	515	1532	1236	2350	1754	1620	520
	160	1361	1518	2100	1754	1890	517	1586	1282	2450	1754	1620	521
	180	1429	1575	2200	1754	1890	518	1651	1343	2550	1754	1620	522
	200	1451	1591	2250	1754	1890	518	1672	1360	2600	1754	1620	523
	225	1515	1644	2350	1754	1890	520	1734	1418	2700	1754	1620	524
	250	1581	1700	2450	1754	1890	521	1797	1477	2800	1754	1620	525
1120	112	1404	1603	2100	1830	2158	785	1676	1342	2500	1830	1850	795
	132	1423	1615	2150	1830	2158	786	1695	1356	2550	1830	1850	797
	160	1479	1658	2250	1830	2158	789	1749	1403	2650	1830	1850	799
	180	1547	1715	2350	1830	2158	791	1815	1464	2750	1830	1850	802
	200	1568	1730	2400	1830	2158	793	1836	1482	2800	1830	1850	803
	225	1632	1783	2500	1830	2158	795	1898	1539	2900	1830	1850	806
	250	1697	1837	2600	1830	2158	798	1961	1599	3000	1830	1850	809
	280	1806	1932	2750	1830	2158	802	2067	1700	3150	1830	1850	813
1250	132	1564	1790	2350	2005	2435	1160	1873	1491	2800	2005	2080	1182
	160	1619	1831	2450	2005	2435	1165	1926	1537	2900	2005	2080	1187
	180	1687	1886	2550	2005	2435	1170	1992	1596	3000	2005	2080	1191
	200	1708	1901	2600	2005	2435	1172	2058	1657	3100	2005	2080	1196
	225	1771	1952	2700	2005	2435	1177	2120	1714	3200	2005	2080	1201
	250	1835	2005	2800	2005	2435	1182	2182	1772	3300	2005	2080	1206
	280	1943	2097	2950	2005	2435	1189	2240	1825	3400	2005	2080	1211
1400	132	1733	1995	2600	2290	2718	1580	2084	1661	3100	2290	2320	1604
	160	1786	2035	2700	2290	2718	1585	2137	1707	3200	2290	2320	1609
	180	1805	2047	2750	2290	2718	1587	2202	1765	3330	2290	2320	1614
	200	1872	2101	2850	2290	2718	1592	2222	1782	3350	2290	2320	1616
	225	1933	2150	2950	2290	2718	1597	2282	1836	3450	2290	2320	1621
	250	1995	2201	3050	2290	2718	1602	2343	1893	3550	2290	2320	1626
	280	2053	2247	3150	2290	2718	1607	2447	1990	3700	2290	2320	1633
	315	2153	2331	3300	2290	2718	1614	2498	2037	3800	2290	2320	1638

* The above weight does not include motor and drive unit as these will vary with supplier.

All Dimensions in mm.

OVERALL DIMENSION - BDB "X" SERIES

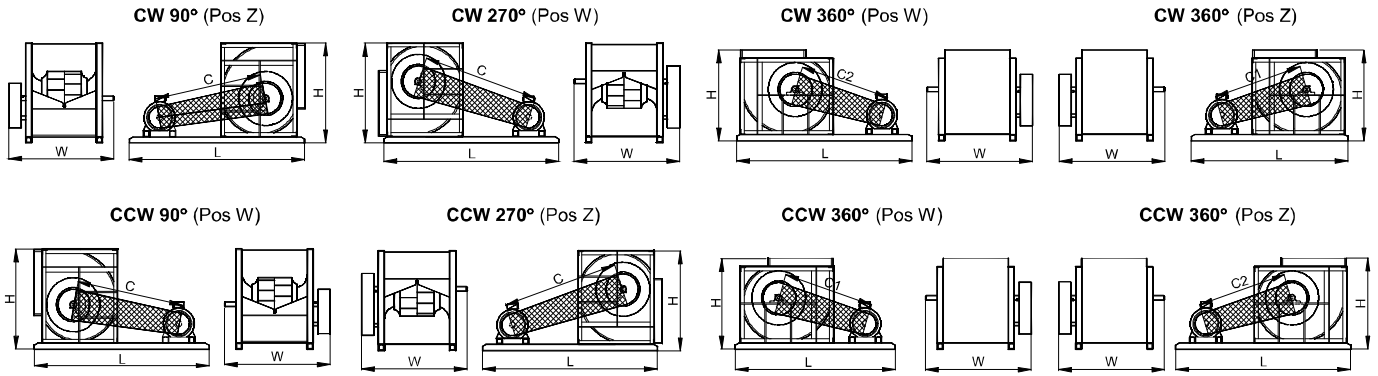

Model	Motor Frame Size	90°/ 270°						360°					
		C (90°)	C (270°)	L	W	H	* Wt (kg)	C1	C2	L	W	H	* Wt (kg)
315	132	625	645	1020	762	618	57	694	587	1120	762	558	57
	160	715	728	1140	762	618	57	791	684	1250	762	558	58
	180	754	764	1200	762	618	57	819	712	1300	762	558	58
	200	834	840	1300	762	618	58	898	790	1400	762	558	58
355	132	676	704	1100	852	694	73	749	628	1200	852	618	74
	160	745	766	1200	852	694	74	816	693	1300	852	618	74
	180	823	839	1300	852	694	74	892	769	1400	852	618	75
	200	852	865	1350	852	694	75	920	797	1450	852	618	75
400	160	776	806	1250	906	776	91	888	752	1400	906	690	92
	180	854	877	1350	906	776	92	914	778	1450	906	690	92
	200	882	902	1400	906	776	92	990	853	1550	906	690	93
	225	956	970	1500	906	776	93	1062	925	1650	906	690	93
450	160	856	894	1350	976	867	104	958	807	1500	976	766	105
	180	883	916	1400	976	867	104	983	832	1550	976	766	105
	200	960	987	1500	976	867	105	1059	906	1650	976	766	106
	225	1032	1055	1600	976	867	105	1130	976	1750	976	766	106
500	180	945	985	1500	1096	968	142	1034	871	1650	1096	850	143
	200	972	1008	1550	1096	968	142	1109	944	1750	1096	850	143
	225	1044	1073	1650	1096	968	143	1179	1013	1850	1096	850	144
	250	1117	1140	1750	1096	968	143	1250	1083	1950	1096	850	145
560	180	1012	1064	1600	1168	1080	185	1100	917	1750	1168	942	186
	200	1038	1085	1650	1168	1080	185	1173	989	1850	1168	942	187
	225	1109	1149	1750	1168	1080	186	1242	1056	1950	1168	942	188
	250	1180	1214	1850	1168	1080	187	1312	1124	2050	1168	942	189
630	200	1107	1169	1750	1316	1207	233	1235	1030	1950	1316	1048	235
	225	1177	1230	1850	1316	1207	234	1301	1095	2050	1316	1048	235
	250	1247	1294	1950	1316	1207	235	1370	1161	2150	1316	1048	236
	280	1362	1401	2100	1316	1207	236	1483	1273	2300	1316	1048	237
710	200	1199	1272	1900	1420	1382	307	1313	1082	2100	1420	1200	309
	225	1268	1333	2000	1420	1382	308	1379	1146	2200	1420	1200	310
	250	1338	1395	2100	1420	1382	309	1447	1211	2300	1420	1200	311
	280	1403	1453	2200	1420	1382	310	1559	1321	2450	1420	1200	313
800	160	1168	1273	1850	1528	1568	378	1363	1112	2150	1528	1354	384
	180	1191	1290	1900	1528	1568	379	1385	1132	2200	1528	1354	385
	200	1264	1353	2000	1528	1568	381	1455	1199	2300	1528	1354	387
	225	1331	1412	2100	1528	1568	383	1521	1261	2400	1528	1354	389
	250	1400	1472	2200	1528	1568	385	1587	1326	2500	1528	1354	391
	280	1464	1528	2300	1528	1568	387	1649	1386	2600	1528	1354	392
900	180	1308	1431	2050	1690	1748	458	1536	1251	2400	1690	1508	465
	200	1380	1492	2150	1690	1748	460	1558	1270	2450	1690	1508	466
	225	1446	1548	2250	1690	1748	462	1621	1330	2550	1690	1508	468
	250	1513	1607	2350	1690	1748	464	1686	1392	2650	1690	1508	470
	280	1576	1660	2450	1690	1748	466	1795	1497	2800	1690	1508	472
	315	1683	1757	2600	1690	1748	469	1850	1551	2900	1690	1508	474
1000	200	1445	1581	2250	1875	1910	580	1665	1352	2600	1875	1640	586
	225	1510	1635	2350	1875	1910	582	1727	1410	2700	1875	1640	588
	250	1576	1691	2450	1875	1910	583	1790	1469	2800	1875	1640	590
	280	1686	1789	2600	1875	1910	586	1897	1572	2950	1875	1640	593
	315	1792	1882	2750	1875	1910	589	2000	1671	3100	1875	1640	596

* The above weight does not include motor and drive unit as these will vary with supplier.

All Dimensions in mm.

OVERALL DIMENSION - BDB "X" SERIES

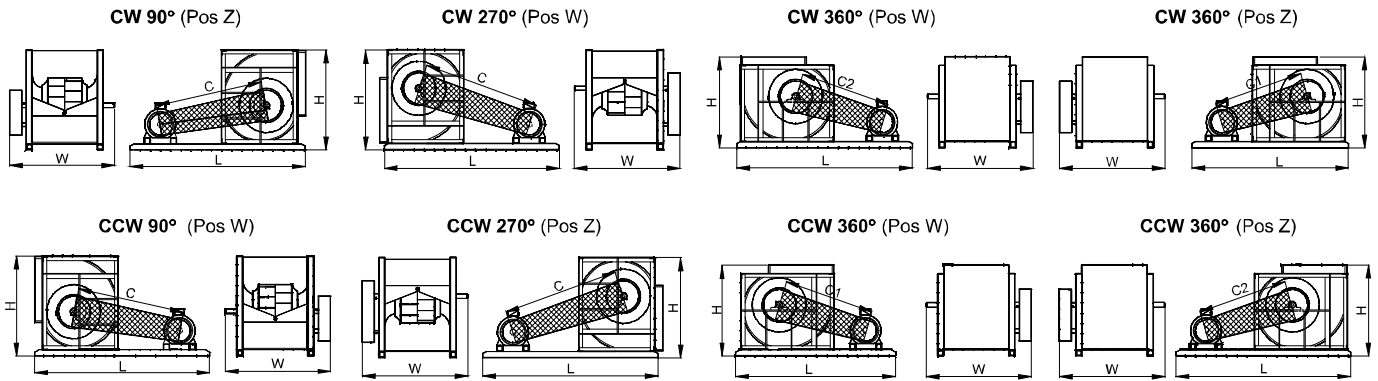

Model	Motor Frame Size	90° / 270°						360°					
		C (90°)	C (270°)	L	W	H	* Wt (kg)	C1	C2	L	W	H	* Wt (kg)
1120	250	1746	1882	2650	1946	2158	867	1961	1599	3000	1946	1850	877
	280	1806	1932	2750	1946	2158	870	2067	1700	3150	1946	1850	881
	315	1911	2024	2900	1946	2158	874	2169	1798	3300	1946	1850	885
	355	2012	2112	3050	1946	2158	878	2266	1892	3450	1946	1850	889
1250	250	1883	2049	2850	2065	2435	1281	2182	1772	3300	2065	2080	1303
	280	1943	2097	2950	2065	2435	1286	2240	1825	3400	2065	2080	1308
	315	2046	2186	3100	2065	2435	1293	2340	1921	3550	2065	2080	1315
	355	2145	2272	3250	2065	2435	1300	2436	2013	3700	2065	2080	1322
1400	280	2053	2247	3150	2325	2718	1675	2447	1990	3700	2325	2320	1701
	315	2153	2331	3300	2325	2718	1682	2498	2037	3800	2325	2320	1706
	355	2250	2413	3450	2325	2718	1689	2640	2173	4000	2325	2320	1715

* The above weight does not include motor and drive unit as these will vary with supplier.

All Dimensions in mm.

* Please consult Kruger for the overall dimension of Fan BDB 1600, 1800 & 2000.

Overall Fan Assembly Dimensions with Coupling Rotation 90°

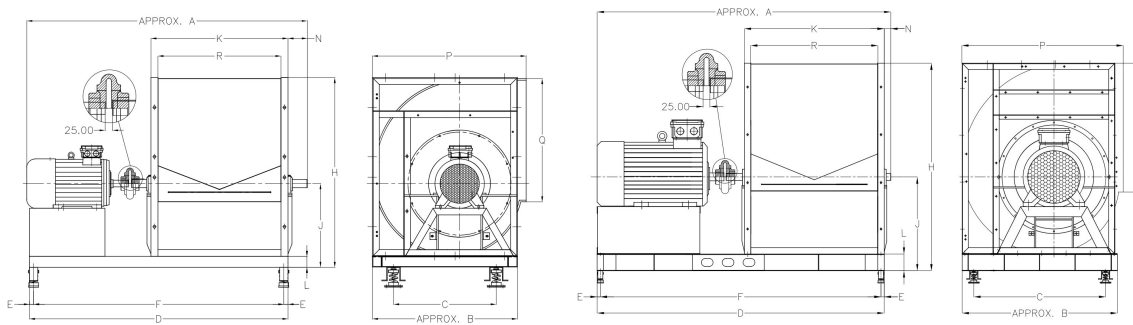

Model	Type	Rotation	FS	A	B	C	D	E	F	H	J	K	L	N	P	Q	Weight(Kg.)
315	C	90	100	1010	480	320	950	27.5	895	618	278	464	40	68	518	404	47
315	C	90	112	1030	480	320	950	27.5	895	618	278	464	40	68	518	404	48
315	C	90	132	1140	480	320	1030	27.5	975	618	278	464	40	68	518	404	50
355	C	90	100	1080	548	388	1000	27.5	945	694	311	532	40	70	578	452	63
355	C	90	112	1100	548	388	1000	27.5	945	694	311	532	40	70	578	452	64
355	C	90	132	1210	548	388	1130	27.5	1075	694	311	532	40	70	578	452	67
400	C	90	100	1140	612	452	1050	27.5	995	776	344	586	40	70	650	506	69
400	C	90	112	1160	612	452	1050	27.5	995	776	344	586	40	70	650	506	70
400	C	90	132	1270	612	452	1180	27.5	1125	776	344	586	40	70	650	506	73
400	C	90	160	1410	612	452	1250	27.5	1195	776	344	586	40	70	650	506	76
400	C	90	180	1470	612	452	1300	27.5	1245	776	344	586	40	70	650	506	77
400	C	90	200	1520	612	452	1400	27.5	1345	776	344	586	40	70	650	506	79
450	C	90	112	1240	681	521	1150	27.5	1095	867	381	648	40	83	726	568	89
450	C	90	132	1350	681	521	1280	27.5	1225	867	381	648	40	83	726	568	93
450	C	90	160	1490	681	521	1350	27.5	1295	867	381	648	40	83	726	568	96
450	C	90	180	1560	681	521	1350	27.5	1295	867	381	648	40	83	726	568	97
450	C	90	200	1610	681	521	1450	27.5	1395	867	381	648	40	83	726	568	99
500	C	90	132	1460	750	550	1330	27.5	1275	968	430	718	50	103	800	638	118
500	C	90	160	1600	750	550	1450	27.5	1395	968	430	718	50	103	800	638	123
500	C	90	180	1670	750	550	1450	27.5	1395	968	430	718	50	103	800	638	124
500	C	90	200	1720	750	550	1550	27.5	1495	968	430	718	50	103	800	638	126
500	C	90	225	1800	750	550	1600	27.5	1545	968	430	718	50	103	800	638	128
560	C	90	160	1680	844	644	1550	27.5	1495	1080	477	814	50	93	892	714	162
560	C	90	180	1750	844	644	1550	27.5	1495	1080	477	814	50	93	892	714	164
560	C	90	200	1800	844	644	1650	27.5	1595	1080	477	814	50	93	892	714	167
560	C	90	225	1880	844	644	1700	27.5	1645	1080	477	814	50	93	892	714	170
560	C	90	250	1960	844	644	1780	27.5	1725	1080	477	814	50	93	892	714	174
630	C	90	160	1770	945	745	1650	27.5	1595	1207	528	900	50	96	998	800	198
630	C	90	180	1840	945	745	1650	27.5	1595	1207	528	900	50	96	998	800	201
630	C	90	200	1890	945	745	1750	27.5	1695	1207	528	900	50	96	998	800	204
630	C	90	225	1970	945	745	1800	27.5	1745	1207	528	900	50	96	998	800	207
630	C	90	250	2050	945	745	1930	27.5	1875	1207	528	900	50	96	998	800	211
710	C	90	180	1980	1057	777	1800	37.5	1725	1382	617	998	80	118	1120	898	314
710	C	90	200	2030	1057	777	1900	37.5	1825	1382	617	998	80	118	1120	898	318
710	C	90	225	2110	1057	777	1900	37.5	1825	1382	617	998	80	118	1120	898	322
710	C	90	250	2190	1057	777	2030	37.5	1955	1382	617	998	80	118	1120	898	329
710	C	90	280	2270	1057	777	2100	37.5	2025	1382	617	998	80	118	1120	898	333
450	T	90	112	1310	681	521	1150	27.5	1095	867	399	648	40	115	726	568	124
450	T	90	132	1420	681	521	1280	27.5	1225	867	399	648	40	115	726	568	128
450	T	90	160	1560	681	521	1350	27.5	1295	867	399	648	40	115	726	568	131
450	T	90	180	1620	681	521	1350	27.5	1295	867	399	648	40	115	726	568	132
450	T	90	200	1670	681	521	1450	27.5	1395	867	399	648	40	115	726	568	134
500	T	90	132	1500	750	550	1330	27.5	1275	968	430	718	50	119	800	638	153
500	T	90	160	1640	750	550	1450	27.5	1395	968	430	718	50	119	800	638	158
500	T	90	180	1700	750	550	1450	27.5	1395	968	430	718	50	119	800	638	159
500	T	90	200	1750	750	550	1550	27.5	1495	968	430	718	50	119	800	638	161
500	T	90	225	1830	750	550	1600	27.5	1545	968	430	718	50	119	800	638	163
560	T	90	160	1760	844	644	1550	27.5	1495	1080	477	814	50	133	892	714	210
560	T	90	180	1830	844	644	1550	27.5	1495	1080	477	814	50	133	892	714	212
560	T	90	200	1880	844	644	1650	27.5	1595	1080	477	814	50	133	892	714	215
560	T	90	225	1960	844	644	1700	27.5	1645	1080	477	814	50	133	892	714	218
560	T	90	250	2040	844	644	1780	27.5	1725	1080	477	814	50	133	892	714	222
630	T	90	160	1850	945	745	1650	27.5	1595	1207	528	900	50	133	998	800	258
630	T	90	180	1910	945	745	1650	27.5	1595	1207	528	900	50	133	998	800	261
630	T	90	200	1960	945	745	1750	27.5	1695	1207	528	900	50	133	998	800	264
630	T	90	225	2040	945	745	1800	27.5	1745	1207	528	900	50	133	998	800	267
630	T	90	250	2130	945	745	1930	27.5	1875	1207	528	900	50	133	998	800	271
710	T	90	180	2030	1057	777	1800	37.5	1725	1382	617	998	80	141	1120	898	374
710	T	90	200	2080	1057	777	1900	37.5	1825	1382	617	998	80	141	1120	898	378
710	T	90	225	2160	1057	777	1900	37.5	1825	1382	617	998	80	141	1120	898	382
710	T	90	250	2240	1057	777	2030	37.5	1955	1382	617	998	80	141	1120	898	389
710	T	90	280	2320	1057	777	2100	37.5	2025	1382	617	998	80	141	1120	898	393
800	T	90	180	2130	1180	900	1900	37.5	1825	1548	686	1106	80	141	1254	1006	439
800	T	90	200	2180	1180	900	2000	37.5	1925	1548	686	1106	80	141	1254	1006	444
800	T	90	225	2260	1180	900	2000	37.5	1925	1548	686	1106	80	141	1254	1006	448
800	T	90	250	2350	1180	900	2130	37.5	2055	1548	686	1106	80	141	1254	1006	458
800	T	90	280	2420	1180	900	2250	37.5	2175	1548	686	1106	80	141	1254	1006	464
800	T	90	315	2700	1180	900	2400	37.5	2325	1548	686	1106	80	141	1254	1006	485

Operational Limits - "BDB"

		315	355	400	450	500	560	630	710	800	900	1000	1120	1250	1400	1600	1800	2000	
Maximum Absorbed Power	S-C	kW	4	5	6	8	10	12	14	18									
	T	kW	8	11	14	18	20	25	30	40	22	30	35	45	50	70			
	X	kW	16	22	28	35	45	50	60	80	50	60	80	100	120	180	250	300	
	Z	kW									100	120	160	180	200	250	400	600	
S2-C2	kW	5	6.5	6.5	7.5	7.5													
	T2	kW		15	15	18	22	22	25										
Maximum Fan Speed	S-C	rpm	3100	2700	2500	2200	1900	1700	1500	1350									
	T	rpm	4100	3500	3200	2900	2500	2200	2000	1800	1200	1050	1000	850	780	680			
	X	rpm	5100	4500	4100	3600	3200	2800	2500	2200	1600	1400	1300	1100	1000	900	750	600	
	Z	rpm									2000	1750	1600	1400	1250	1100	950	850	
S2-C2	rpm	2400	2200	1800	1600	1200													
	T2	rpm		2800	2400	2200	2000	1550	1300										
Temperature Range / Min. -20°C	S-C	Max.°C	85	85	85	85	85	85	85	85									
	T-X	Max.°C	100	100	100	100	100	100	100	100	100	100	100	100	100	100	100	100	
	S2-C2	Max.°C	85	85	85	85	85												
	T2	Max.°C		100	100	100	100	100	100										
Diameter	mm	315	355	400	450	500	560	630	710	800	900	1000	1120	1250	1400	1600	1800	2000	
	kg																		
Wheel Weight	kgm²	0.17	0.30	0.44	0.82	1.42	2.19	3.53	6.6	11.1	17.5	30	52	87	137	285	512	797	
	J = PD²/4																		
Fan weight	S	kg	26	37	42	58	74	95	118	174									
	C	kg	27	41	45	62	81	110	141	199									
	T	kg	40	53	67	89	118	158	197	251	299	368	474	687	967	1362			
	X	kg	49	65	82	94	124	166	212	271	323	397	512	755	1064	1430	2300	3150	3800
	Z	kg									485	595	768	1132	1383	1859	2500	3400	4100
	S2	kg	46	66	76	103	129												
C2	kg	53	76	91	117	148													
	T2	kg		106	132	147	182	235	296										



Centrifugal Fan Ordering Information

Fan Details				
■ Fan type		<input type="checkbox"/> DIDW	<input type="checkbox"/> SISW	
■ Impeller type		<input type="checkbox"/> Forward Curved <input type="checkbox"/> Backward Curved <input type="checkbox"/> Others : _____ (Please State)		
■ Model & size e.g. BDB 560 C		□ Model : _____ (If known)		
■ Drive type - belt, direct, coupling (if differ from standard)		<input type="checkbox"/> Belt <input type="checkbox"/> Direct <input type="checkbox"/> Coupling <input type="checkbox"/> Others : _____ (Please State)		
■ Arrangement (1 & 3 for bare shaft fan; 4, 8 & 12 for complete with drive system)		<input type="checkbox"/> Bare fan <input type="checkbox"/> Complete with drive system		
■ Rotation & Discharge e.g. CCW 270		<input type="checkbox"/> CW <input type="checkbox"/> CCW <input type="checkbox"/> 90 <input type="checkbox"/> 180 <input type="checkbox"/> 270 <input type="checkbox"/> 360		
■ Motor position (refer to diagram) e.g. W		<input type="checkbox"/> W <input type="checkbox"/> X <input type="checkbox"/> Y <input type="checkbox"/> Z		
■ Air Flow Rate		Q : _____ <input type="checkbox"/> L/S <input type="checkbox"/> m ³ /h <input type="checkbox"/> m ³ /min <input type="checkbox"/> m ³ /s <input type="checkbox"/> cfm		
■ Pressure (static & total)		SP : _____ TP : _____ <input type="checkbox"/> Pa <input type="checkbox"/> mmH ₂ O <input type="checkbox"/> inWG		
■ Fan RPM (if specified)		Max. : _____ Min. : _____		
■ Noise level		<input type="checkbox"/> dB <input type="checkbox"/> dBA Lw : _____ Lp : _____ at Distance : _____ m <input type="checkbox"/> free field <input type="checkbox"/> room condition <input type="checkbox"/> corner / wall		
■ Ambient temperature		□ Temp. : _____ °C		
■ Air density, if differ from standard		<input type="checkbox"/> Density : _____ kg/m ³ <input type="checkbox"/> Altitude : _____ m		
Motor Details		Fittings Detail		
■ Power		■ Accessories <input type="checkbox"/> Inspection door <input type="checkbox"/> Drain plug <input type="checkbox"/> Flexible duct <input type="checkbox"/> Inlet vane control <input type="checkbox"/> Vibration Isolators: <input type="checkbox"/> Rubber <input type="checkbox"/> Spring <input type="checkbox"/> Floor-mount <input type="checkbox"/> Ceiling-hang <input type="checkbox"/> Silencers : <input type="checkbox"/> With pod <input type="checkbox"/> Without pod <input type="checkbox"/> Inlet <input type="checkbox"/> Outlet <input type="checkbox"/> Both inlet & outlet <input type="checkbox"/> Counter-flanges : <input type="checkbox"/> Flat <input type="checkbox"/> L-type <input type="checkbox"/> U-type <input type="checkbox"/> Inlet <input type="checkbox"/> Outlet		
□ kW : _____ □ HP : _____				
■ No. of Poles / RPM			<input type="checkbox"/> 2P <input type="checkbox"/> 4P <input type="checkbox"/> 6P <input type="checkbox"/> 8P <input type="checkbox"/> Others : _____ (pls state RPM)	
■ Voltage			<input type="checkbox"/> 220V <input type="checkbox"/> 415V <input type="checkbox"/> 380V <input type="checkbox"/> 440V <input type="checkbox"/> 400V <input type="checkbox"/> Others : _____	
■ Phase		<input type="checkbox"/> 1φ <input type="checkbox"/> 3φ		
■ Frequency		<input type="checkbox"/> 50 Hz <input type="checkbox"/> 60 Hz		
■ Frame size		Special Features		
□ IEC : _____ □ NEMA : _____ □ Others : _____		■ Other Requirements <input type="checkbox"/> Painting <input type="checkbox"/> Powder coating <input type="checkbox"/> Hot-dipped galvanizing <input type="checkbox"/> Spark-resistant <input type="checkbox"/> Corrosion-resistant <input type="checkbox"/> Heat-resistant, temp. _____ °C <input type="checkbox"/> Smoke Spill, Max. temp. _____ °C for _____ Hr		
■ Make, if specified				
□ Brand : _____ □ Mfr. : _____ □ Country : _____				

KRUGER GROUP (VENTILATION)

• THAILAND (Regional HQ)

KRUGER VENTILATION INDUSTRIES ASIA CO. LTD.

30/159 Moo 1, Sinsakorn Industrial Estate,
Chetsadawithi Road, Khok Kham Mueng, Samuthsakorn 74000, Thailand
Tel. +662 1054298 - Fax +662 0248256-9
Website: www.krugerfan.com

• CHINA (BEIJING)

BEIJING KRUGER VENTILATION CO. LTD

Level 7, A Block, Rising International Building, 29 JingHai San Road, BDA,
Beijing, P.R.China 100176
Tel. +86 10-67881366 - Fax +86 10-67880566
Email: krugertj@krugertj.com

• CHINA (SHANGHAI)

SHANGHAI KRUGER VENTILATION CO. LTD

No. 500 Yuanguo Road, Anting, Jiading,
Shanghai 201814 P.R. China
Tel. +86 21-69573266 - Fax +86 21-69573296
Email: shkruger@krugerchina.com

• CHINA (WUHAN)

WUHAN KRUGER VENTILATION CO. LTD

No. 805, Huian Ave, Dongxihu District, Wuhan, Hubei, P.R. China 430000
Tel. +86 27- 83248840/83060522/83097505
Fax +86 27- 83261886
Email: whkruger@krugerwh.com

• HONG KONG

KRUGER VENTILATION (HONG KONG) LIMITED

Fiat C, 9/F, Yeung Yiu Chung (No.8) Industrial Building,
20 Wang Hoi Road, Kowloon Bay, Kowloon, Hong Kong
Tel. +852 22469182 - Fax +852 22469187
Email: info@kruger.com.hk

• INDIA (NORTH)

KRUGER VENTILATION INDUSTRIES (NORTH INDIA) PVT LTD

Plot No. - 191, Sector - 59, Ballabgarh, Faridabad - 121 004, Haryana, India
Tel. +91-9958991660/9717449696
Fax. +91-1294135820
Email: sales.kni@krugerindia.com

• KOREA

NEOMATE CO. LTD

2-1010, Ace High Tech City B/D, 775 Gyeongin-ro,
Yeongdeungpo-gu, Seoul, Korea. Postal Code 07299
Tel. +82-2-2679-2052 - Fax. +82-2-2679-2174
Email: y7890@neomate.co.kr

• MYANMAR

KRUGER VENTILATION (MYANMAR) CO.LTD

Room No. F21, Thiri Yadanar Whole Sale Market, (Htawunbe)
Toe Chae Ward, North Okkalapa Township, Yangon.
Tel. +959 763141081/2/3
Email: htoon@krugermm.com

• SINGAPORE

KRUGER ENGINEERING PTE LTD

No. 10 Buroh Street #06-06, West Connect Building,
Singapore 627564
Tel. +65 68631191 - Fax +65 68631151
Email: mktg@krugerasia.com

• THAILAND

KRUGER VENTILATION IND. (THAILAND) CO. LTD

30/105 Moo 1, Sinsakorn Industrial Estate,
Chetsadawithi Road, Khok Kham Mueng, Samuthsakorn 74000, Thailand
Tel. +662 1050399 - Fax + 662 1050370-2
Email: mktg@kruger.co.th

• AUSTRALIA

S&P-KRUGER AUSTRALIA PTY LTD

2 Cunningham St, Moorebank N.S.W. 2170
Tel. +61 2-98227747
Fax. +61 2-98227757
Email: info@sandpkruiger.com.au

• CHINA (GUANGZHOU)

GUANGZHOU KRUGER VENTILATION CO. LTD

No. 9 Huahui Road, Huashan, Huadu,
Guangzhou, P.R. China 510880
Tel. +86 20-66356635 - Fax +86 20-86786001/86786500
Email: gzkruger@krugergz.com

• CHINA (TIANJIN)

TIANJIN KRUGER VENTILATION CO. LTD

No.168 Anyuan Road, Jingjin Science and Technology Park
Wuqing District, Tianjin, China
Tel. +86 22-22143480/3481 - Fax +86 22-22143482
Email: krugertj@krugertj.com

• DUBAI

KRUGER VENTILATION INDUSTRIES, GULF BRANCH

Jebel Ali Free Zone Area (JAFZA) P.O. Box No. 262949, Dubai, UAE
Tel. +971 4 8819188/8832017
Fax. +971 4 8832018
Email: johncs@krugerasia.com

• INDIA

KRUGER VENTILATION INDUSTRIES (INDIA) PVT LTD

Kruger Centre, Mumbai-Nasik Highway,
Kalamgaon, Shahapur, Thane 421601, Maharashtra, India
Tel. +91 9960558899/9975577211 - Fax +91 2527 240075
Email: sales@krugerindia.com

• INDONESIA

P.T. KRUGER VENTILATION INDONESIA

JL. Teuku Umar No.20,
Karawaci - Tangerang 15115, Indonesia
Tel. +62 21-5512288/5513557 - Fax +62 21-5513502
Email: mktg@krugerindo.co.id

• MALAYSIA

KRUVENT INDUSTRIES (M) SDN BHD

Lot 850, Jalan Subang 7, Taman Perindustrian Subang,
47500, Subang Jaya, Selangor D.E.
Tel. +603 80743399 - Fax +603 80743388
Email: mktg@kruger.com.my

• PHILIPPINES

KRUGER M&E INDUSTRIES CORPORATION

FAPI Compound, E. Rodriguez Ave.
Tunasan, Muntinlupa City 1773, Philippines
Tel. +63 2-8622892/4/6/7, 5534059 - Fax +63 2-8622891
Email: mktg@krugerph.net

• TAIPEI

KRUGER VENTILATION (TAIWAN) CO. LTD

No. 157, Ping-an Rd, Hengfeng Village,
Dayuan Shiang Taoyuan County 337, Taiwan
Tel. +886 3-3859119 - Fax +886 3-3859118
Email: sales@krugertwn.com.tw

• VIETNAM

KRUGER VENTILATION INDUSTRIES (VIETNAM) CO. LTD

Lot A7. 2-4, C2 Road, Thanh Thanh Cong IZ,
Trang Bang Dist. Tay Ninh Province, Vietnam
Tel. +84-276 3585200/01/02 - Fax +84-276 3585199
Email: mktg@krugervn.com

Kruger Ventilation Industries Asia Co., Ltd

30/159 Moo 1, Sinsakorn Industrial Estate
Chetsadawithi Road, Khok Kham Mueng,
Samuthsakorn 74000, Thailand
Tel. +662 1054298 - Fax. +662 0248256-9
Website: www.krugerfan.com
CNo. - CAT008.E6 June 2022

A member of
Soler&Palau  Ventilation Group