

## UPBLAST SPUN ALUMINUM ROOF, WALL & KITCHEN VENTILATORS



Model ATB



Model AWX

**MODELS:** ATB / ATBR / AWX / AWXR





Model AWXR

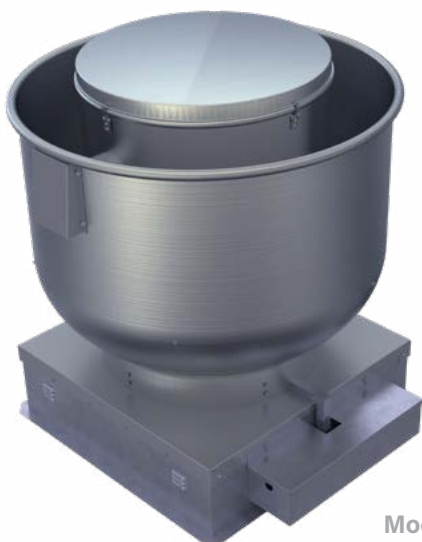

Model ATBR

## Overview

### Roof & Wall Exhausters

Aerovent's line of quiet, efficient and economical spun aluminum centrifugal power roof and wall exhausters are designed to offer value and long-lasting service in a wide variety of commercial and industrial ventilating applications.

#### Typical Applications Include

Agriculture, Automotive, Boilers, Brick, Car Wash, Commercial Plan & Spec, Composting, Ethanol, Food & Beverage, Foundry, General Manufacturing, Glass, HVAC, Institutional & Hospitality, Metal & Minerals, Microchip, OEM, Pharmaceutical, Power Generation, Recycling, Textile, Transportation

#### Configurations

Upblast and Wall Mounted, Belt Driven

#### Impeller Types

Backward Inclined Centrifugal

#### Optional Construction

Special Coatings, Spark Resistant, UL 705, UL 705 Supplement SC (formerly UL 762)

#### Certifications

AMCA Sound/Air and FEI, UL 705 Listed for Electrical, cULus Listed for Power Ventilators for Restaurant Exhaust Applications



ATB, ATBR, AWX and AWXR models are cULus 705 listed for electrical, File No. E158680.



ATBR and AWXR models are cULus 705 Supplement SC (formerly cULus 762) listed for the exhaust of grease-laden air, File No. E158680.



Aerovent, a Twin City Fan Company, certifies that the ATB, ATBR, AWX and AWXR Series shown herein are licensed to bear the AMCA Seal. Certified performance data may be found in Aerovent's Fan Selector software.



Scan the QR code to search Aerovent's AMCA-certified products.

## Energy Regulations

Aerovent supports energy efficiency regulations enacted by the U.S. Department of Energy (DOE) and specific states. The selection and application of fan products is a significant part of these regulations. Engineers and specifiers must understand how to apply Aerovent products to their specific applications to meet applicable DOE and state regulatory requirements. Aerovent has made significant investments in product testing and development to provide efficient products. Developments in Aerovent's Fan Selector software are in place to aid your decision in product selection to assist with meeting the efficiency requirements as stipulated in the applicable regulations.



For complete product performance, drawings and available accessories, download our Fan Selector software at [aerovent.com](http://aerovent.com).

## Overview Models

### General Exhaust

#### ATB (Belt Driven)

24.80" to 49.21" impeller diameters  
Airflow to 29,100 CFM  
Static pressure to 3.25" w.g.



#### AWX (Belt Driven)

24.80" to 31.5" impeller diameters  
Airflow to 15,100 CFM  
Static pressure to 3.25" w.g.



### Kitchen & Restaurant Fans

#### ATBR (Belt Driven)

24.80" to 39.37" impeller diameters  
Airflow to 20,700 CFM  
Static pressure to 3.25" w.g.



#### AWXR (Belt Driven)

24.80" to 31.5" impeller diameters  
Airflow to 15,100 CFM  
Static pressure to 3.25" w.g.

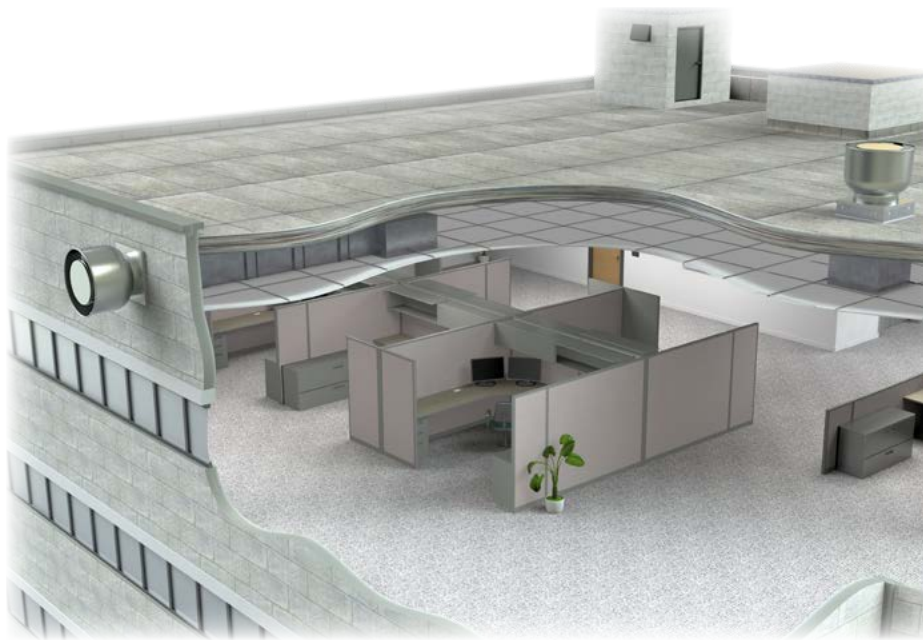

General HVAC  
Roof and Wall Exhaust



Hotel and Restaurant Exhaust



## General Exhaust



### Model ATB

Model ATB is designed for roof mounted exhaust of clean air in applications where it is desirable to move the exhausted air up and away from the building, and where re-entry into the building supply air is possible.

### Model ATB (Belt Driven)

- > Available in ten sizes from size 210 to 480, including five high-pressure models
- > Airflow to 29,100 CFM
- > Static pressure to 3.25" w.g.
- > AMCA Licensed for Sound, Air and Fan Energy Index
- > UL 705 listed



### Model AWX

Model AWX are designed for general exhaust of clean air in a wall-mounted, horizontal configuration. The wall-mounted fans are supplied with a heavy-duty 4" wall-mounting bracket. A 10" wall-mounting bracket is supplied when a gravity or motorized damper is utilized.

### Model AWX (Belt Driven)

- > Available in six sizes from size 210 to 300, including four high-pressure models
- > Airflow to 15,100 CFM
- > Static pressure to 3.25" w.g.
- > AMCA Licensed for Sound, Air and Fan Energy Index
- > UL 705 listed

## Kitchen Exhaust

### Model ATBR

Model ATBR is similar to the ATB, but is specifically designed for exhausting grease-laden air from kitchens, restaurants, cooking and dishwasher hoods. Aerovent also offers grease collection systems for kitchen and restaurant use.

### Model ATBR (Belt Driven)

- > Available in eight sizes from size 210 to 360, including five high-pressure models
- > Airflow to 20,700 CFM
- > Static pressure to 3.25" w.g.
- > AMCA Licensed for Sound, Air and Fan Energy Index
- > UL 705 Supplement SC (formerly UL 762) listed for Grease-Laden Air



### Model AWXR

Model AWXR is designed for general exhaust of clean air in a wall-mounted, horizontal configuration.

### Model AWXR (Belt Driven)

- > Available in six sizes from size 210 to 300, including four high-pressure models
- > Airflow to 15,100 CFM
- > Static pressure to 3.25" w.g.
- > AMCA Licensed for Sound, Air and Fan Energy Index
- > UL 705 Supplement SC (formerly UL 762) listed for Grease-Laden Air





**Motor Cover** - Provides complete protection for the motor and drive assembly, while allowing quick access to these components without the need for tools.

**Motor Housing** - Constructed from heavy-gauge aluminum for durability and appearance. Includes conduit tubing for routing electrical wiring through the outer shroud and into the motor compartment.

**Motors** - ODP, TEFC and explosion proof, single and three phase motors are carefully matched to the fan load.

**Vibration Isolation** - Motor and drive assembly is completely isolated from the fan supports by rubber isolators to reduce transmission of noise and vibration.

**Drive (Belt Driven)** - Adjustable pitch V-belt drives with cast iron sheaves and heat resistant belts are selected at 150% of the driven motor horsepower.

**Bearings (Belt Driven)** - Heavy-duty re-greaseable pillow block ball bearings are specifically designed for air handling applications to provide an average life (L-50) of 500,000 hours or more at maximum cataloged operating speeds.

**Shaft (Belt Driven)** - Precision ground and polished with a first critical speed of at least 125% of the fan's maximum operating speed.

**Galvanized Bird Screen** - Protects the impeller, inlet and internal components from entry of birds. Optional on Model ATBR, standard on wall-mounted models.

**Impeller** - Quiet and efficient non-overloading, heavy-gauge impellers with backwardly curved blades are precisely matched to a deep spun venturi. All impellers are statically and dynamically balanced to ensure smooth and quiet operation.

**Fan Shroud** - Heavy-gauge spun aluminum with rolled bead edge provides rigidity. Motor cooling tubes are incorporated into the exterior of shroud to draw outside air into the motor and drive compartment.

**Curb Cap** - One-piece curb cap/inlet venturi assembly provides protection from weather. Pre-punched mounting holes provide easy and accurate attachment to the roof curb.

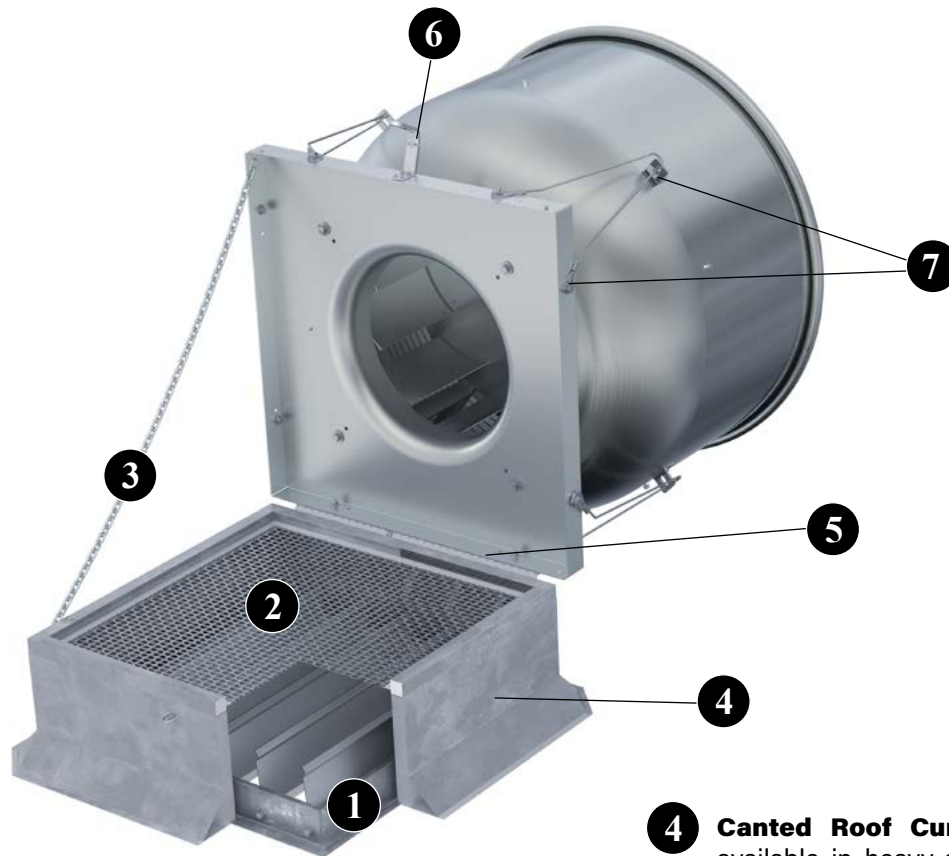

- 1 Backdraft Damper (ATB)** with automatic or motorized operation, feature a felt seal on the edge of the damper blades for quiet operation. Damper frames are constructed of galvanized steel and blades are constructed of aluminum.

Motorized dampers are recommended for low CFM applications to assure unrestricted airflow. Motorized dampers are available with 115, 208, 230, 460, 575 or 24 volt service. End switches are available. When a motorized damper option is selected a 12" (or greater) high roof curb is required.

**(AWX)** with automatic or motorized operation, feature a vinyl seal on the edge of the damper blades for quiet operation. Damper frames are constructed of galvanized steel and blades are constructed of aluminum.

Motorized dampers are available with 115, 208, 230, 460 or 575 volt service, and have end switches as standard.

- 2 Insect Screen** An aluminum screen, placed between the fan base and the roof curb, provides protection from entry of insects into impeller, inlet and interior of building. Available for Models ATB and AWX only.
- 3 Retaining Chain** is available in conjunction with the curb hinge arrangement to stabilize the unit and to prevent damage from occurring to the unit while servicing and cleaning.

- 4 Canted Roof Curb** Prefabricated roof curbs are available in heavy-duty galvanized steel or aluminum construction, in heights of 8", 12" or 18". The canted curb is provided with a factory installed wood nailer and damper tray. Curbs are provided with 1.5" of insulation as standard and feature continuously-welded seams for added rigidity and moisture protection. Prefabricated curbs are also available in self-flashing, pitched and peak models. Refer to Catalog PRC-110 for complete details on roof curb options. Minimum 12" high curbs are recommended for use with motorized dampers.

- 5 Curb Hinge** The curb hinge arrangement provides easy access to the exhaust fan, backdraft damper and duct for servicing and cleaning. The curb hinge is of the piano type, running the entire length of the fan's curb cap. The curb hinge option ships loose and is designed for use with a standard canted curb only (1.5" less than fan base). This option cannot be used with self-flashing curbs. Available as an option on Models ATB and ATBR.

- 6 Security Hasp** is available in conjunction with the curb hinge arrangement to prevent removal of the unit from the roof curb and prevent entrance into the building through the roof's ductwork.

- 7 Tie-Down Brackets** A quantity of four brackets are mounted to the fan shroud to allow the fan to be secured to the roof in areas where high winds are a concern. Guy wires are supplied and installed by others.

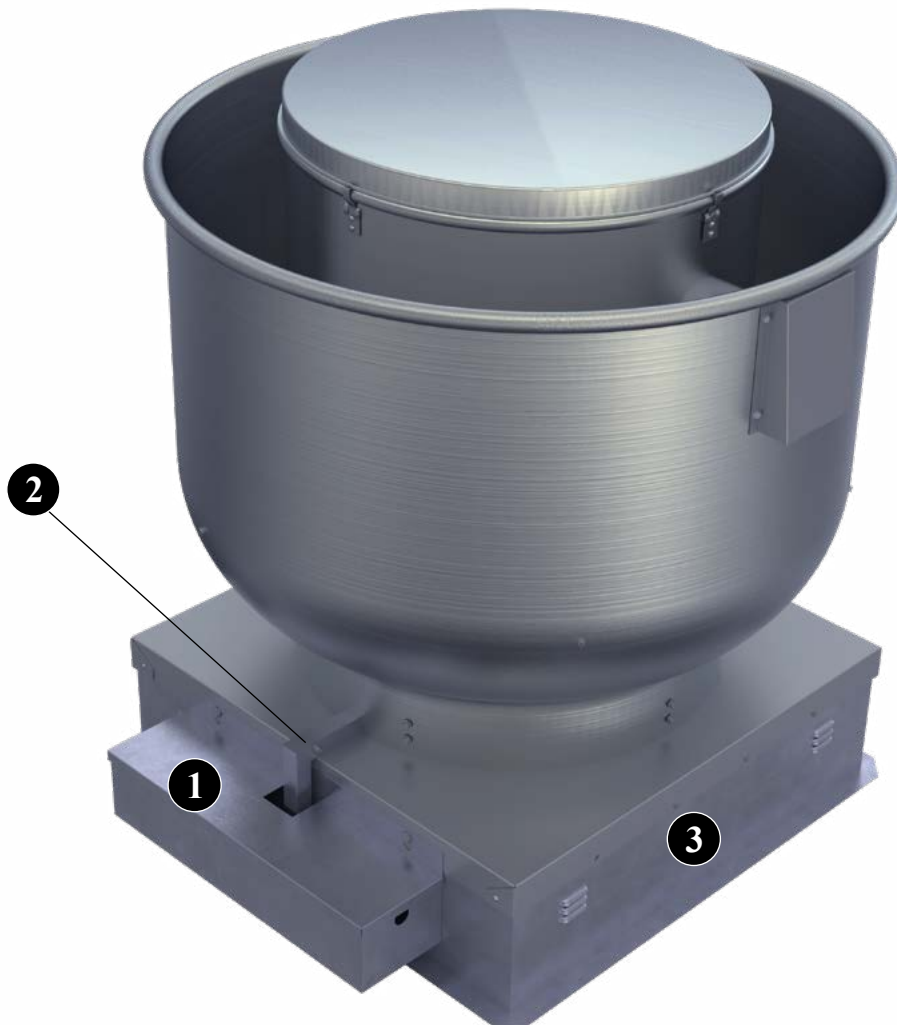

**1 Grease Box** Removable, for disposal of collected grease. Available for Model ATBR only.

**2 Drain Connection (Downspout)** Removable for disposal of collected grease. Available for Model ATBR only.

**3 Vented Roof Curbs** Self-flashing style curbs with ventilation louvers allow ambient air in to cool and dilute grease- or smoke-laden airstreams. Available for Models ATDR and ATBR only.

### OTHER ACCESSORIES/OPTIONS:

- Special Coatings
- Straight Sided Roof Curb (see page 10)
- Two-Speed Switch (Single-Phase, 1 HP and below)
- Firestat (Single-Phase)
- AMCA Spark B
- Performance Baffle
- Aluminum Bird Screen
- Stainless Steel Hardware
- Stainless Steel Shaft
- NEMA 4 Disconnect Switch (see page 9)
- NEMA 3R Disconnect Switch (see page 9)



## NEMA 1 Disconnect Switch

A NEMA 1 disconnect switch provides positive electrical shutoff during fan cleaning or maintenance of fan. Models ATB and AWX are provided with a NEMA 1 type disconnect switch in the motor compartment when ODP or TEFC motors are used.

## NEMA 3R Disconnect Switch

Models ATBR and AWXR are provided with a NEMA 3R rain-tight disconnect switch, externally mounted when ODP or TEFC motors are used. NEMA 3R, rain proof, disconnects are available shipped loose for field mounting and wiring or factory mounted and wired on Models ATB and AWX.

## NEMA 4 Disconnect Switch

A NEMA 4 disconnect switch (optional) is mounted externally and is water- and dust-tight. Switch is available shipped loose for field mounting and wiring or factory mounted and wired.

## NEMA 7/9 Disconnect Switch

NEMA 7/9 disconnect switches are provided as standard on fan packages with explosion proof motors. The NEMA 7/9 switch is designed for use with fans operating in hazardous environments. When explosion proof motors are specified, NEMA 7/9 disconnects will be shipped loose for field mounting and wiring. (Not shown.)



NEMA 1 Disconnect Switch



NEMA 3R Disconnect Switch



NEMA 4 Disconnect Switch

MODEL	STANDARD DISCONNECT SWITCH			
	NEMA 1	NEMA 3R	NEMA 4	NEMA 7/9
ATB	Standard	Optional	Optional	Standard, w/EXP motor*
ATBR	—	Standard	Optional	Standard, w/EXP motor*
AWX	Standard	Optional	Optional	Standard, w/EXP motor*
AWXR	—	Standard	Optional	Standard, w/EXP motor*

\* Always ships loose

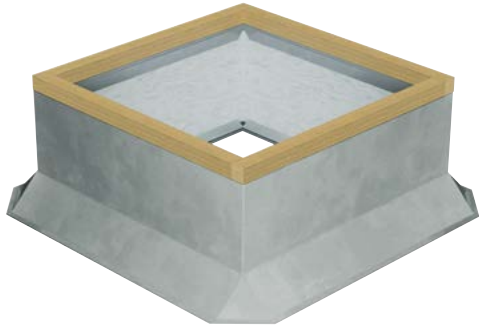

## Canted Roof Curbs

- Constructed of 18-gauge galvanized steel with continuously-welded seams
- Large 3" built-in 45° cant to accommodate roofing material to top of curb. Cant is beveled at corners for better support of roofing material
- Wood nailer (1 1/2") secured to top ledge
- Lined with 1 1/2" fiberglass fire-resistant, sound-absorbing insulation
- Damper shelf standard
- Options: Aluminum (16-gauge) construction, burglar security bars, metal liner (galvanized or aluminum), special heights up to 24", single- or double-pitched curbs for sloping roofs



## Self-Flashing & Straight-Sided Roof Curbs

- Constructed of 18-gauge galvanized steel with continuously-welded seams
- Wide base plate (flashing) to ensure watertight seal to roof
- Top ledge covered with 3/16" polystyrene gasket (self-flashing) for weather seal and to reduce metal-to-metal conducted noise
- Wood nailer secured to top ledge (straight-sided)
- Lined with 1 1/2" fiberglass fire-resistant, sound-absorbing insulation
- Damper shelf standard
- Straight-sided roof curbs are constructed with the same features as the self-flashing curbs, but are one dimensional to allow for field supplied cants and roofing material to be brought up to the top of the curb
- Options: Aluminum (16-gauge) construction, burglar security bars, metal liner (galvanized or aluminum), special heights up to 24", single- or double-pitched curbs for sloping roofs



## Self-Flashing Vented Roof Curbs For High Temperature Applications

- Completely assembled unit, easier to install and less expensive than a field constructed curb
- Constructed of 18-gauge galvanized steel with continuously-welded seams and wide base flashing for watertight seal to roof
- Meets NFPA-96 code requirements
- Top ledge covered with 3/16" polystyrene gasket
- Furnished with ventilation slots



## Curb Adapters

- Constructed of heavy-gauge galvanized steel with continuously-welded seams
- Top ledge covered with 3/16" polystyrene gasket to reduce metal-to-metal conducted noise and act as a weather seal
- Available in enlarger or reducer (shown) models

## ATB / ATBR

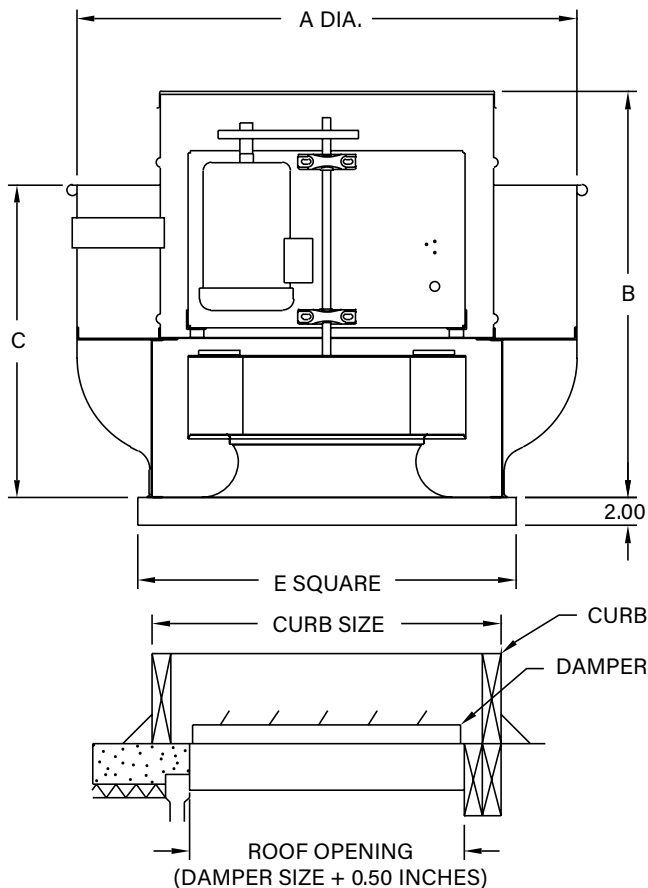

\* Damper not available on ATBR.

### Dimensional Data and Weights

MODEL		A	B	C	E	AVG. UNIT WT. (LBS.)
ATB	ATBR					
210B	210B	45.00	35.61	28.25	34.00	245
210BHP	210BHP	45.00	32.94	28.25	34.00	245
240B	240B	45.00	37.56	28.25	34.00	245
240BHP	240BHP	45.00	34.31	28.25	34.00	245
300B	300B	54.00	38.25	31.00	40.00	365
300BHP	300BHP	54.00	34.88	31.00	40.00	365
360B	360B	63.00	43.88	34.00	46.00	375
360BHP	360BHP	63.00	39.68	34.00	46.00	375
420B	—	69.00	46.75	36.00	52.00	385
480B	—	75.00	49.13	39.00	58.00	490

### Dampers and Roof Curbs

MODEL		DAMPER SIZE*	STANDARD CURB SIZE	SELF-FLASH CURB SIZE	ROOF OPENING
ATD	ATDR				
210B	210B	28 x 28	32 <sup>1</sup> / <sub>2</sub> x 32 <sup>1</sup> / <sub>2</sub>	33 <sup>1</sup> / <sub>2</sub> x 33 <sup>1</sup> / <sub>2</sub>	28 <sup>1</sup> / <sub>2</sub> x 28 <sup>1</sup> / <sub>2</sub>
240B	240B	28 x 28	32 <sup>1</sup> / <sub>2</sub> x 32 <sup>1</sup> / <sub>2</sub>	33 <sup>1</sup> / <sub>2</sub> x 33 <sup>1</sup> / <sub>2</sub>	28 <sup>1</sup> / <sub>2</sub> x 28 <sup>1</sup> / <sub>2</sub>
300B	300B	34 x 34	38 <sup>1</sup> / <sub>2</sub> x 38 <sup>1</sup> / <sub>2</sub>	39 <sup>1</sup> / <sub>2</sub> x 39 <sup>1</sup> / <sub>2</sub>	34 <sup>1</sup> / <sub>2</sub> x 34 <sup>1</sup> / <sub>2</sub>
360B	360B	40 x 40	44 <sup>1</sup> / <sub>2</sub> x 44 <sup>1</sup> / <sub>2</sub>	45 <sup>1</sup> / <sub>2</sub> x 45 <sup>1</sup> / <sub>2</sub>	40 <sup>1</sup> / <sub>2</sub> x 40 <sup>1</sup> / <sub>2</sub>
420B	—	46 x 46	50 <sup>1</sup> / <sub>2</sub> x 50 <sup>1</sup> / <sub>2</sub>	51 <sup>1</sup> / <sub>2</sub> x 51 <sup>1</sup> / <sub>2</sub>	46 <sup>1</sup> / <sub>2</sub> x 46 <sup>1</sup> / <sub>2</sub>
480B	—	50 x 50	56 <sup>1</sup> / <sub>2</sub> x 56 <sup>1</sup> / <sub>2</sub>	57 <sup>1</sup> / <sub>2</sub> x 57 <sup>1</sup> / <sub>2</sub>	50 <sup>1</sup> / <sub>2</sub> x 50 <sup>1</sup> / <sub>2</sub>

\*ATB Only

R-33719F

### Notes:

1. All dimensions are in inches unless otherwise noted.
2. Dimensions are not to be used for construction.
3. Damper sizes are nominal.
4. ATBR (Kitchen Exhaust) provided with self-flashing, vented, 12" high curb, built to 'standard' curb size dimensions above.



**AEROVENT**   
INDUSTRIAL VENTILATION SYSTEMS

## AWX / AWXR

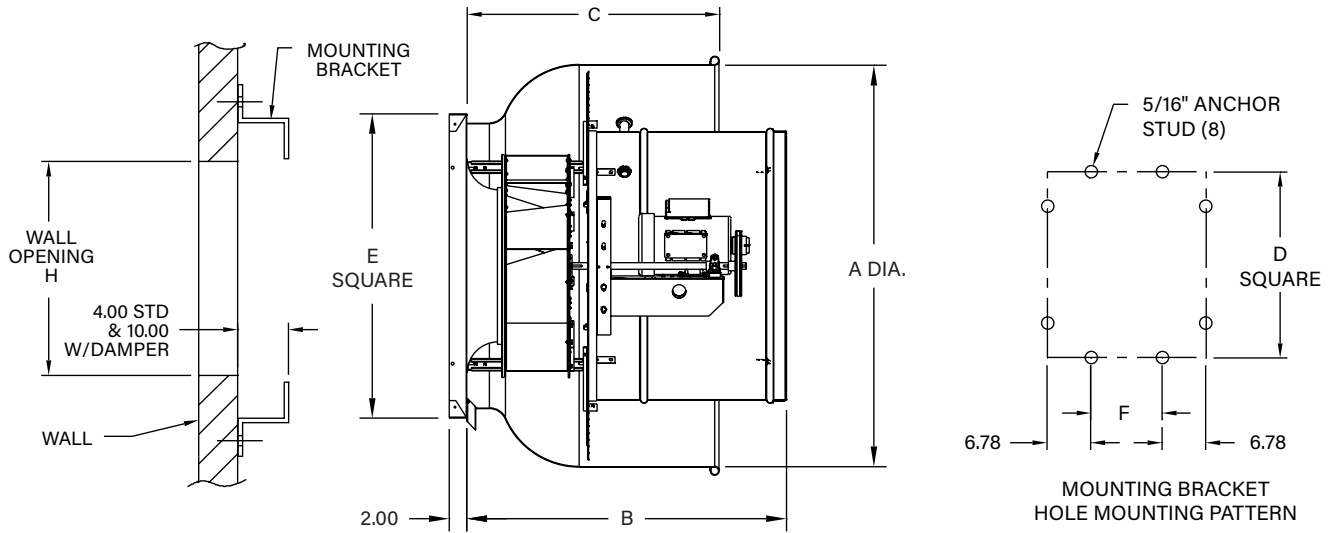

\* Damper not available on AWXR.

### Dimensional Data and Weights

MODEL		A	B MAX.	C	D	E	F	AVG. UNIT WT. (LB.)	DAMPER SIZE*	WALL MTG. BRACKET	WALL OPENING (H)
AWX	AWXR										
210B	210B	45.00	35.61	28.25	35.56	34.00	22.00	245	27 x 27	33 <sup>3</sup> / <sub>4</sub> x 33 <sup>3</sup> / <sub>4</sub>	27 <sup>1</sup> / <sub>2</sub> x 27 <sup>1</sup> / <sub>2</sub>
240B	240B	45.00	37.56	28.25	35.56	34.00	22.00	245	27 x 27	33 <sup>3</sup> / <sub>4</sub> x 33 <sup>3</sup> / <sub>4</sub>	27 <sup>1</sup> / <sub>2</sub> x 27 <sup>1</sup> / <sub>2</sub>
300B	300B	54.00	38.25	31.00	41.56	40.00	28.00	365	33 x 33	39 <sup>3</sup> / <sub>4</sub> x 39 <sup>3</sup> / <sub>4</sub>	33 <sup>1</sup> / <sub>2</sub> x 33 <sup>1</sup> / <sub>2</sub>

\*AWX Only

R-33720F

#### Notes:

1. All dimensions are in inches unless otherwise noted.
2. Dimensions are not to be used for construction.
3. Damper sizes are nominal.







## Models

**ATB | ATBR | AWX | AWXR**

Roof and wall mounted exhaust fans shall be of the belt driven centrifugal type and shall be ATB (upblast); ATBR (upblast kitchen exhaust); AWX (wall mount); and AWXR (wall mount kitchen exhaust) as manufactured by Aerovent, Minneapolis, Minnesota.

**PERFORMANCE** — Fans shall be tested in accordance with AMCA 210 and AMCA 300 test codes for air moving devices and shall be guaranteed by the manufacturer to deliver rated published performance levels. Fans shall be licensed to bear the AMCA certified ratings seal for both sound and air. Models ATB and AWX shall be cULus 705 listed. Models ATBR and AWXR shall be cULus 705 Supplement SC (formerly cULus 762) listed for the exhaust of grease-laden air.

**CONSTRUCTION** — Models ATB, ATBR, AWX and AWXR shall be constructed of aluminum for durability and appearance. Fan spinnings shall have a rolled bead edge for rigidity. Units shall have a deep venturi inlet to prevent snow and rain entry into the building. The curb cap shall include prepunched mounting holes for ease of installation. A conduit chase constructed of electrical metallic tubing shall be provided to the motor compartment. The curb cap shall provide protection from weather. Lifting lugs shall be provided inside the motor compartment for ease of handling and installation. Fans shall bear a permanently attached nameplate displaying model and serial number of the unit for future identification.

**MOTOR AND DRIVE ASSEMBLY** — Motor and drive assembly shall be mounted on vibration isolators to eliminate vibration and noise transmission into the ductwork. Motors and drives shall be mounted out of the exhaust airstream and shall have a cooling tube that provides air separate from the exhaust.

**IMPELLER** — Fan impellers shall be of the centrifugal backward inclined type, containing a matching inlet venturi for optimum unit performance. Fan impellers on models ATB, ATBR, AWX and AWXR shall be constructed of aluminum. Each impeller shall be statically and dynamically balanced in accordance with ANSI/AMCA 204-96 "Balance Quality and Vibration Levels for Fans" to Balance Quality Grade G6.3. Records shall be maintained and a written copy shall be available upon request.

**SHAFT** — Fan shafts shall be precision-ground and polished. Shafts shall have a first critical speed of at least 125% of the fan's maximum operating speed.

**BEARINGS** — Bearings shall be of the one-piece, pillow block type with relubricable zerk fittings. Bearings shall be designed for air handling service with a minimum L-10 life in excess of 100,000 hours; L-50 500,000 hours at the maximum cataloged operating speed. Bearing mounting plate shall have self-aligning tabs for exact locating and alignment of bearings.

**DRIVE** — Drive assembly shall be constructed of heavy-gauge galvanized steel. Drives shall be sized for a minimum of 150% of driven horsepower. Machined, cast iron motor sheaves shall be adjustable for final system balance.

**MOTOR** — Motors shall be heavy-duty ball bearing type, closely matched to the fan load. All single-phase ODP motors shall contain thermal overload protection. All motors shall be cULus recognized. Motor adjustment shall allow precise belt tensioning for optimum belt life and one-person adjustment and servicing.

**DISCONNECT SWITCH** — A NEMA 1 disconnect switch shall be supplied with wiring leading from the motor to the junction box on models ATB and AWX. A NEMA 3R disconnect switch shall be supplied with wiring leading from the motor to a junction box located outside of the motor compartment on models ATBR and AWXR.

**FINISH AND COATING** — Models ATB, ATBR, AWX and AWXR shall be constructed of aluminum. The entire fan assembly, excluding the shaft, shall be properly washed and pretreated before application of a rust-preventative primer, if called out on the order. After the fan is completely assembled, a finish coat of paint shall be applied to the entire assembly, if called out on the order. The fan shaft shall be coated with a petroleum-based rust protectant.

**ACCESSORIES** — When specified, accessories such as backdraft damper, roof curb, curb hinge, retaining chain, security hasp, NEMA 4 disconnect switch, two-speed switch, firestat, steel premium grease fan construction, aluminum bird screen, aluminum insect screen and special coatings shall be provided by Aerovent to maintain one source responsibility.

**FACTORY RUN TEST** — All fans prior to shipment shall be completely assembled and test run as a unit at operating speed or maximum RPM allowed for the particular construction type. Records shall be maintained and a written copy shall be available upon request.

---

**WALL MOUNTED FANS | TUBEAXIAL & VANEAXIAL FANS | CENTRIFUGAL FANS & BLOWERS**  
**ROOF VENTILATORS | AIR HEATERS & COOLERS | AIR MAKE-UP | FIBERGLASS FANS | CUSTOM FANS**

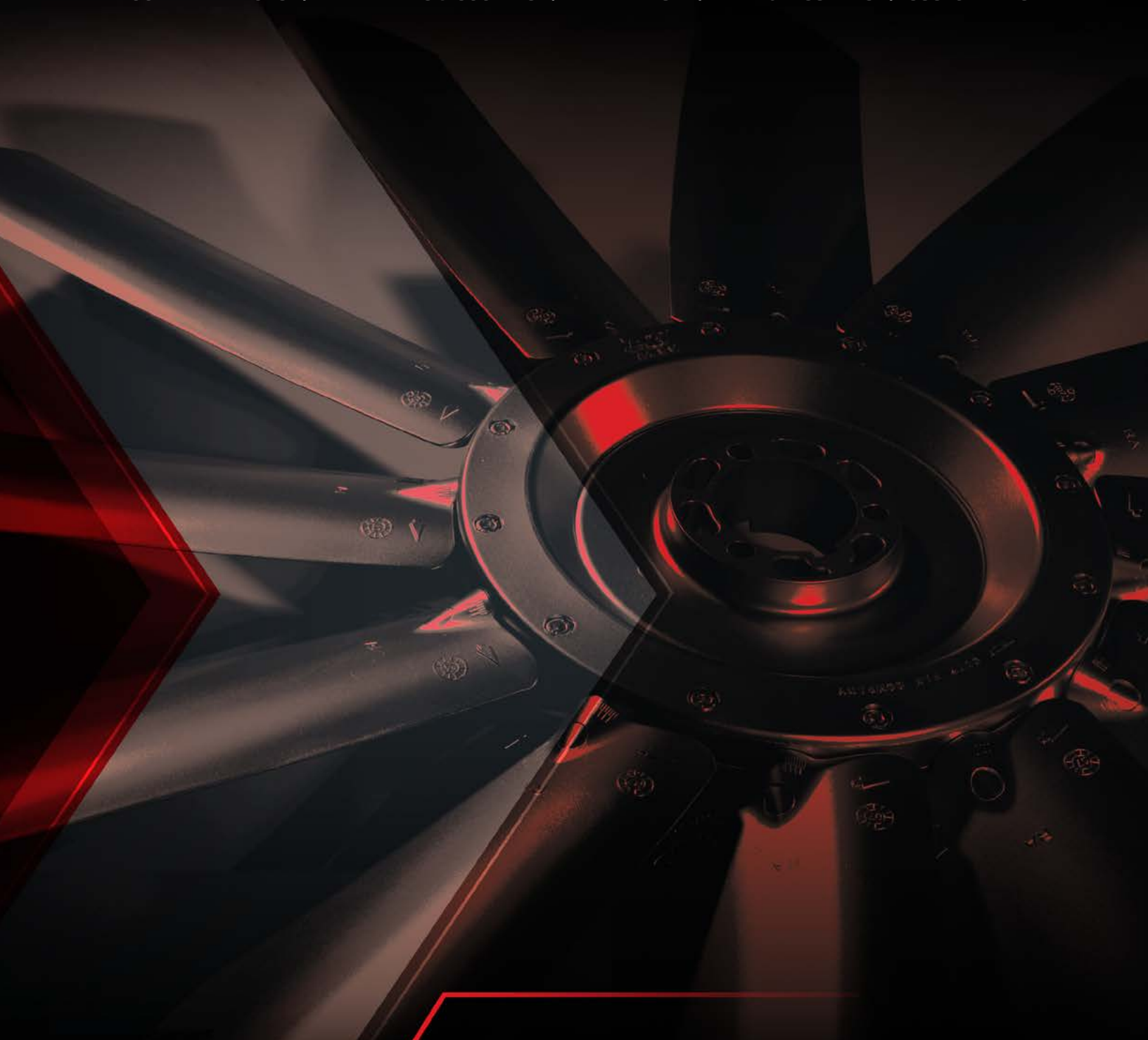

---

**AEROVENT**   
INDUSTRIAL VENTILATION SYSTEMS

**AEROVENT.COM**

---

**5959 Trenton Lane N. | Minneapolis, MN 55442 | Phone: 763-551-7500 | Fax: 763-551-7501**

©2023-2024 Aerovent, Minneapolis, MN. All rights reserved. Catalog illustrations cover the general appearance of Aerovent products at the time of publication and we reserve the right to make changes in design and construction at any time without notice.