



WING TON FAN INDUSTRY LIMITED



CEC SERIES SINGLE INLET SINGLE WIDTH
FORWARD CURVED CENTRIFUGAL FANS

CATA-AMCA-CEC, JANUARY 2021

CEC Series Single Inlet Single Width Forward Curved Centrifugal Fans



Wing Ton Fan Industry Limited certifies that the CEC Series Forward Curved Centrifugal Fans shown herein are licensed to bear the AMCA Seal. The ratings shown are based on tests and procedures performed in accordance with AMCA Publication 211 and AMCA Publication 311 and comply with the requirements of the AMCA Certified Ratings Program.

General Description:

- The CEC is a single inlet forward curved centrifugal fan. It offers a wide range of airflow and low static pressure development performances. The range comprises of three nominal product sizes with a selection of motor powers between 0.37 to 1.1kW.
- Air performance ranges from 500 m³/h up to 2,500 m³/h with the static pressure developments up to 1000 Pa. Direct-driven centrifugal fans are standard model.
- It is suitable for many OEM exhaust air applications and is particularly suited for incorporation into other third party light machinery. Typical applications

include:

- Industrial machines ventilation
- Motor Cooling
- Electronic cooling
- Ventilation system for Commercial and Industrial Kitchens



Construction:

- **Casing:**
The casings are made from electro-welded sheet steel and protected with a tough epoxy-polyester paint coating. The CEC ranges are supplied, as standard, with mounting flange and wire protection guard.
- **Fan/Impeller:**
All models incorporate a single inlet forward curved centrifugal impeller. They are manufactured from galvanized sheet steel. The impeller is factory fitted to the motor and dynamically balanced to ISO standard.
- **Motor:**
All models incorporate three phase induction motors with a squirrel cage rotor in die cast aluminum. All motors are IP55 Protection.

HOW TO CHOOSE A RIGHT FAN

Fan Selection:

Please select fans within the curve. Do not select above curve end, fan will work in stall and will be damaged. For a non-overloading selecting you can select motor on the peak-kW from each pitch angle which marks and cover maximum on absorbed.

Example:

Required duty point by customer

- Airflow: 500 m³/h (A)
- Static Pressure: 200 Pa (For total pressure 225 Pa (C), please add dynamic pressure 35 Pa (B) to static pressure 200 Pa)
- Fan Speed: 1440 RPM

After choosing right fan performance curve, please draw volume flow and pressure. In the cross you will find the following fan data:

- Motor Speed: 1440RPM
 - Fan Efficiency: 53%(E)
 - Sound Power Level: 77 dB (G)
- and the peak absorbed power is 0.08Kw(D)

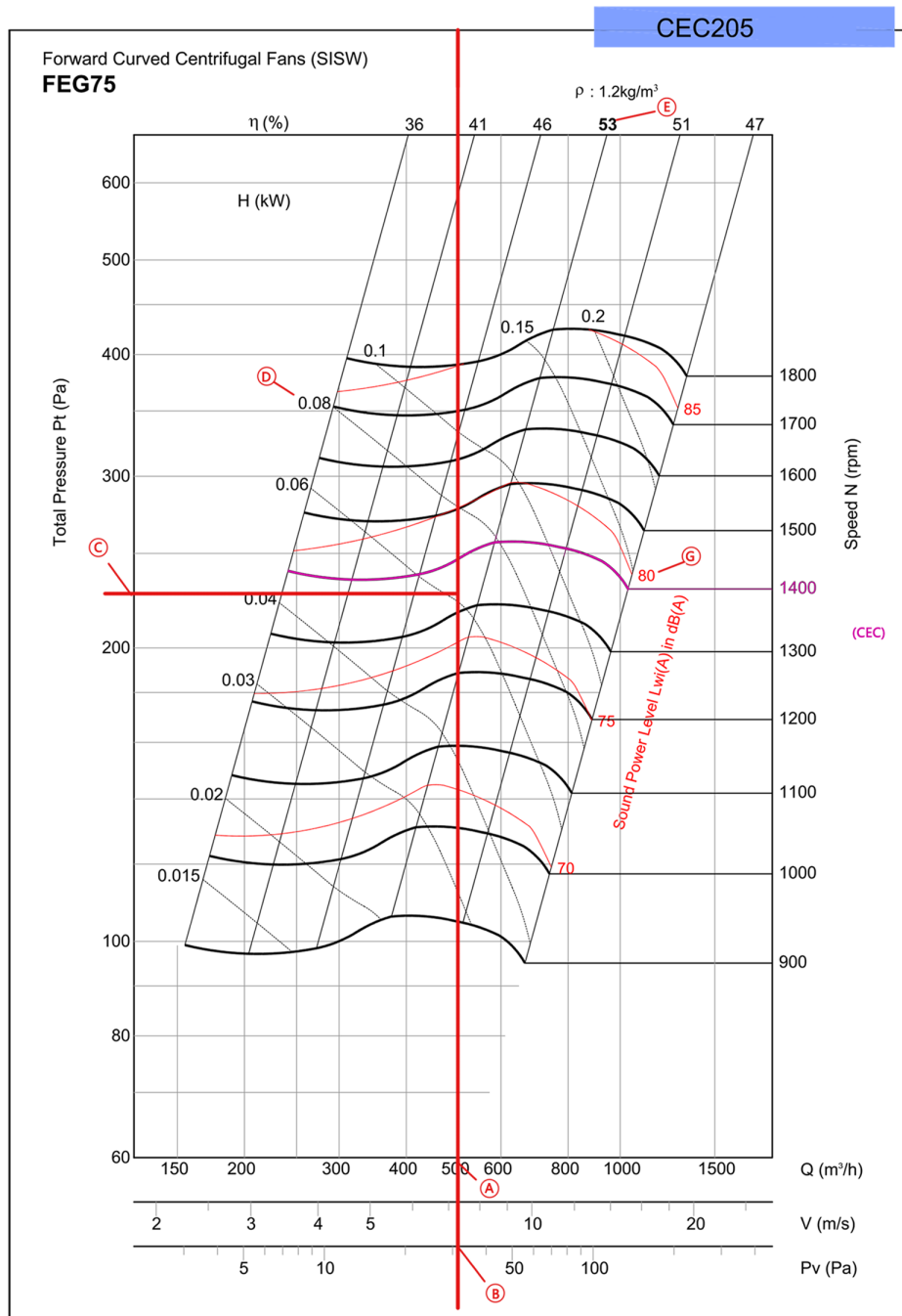

- Performance certified is for installation type B - Free inlet, Ducted outlet. Power rating kW does not include transmission losses. Performance ratings do not include the effects of appurtenances (accessories)
- The A-weighted sound ratings shown have been calculated per AMCA International Standard 301. Values shown are for inlet LwA sound power levels for installation Type B: free inlet, ducted outlet.

CEC150

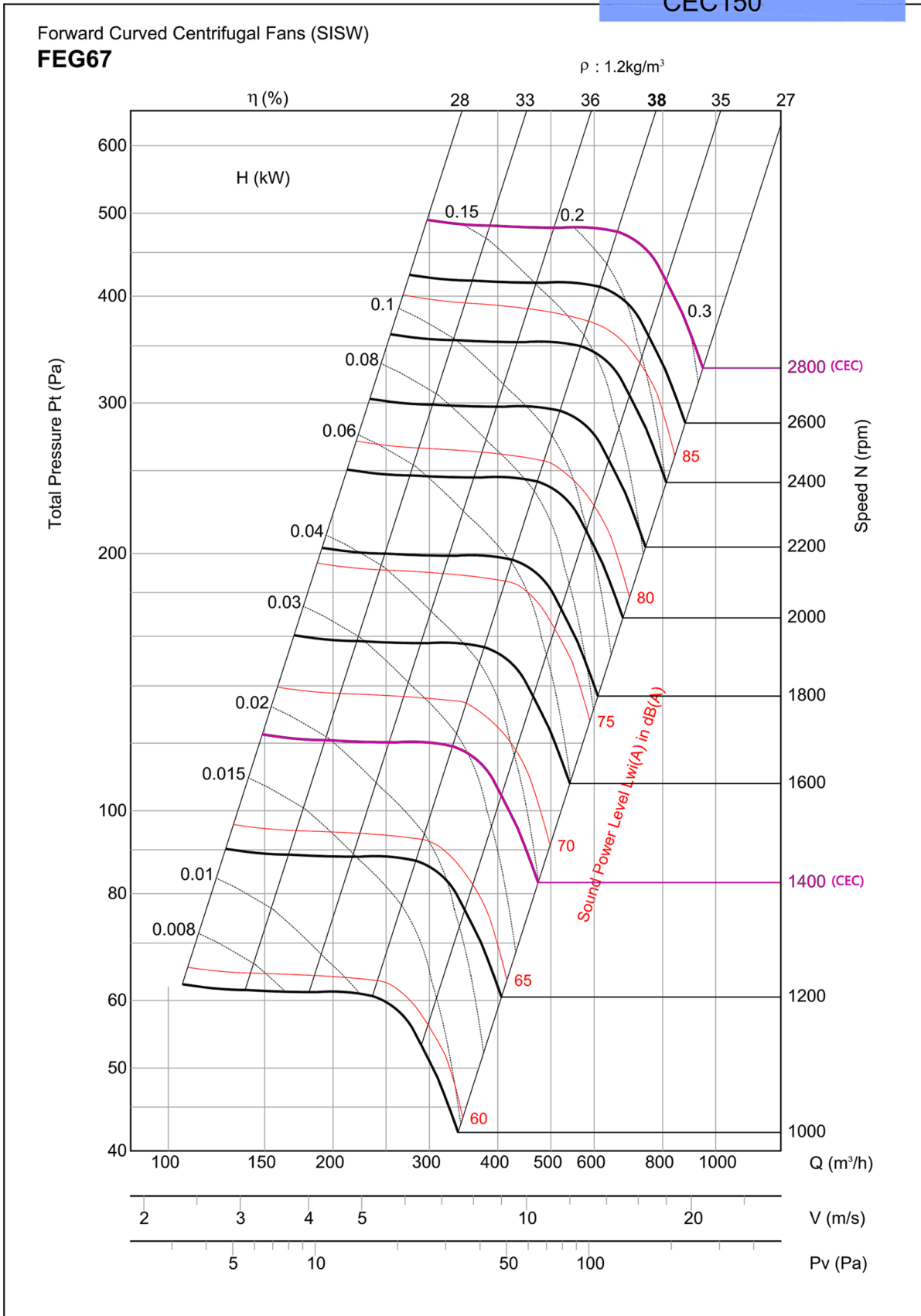

- Performance certified is for installation type B - Free inlet, Ducted outlet. Power rating kW does not include transmission losses. Performance ratings do not include the effects of appurtenances (accessories)
 - The A-weighted sound ratings shown have been calculated per AMCA International Standard 301. Values shown are for inlet LwA sound power levels for installation Type B: free inlet, ducted outlet.

CEC Series Single Inlet Single Width Forward Curved Centrifugal Fans

CEC205

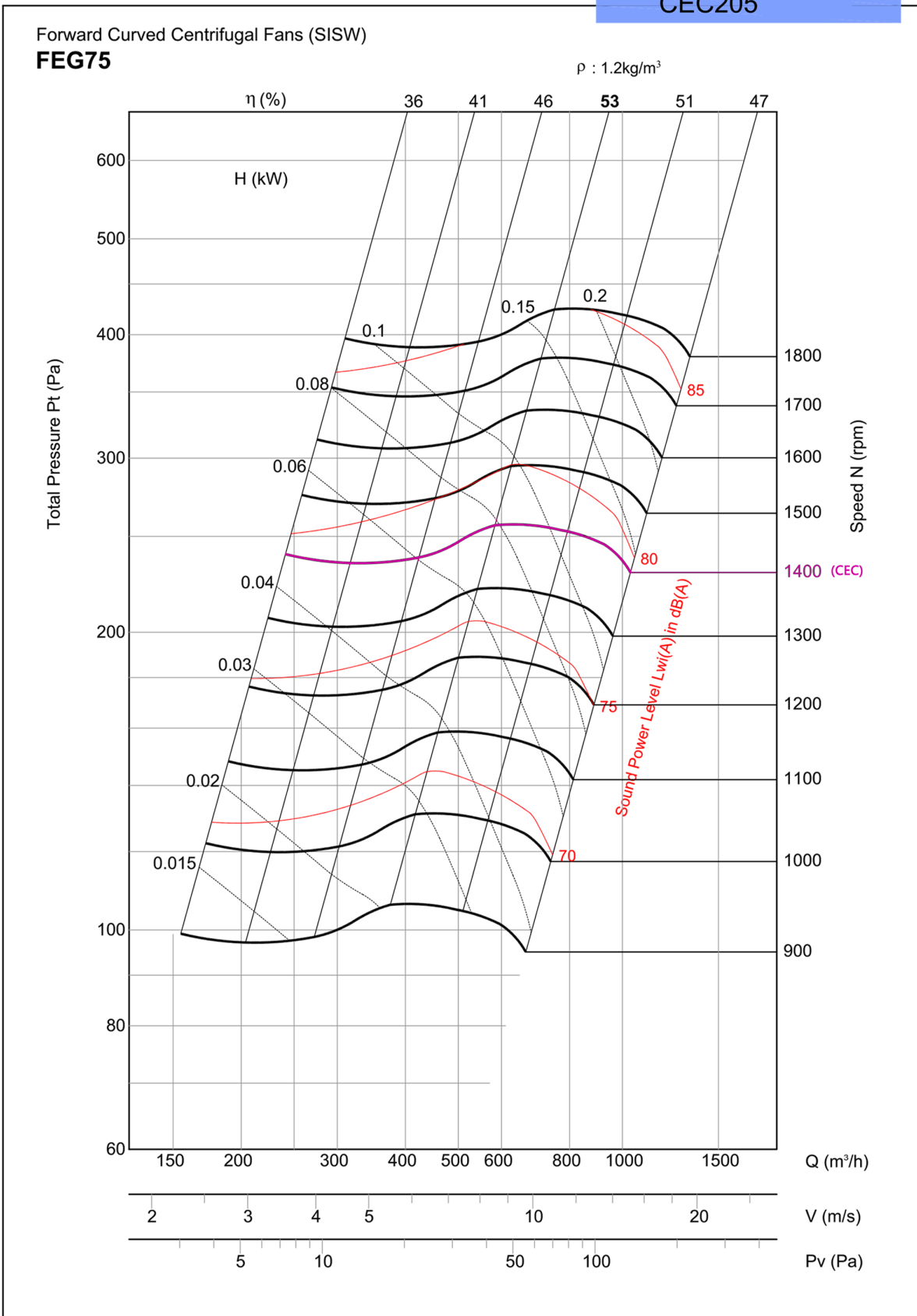

- Performance certified is for installation type B - Free inlet, Ducted outlet. Power rating kW does not include transmission losses. Performance ratings do not include the effects of appurtenances (accessories)
 - The A-weighted sound ratings shown have been calculated per AMCA International Standard 301. Values shown are for inlet Lw(A) sound power levels for installation Type B: free inlet, ducted outlet.

CEC Series Single Inlet Single Width Forward Curved Centrifugal Fans

CEC255

Forward Curved Centrifugal Fans (SISW)
FEG85

$\rho : 1.2\text{kg/m}^3$

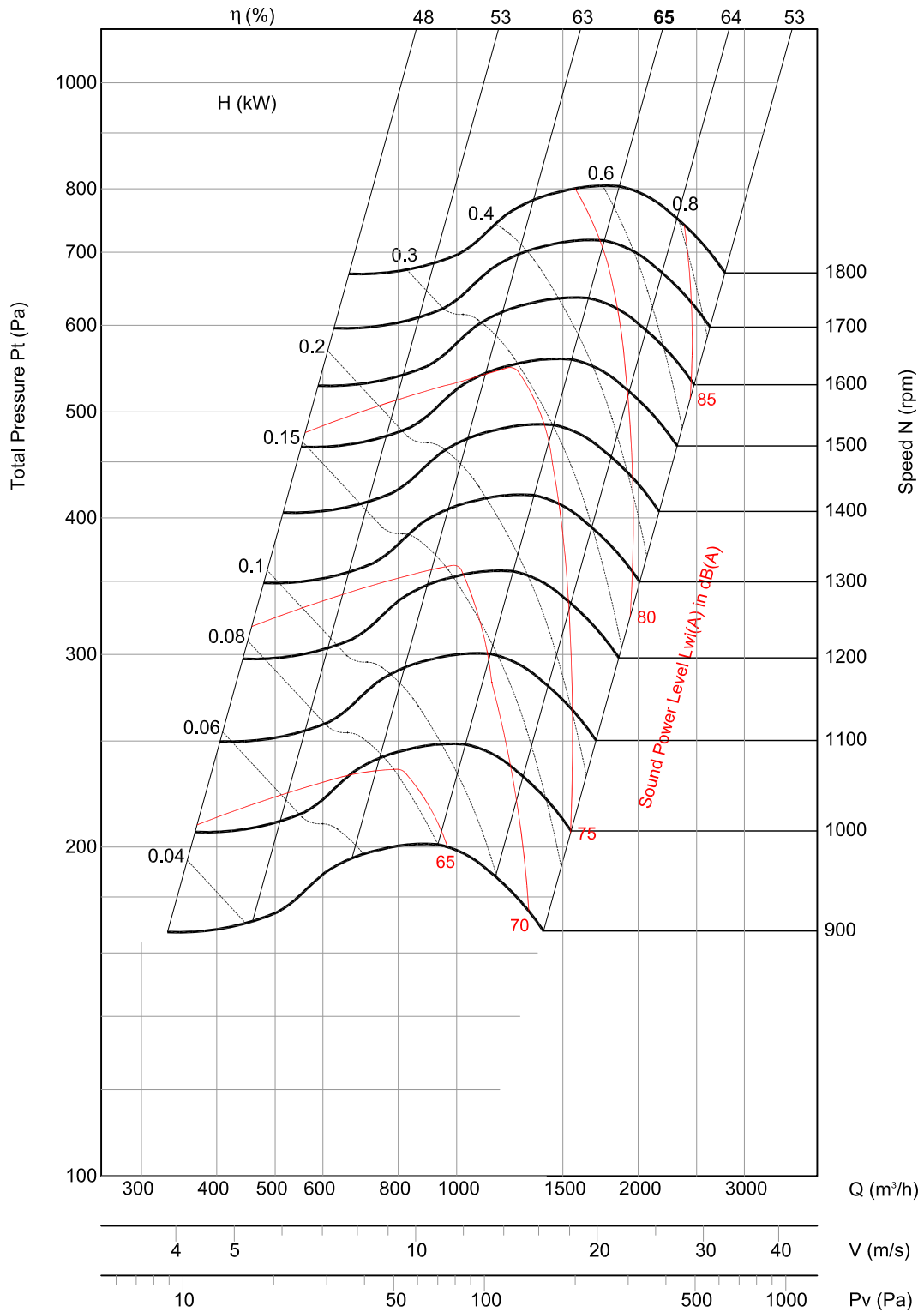

- Performance certified is for installation type B - Free inlet, Ducted outlet. Power rating kW does not include transmission losses. Performance ratings do not include the effects of appurtenances (accessories)
- The A-weighted sound ratings shown have been calculated per AMCA International Standard 301. Values shown are for Inlet LwA sound power levels for Installation Type B: free Inlet, ducted outlet.



CEC Series Single Inlet Single Width Forward Curved Centrifugal Fans.

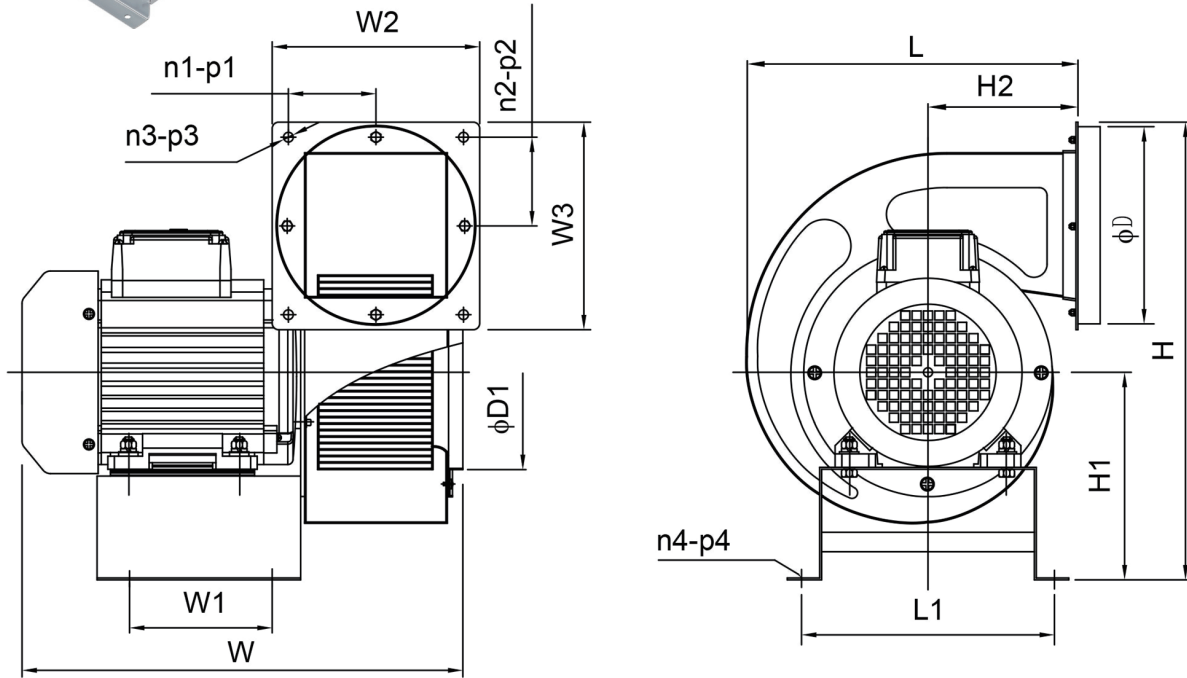

Model	ØD	ØD1	W	W1	W2	W3	H	H1	H2	L1	L2	n1-p1	n2-p2	n3-p3	n4-p4
150mm	150	150	340	110	160	160	355	160	116	255	195	1-140	1-140	4-Ø7.5	4-Ø8.5
205mm	200	200	366	110	197	197	430	185	146	324	235	2-85	2-85	8-Ø7.5	4-Ø8.5
255mm	250	250	400	140	220	250	535	226	177	380	265	2-90	2-90	8-Ø7.5	4-Ø8.5

GENERAL TECHNICAL CHARACTERISTICS FOR CEC SERIES - DIRECT DRIVE CENTRIFUGAL FANS

Model Type	Motor Power (Kw)	Fan Speed (RPM)	Air Volume (m3/h)
CEC150EBV	0.33	2800	980
CEC150FBV	0.14	1400	490
CEC205FBV	0.27	1400	1200
CEC255FBV	0.62	1400	2100



WING TON FAN INDUSTRY LIMITED



Address: 1B KAM SHING IND BLDG,1-11 KWAI WING RD.KOWLOON,HONG KONG.

Tel: (852) 2410 9038 Fax: (852) 2487 7317

E-mail: edwin@wington.hk <http://www.wington.com>