

# The Straight Way

## Rectangular Cabinet Fan



Systemair Sdn Bhd certifies that the Rectangular Cabinet Fan shown herein are licensed to bear the AMCA Seal. The ratings shown are based on tests and procedures performed in accordance with AMCA Publication 211 and AMCA Publication 311 and comply with the requirements of the AMCA Certified Ratings Program.

# Rectangular Cabinet Fan

## CDRE

The Systemair Rectangular Cabinet Fan units are the results of long experience in the development and manufacturing of ventilation systems. The partnership between highly motivated Systemair employees and world know component suppliers guarantees quality products on the highest technical level and precise reliability.

### The Systemair advantages:

- Modular system : Casings can be disassembled, if required. Easy installation.
- Min. 25mm perforated panels manufactured from pre-galvanised mild steel with non-flammable mineral wool infill for thermal and acoustic insulation.
- All units are fitted with fans from the Systemair range, with external rotor motors for the direct driven units.
- Compact design
- Low-level noise

### The Systemair quality:

Plug fans are installed in the Rectangular Cabinet Fans. The impeller with backward curved blades are external rotor motor and standard foot mounted motor (P44, 54 & 55) steel & aluminium impeller for all sizes.

These plug fans are mounted on a motor supporting frame; the motor and impeller assembly is balanced dynamically in two levels according to VDI 2060. quality 0 2, 5.

Tolerance in accordance with technical conditions of supply of fans DIN 24166, class 3.

Panel insulation is provided by non flammable (A1) mineral fibre slab in accordance with DIN 4102.

Thermal insulation  $K = 0.89 \text{ W/m}^2\text{k}$  in acc. With DIN 52210

Sound insulation  $R_w = \text{appr. } 25\text{dB}$  in acc. With DIN 52210.



### The Systemair accessories:

- Flexible connections
- Shutters
- Counter Flanges

### The Systemair performance curves:

Have been tested using a test chamber in accordance with AMCA 210. The values refer to an air density of  $1.2 \text{ kg/m}^3$  at  $20^\circ\text{C}$ .

### Noise levels:

The technical data show the A-weighted sound pressure levels LPA.

Tolerance in accordance with technical conditions of supply of fans DIN 24166, class 3, noise level ca.  $0.5 \times \sqrt{\text{pfa max}}$ .

### The Systemair selection criteria:

- Size
- Air volume
- Static Pressure
- Sound requirements



## Reference Code

CDR

CDR Model ( Rectangular Cabinet Fan )

E /D

315

E = Single phase AC      Impeller diameter

D = Three phase AC



**PLEASE NOTE THE FOLLOWING ADVISE  
FOR INSTALLATION AND OPERATION  
OF SYSTEMAIR FANS**

### Safety Rules :

- Before you do any work on the fan you must disconnect the electrical supply first.
- The buyer is responsible that the local codes are being followed.
- During all maintenance works, the electrical connections must be checked.

### Warranty rules :

- The buyer is responsible for the selection and operations of the fan.
- The warranty is only for fans which are operating under normal conditions. Warranty is only valid when thermal protections (TK) are used.
- If the delivered goods shows failures, the customer can claim the exchange of the product or parts of it up to the amount of the buying price.
- Claims for secondary damages are not accepted.
- We reserve the rights to change the construction and design without notice, for the purpose of technical progress.

Rectangular Cabinet Fans

CDRE 315

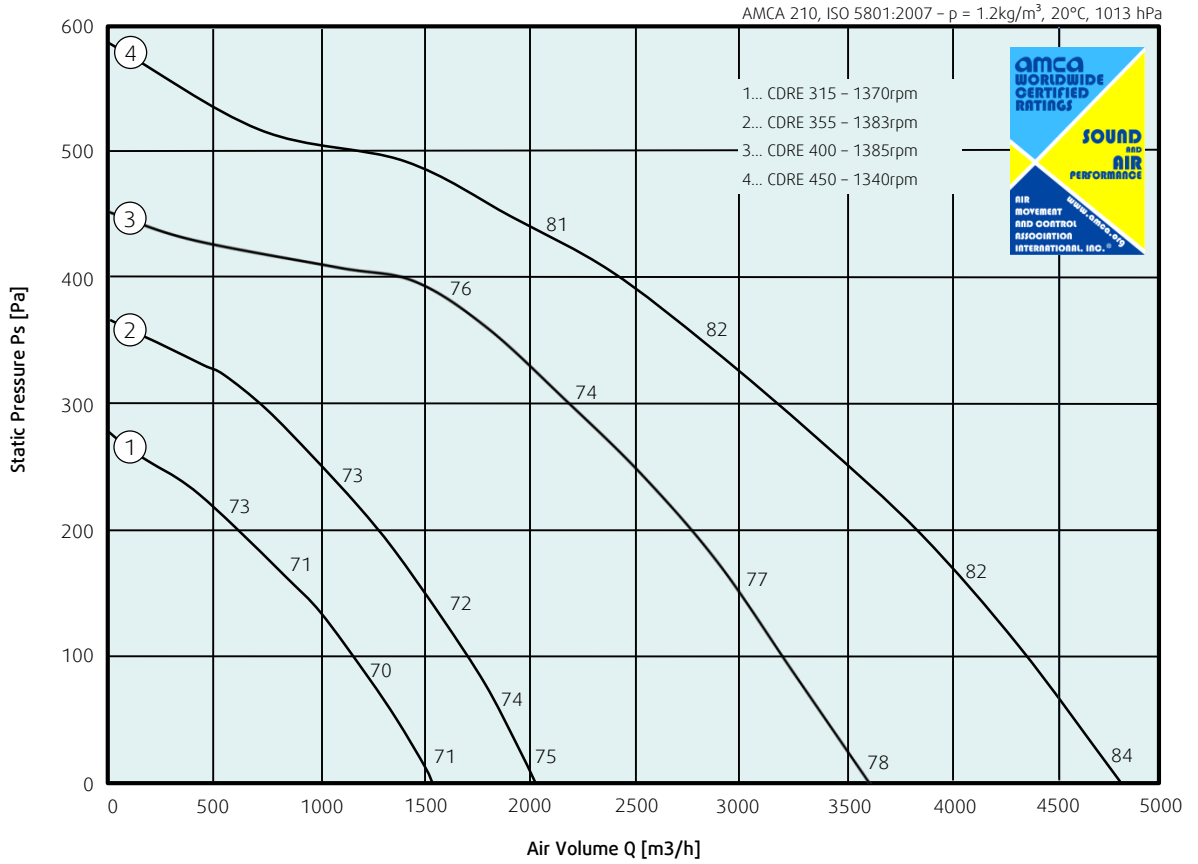

		CDRE 315	CDRE 355	CDRE 400	CDRE 450
Voltage	V	220	230	230	230
Frequency	Hz	50	50	50	50
Phase	-	1	1	1	1
Max. Motor Input Watts	W	140	225	480	750
Max. Current	A	0.68	0.94	2.1	3.2
Nominal Speed	RPM	1370	1383	1385	1340
Max. Airflow	m <sup>3</sup> /h	1537	2034	3640	4817
Sound Pressure level LpA at 3m	dB(A)	51	55	58	63
Max. Temperature	°C	45	60	50	60
Motor Insulation Class		F	F	F	F
Motor Protection	IP	44	44	54	54
Capacitor	µF	4	6	10	14
Weight	kg	16	20	25	30

**SOUND DATA**

Single figure on performance curves are overall inlet LwIA sound power levels, derived from measurements taken in laboratory specifically under ducted conditions. Following is the inlet LwI sound power levels (dB) in eight octave bands maximum airflow (0Pa) :

Model	63	125	250	500	1K	2K	4K	8K	Overall
CDRE 315	84	83	72	66	60	58	57	48	87
CDRE 355	86	88	74	69	63	60	63	55	90
CDRE 400	90	88	79	75	67	64	63	71	92
CDRE 450	88	93	84	79	74	73	74	70	95

The sound power ratings shown are in decibels, referred to 10<sup>-12</sup> watts, calculated per AMCA International Standard 301.

- Performance certified is for installation type D-Ducted inlet. Ducted outlet. Speed (RPM) shown is nominal. Performance is based on actual speed of test. Performance ratings do not include the effects of appurtenances (accessories)
- The A-weighted sound ratings shown have been calculated per AMCA international Standard 301. Values shown are for inlet LwI and LwIA sound power levels for installation type D ducted inlet, ducted outlet. Ratings include the effects of duct end correction. Sound pressure level LpA at 3m are not licensed by AMCA international.

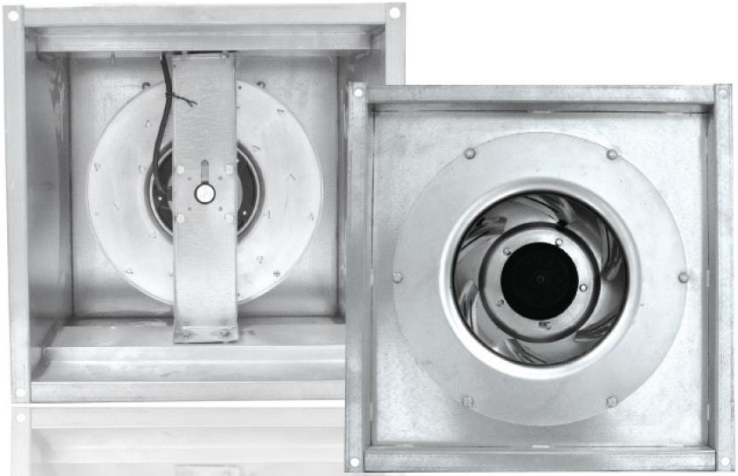

Rectangular Cabinet Fans  
CDRE 315

### Dimensions

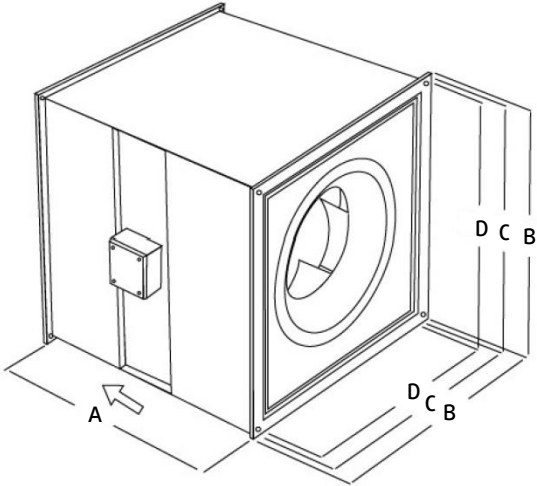

CDRE	IN METRIC			
	A	B	C (P.C.D.)	D
315	400	450	425	400
355	550	550	525	500
400	600	650	625	600
450	600	650	625	600

NO LIABILITY FOR ERRORS – SUBJECT TO TECHNICAL MODIFICATIONS

# Rectangular Cabinet Fan

## CDRD



- 1... CDRD 400 – 1390rpm
- 2... CDRD 450 – 1380rpm
- 3... CDRD 500 – 1435rpm
- 4... CDRD 560 – 1456rpm
- 5... CDRD 630 – 1471rpm

## Performance Data & Curves

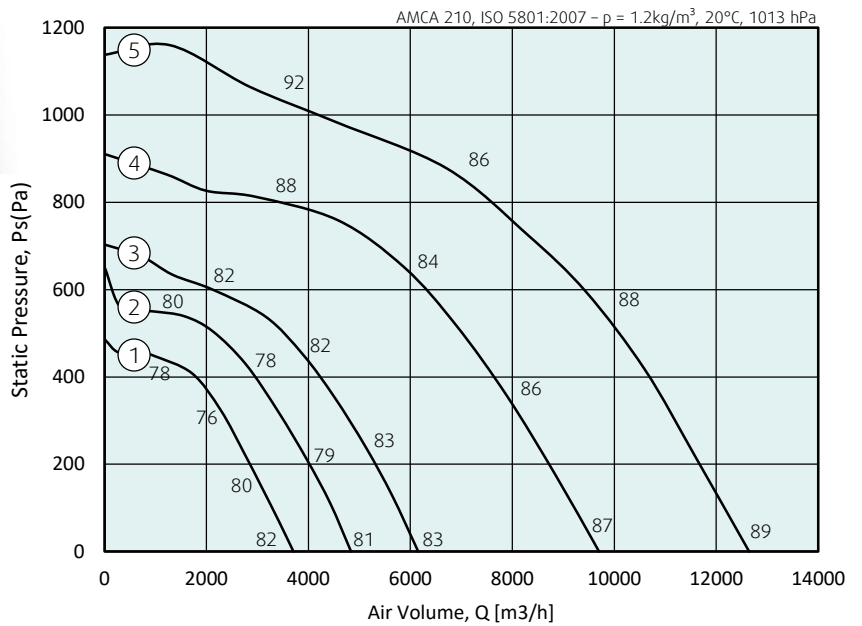

		CDRD 400	CDRD 450	CDRD 500	CDRD 560	CDRD 630
Voltage	V	415	415	415	415	415
Frequency	Hz	50	50	50	50	50
Phase	-	3	3	3	3	3
Max. Motor Input Watts	W	500	980	1359	2432	3893
Motor size	kW	0.55	0.75	1.5	3	4
Max. Current	A	1.49	1.98	3.2	6.0	7.9
Nominal Speed	RPM	1390	1380	1435	1456	1471
Max. Airflow	m <sup>3</sup> /h	3708	4838	6152	9702	12643
Sound Pressure level LpA at 3m	dB(A)	61	60	63	67	69
Max. Temperature	°C	40	40	40	40	40
Motor Insulation Class		F	F	F	F	F
Motor Protection	IP	55	55	55	55	55
Weight (approx.)	kg	44	46	65	85	110

## Sound Data

Single figure on performance curves are overall inlet LwiA sound power levels, derived from measurements taken in laboratory specifically under ducted conditions. Following is the inlet Lwi sound power levels (dB) in eight octave bands at maximum airflow (0Pa):

Model	63	125	250	500	1k	2k	4k	8k	Overall
CDRD 400	85	87	79	73	70	78	75	60	82
CDRD 450	90	92	83	76	72	70	65	66	81
CDRD 500	93	93	86	80	72	71	68	70	97
CDRD 560	94	97	90	81	79	76	73	76	99
CDRD 630	95	99	92	83	81	78	77	77	101

- Performance certified is for installation type D – Ducted inlet, Ducted outlet, Speed (RPM) shown is nominal. Performance is based on actual speed of test. Performance ratings do not include the effects of appurtenances (Accessories).
- The A-weighted sound ratings shown have been calculated per AMCA International Standard 301. The sound power level ratings shown are in decibels, referred to 10<sup>-12</sup> watts, calculated per AMCA International Standard 301. Values shown are for inlet Lwi and LwiA sound power levels for installation type D : ducted inlet, ducted outlet. Ratings include the effects of duct end correction. Sound pressure level LpA at 3m are not licensed by AMCA International.





Direct Drive Rectangular In-Line Fan  
CDRD 500

### Dimensions

#### Features

- The CDRD Cabinet In-line Duct Fan – a series of duct mounted in-line centrifugal suitable for supply or exhaust from applications ranging from residential & commercial to industrial.
- Galvanised steel housing and flanged connections.
- Backward curve centrifugal impellers.
- Fan units are lightweight and can be mounted at any angle.

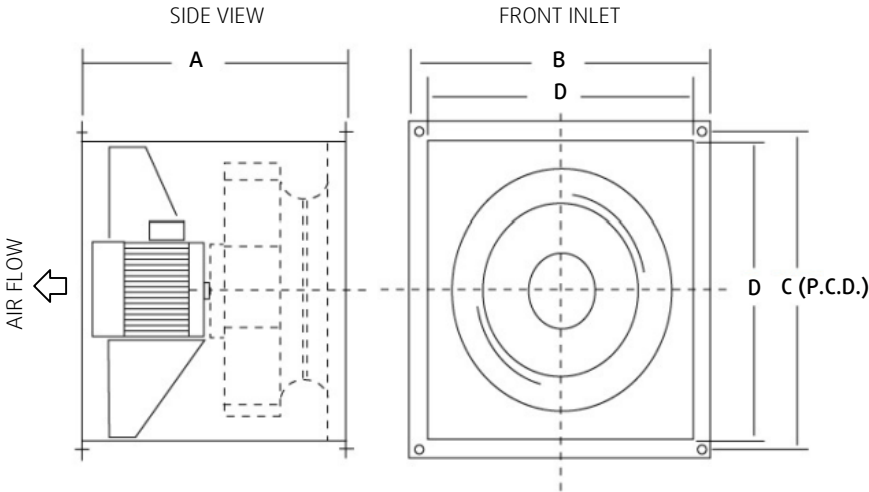

#### Motors

- Type – can supplied with direct-driven standard TEFC motors.
- Electrical supply – three-phase to suit a wide range of voltages and frequencies.

MODEL	IN METRIC			
	A	B	C	D
CDRD 400	600	650	625	600
CDRD 450	600	650	625	600
CDRD 500	650	710	680	650
CDRD 560	750	785	755	725
CDRD 630	800	850	825	800

NO LIABILITY FOR ERRORS – SUBJECT TO TECHNICAL MODIFICATIONS



Systemair Sdn Bhd ( 816114-X)  
Lot 1565, Kampung Jaya Industrial Area  
Jalan Kusta, 13 1/2 Miles, Sungai Buloh  
47000 Selangor Darul Ehsan, Malaysia

Tel : +603 615 711 77  
Fax : +603 615 666 18

[info@systemair.my](mailto:info@systemair.my)  
[www.systemair.my](http://www.systemair.my)

CDRE/D May 2024