



INDUSTRIAL PROCESS AND
COMMERCIAL VENTILATION SYSTEMS

HIGH VELOCITY FUME EXHAUST FAN

Model TFE



FUME EXHAUST FAN



Overview

TFE

Twin City Fan & Blower offers a specially modified version of the TSL fan designated as TFE for laboratory fume hood exhaust applications, available in sizes 90 through 542.

The TFE fume exhaust fan consists of a vertically mounted tubular inline fan with a reinforced curb cap and stack cap. The stack cap includes an outlet venturi nozzle, increasing the outlet velocity to meet stringent roof exhaust requirements and maximize the overall plume height of the laboratory exhaust.

The Model TFE fan includes a heavy-duty curb cap as standard. An optional modular mixing plenum box provides additional bypass air and the capability of multi-fan systems and future expandability.

Model TFE offers a wide range of nozzle sizes for each fan size to effectively accelerate the exhaust stream based on the specific building exhaust needs.

Typical Applications Include

Lab Exhaust for Universities, Schools, Hospitals and Research Facilities

Configurations

Available in belt driven, Arrangement 9 configuration only

Construction

Class I & II

Impeller Types

Centrifugal

- Single thickness flat-blade backward inclined blades (Sizes 90-150)
- Airfoil blades (Sizes 182-542)

Optional Construction

Special Materials, Spark Resistant Construction, Special Coatings, Special Width Impeller

Certifications

AMCA Sound/Air and FEI, UL 705 Listed for Electrical



Model TFE is available with UL/cUL 705 listing, for electrical, File No. E158680.



Twin City Fan & Blower certifies that the Model TFE Fume Hood Exhaust Fans shown herein are licensed to bear the AMCA Seal. Certified performance data may be found in Twin City Fan & Blower's Fan Selector software.



Scan the QR code to search Twin City Fan & Blower's AMCA-certified products.



For complete product performance, drawings and available accessories, download our Fan Selector software at tcf.com.

Application

TFE

The Model TFE High Velocity Exhaust Fan is intended for use in exhausting laboratory fumes and hazardous chemicals in such a manner that diminishes the likelihood of concentrated, contaminant-laden air from being re-entrained into the building's intake or makeup air. These units are commonly used in exhaust systems for universities, schools, hospitals, research facilities, laboratories, restaurants and wastewater treatment plants.

High Velocity Exhaust Fans exhaust contaminated air at the outlet at a higher outlet velocity. This increases the plume height of the fan without a tall stack.

Benefits of Model TFE

Twin City Fan & Blower's Model TFE is ideally suited for applications such as high schools and elementary schools with intermittent use due to the available positive shut-off damper at the outlet of the venturi nozzle. The positive shut-off damper completely seals the interior of the fan from the elements, giving complete rain protection even when the fan is not running! Model TFE is also an ideal choice for laboratories and universities requiring continuous use, but do not require the high-dilution of an induced flow fan.

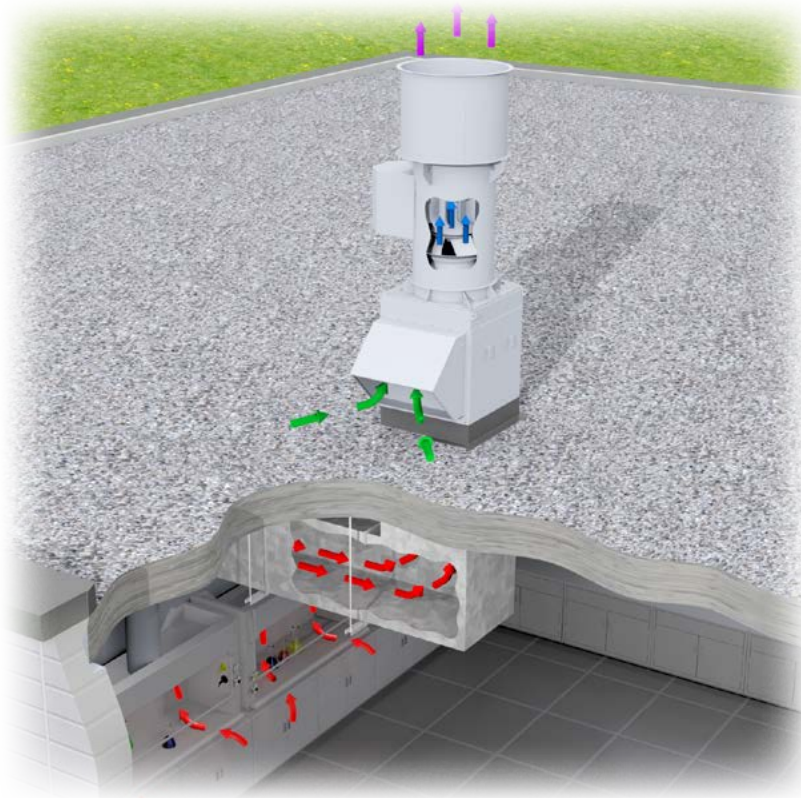

Energy Regulations

Twin City Fan & Blower supports energy efficiency regulations enacted by the U.S. Department of Energy (DOE) and specific states. The selection and application of fan products is a significant part of these regulations. Engineers and specifiers must understand how to apply TCF products to their specific applications to meet applicable DOE and state regulatory requirements. Twin City Fan & Blower has made significant investments in product testing and development to provide efficient products. Developments in Twin City Fan & Blower's Fan Selector software are in place to aid your decision in product selection to assist with meeting the efficiency requirements as stipulated in the applicable regulations.

Performance Data

9" to 54.25" impeller diameters
Airflow to 78,000 CFM
Static pressure to 8" w.g.





Housing

All fans are constructed of heavy-gauge steel and continuously-welded for strength and rigidity. All TFE fans are provided with punched inlet and outlet flanges as standard.

Straightening Vanes

Straightening vanes convert tangential velocity pressure into useful static pressure, reducing turbulence and increasing efficiency. Extensive testing of various shapes and locations has resulted in the most efficient aerodynamic design of the straightening vanes.

Weather Cover

Weather covers completely enclose the motor and V-belt drive from the elements. Provided with slots for ventilation, covers are easily removable for inspection and maintenance.

Curb Cap

Attached to the fan's inlet flange for curb mounting. Standard accessory on TFE without mixing plenum box.

Extended Lube Lines

Allow for ease of lubrication on all sizes.

Stainless Steel Hardware

Corrosion resistant stainless steel hardware is standard.

Bearings

Standard bearings are selected to exceed the L-10 life of 200,000 hours at the maximum operating speed.

Drives

Cast iron, adjustable or fixed pitch drives are selected for at least 200% of motor horsepower. Adjustable sheaves are provided on motors up to 10 HP, fixed sheaves for 15 HP and above.

V-belt drives with motors and drives mounted by Twin City Fan & Blower are set to the required RPM and test run as a complete assembly and rechecked for balance.

Sealed Belt Tube

A sealed belt tube encloses the belts and drive components, protecting them from the airstream.

Motor Mounting Platform

A heavy-duty motor mounting platform pivots to offer easy and positive adjustment of belt tension.

Inner Cylinder

The inner tube is rigidly constructed to support the shaft and bearings. The removable discharge cone provides full access to the shaft, bearings and fan sheave.

Drain

A drain coupling welded to the lowest point of the housing allows drainage of condensate from fan housing.

Bolted Access Door

Impeller area access door for inspection or cleaning of the impeller.

Shaft Seal

To limit the air entering the inner cylinder and avoid contact of airstream contaminants with the bearings and V-belt drive. Consists of a Teflon wear pad/plate and a rubber check seal at the impeller end of the inner cylinder. Please note that a shaft seal does not make the inner cylinder gas tight.

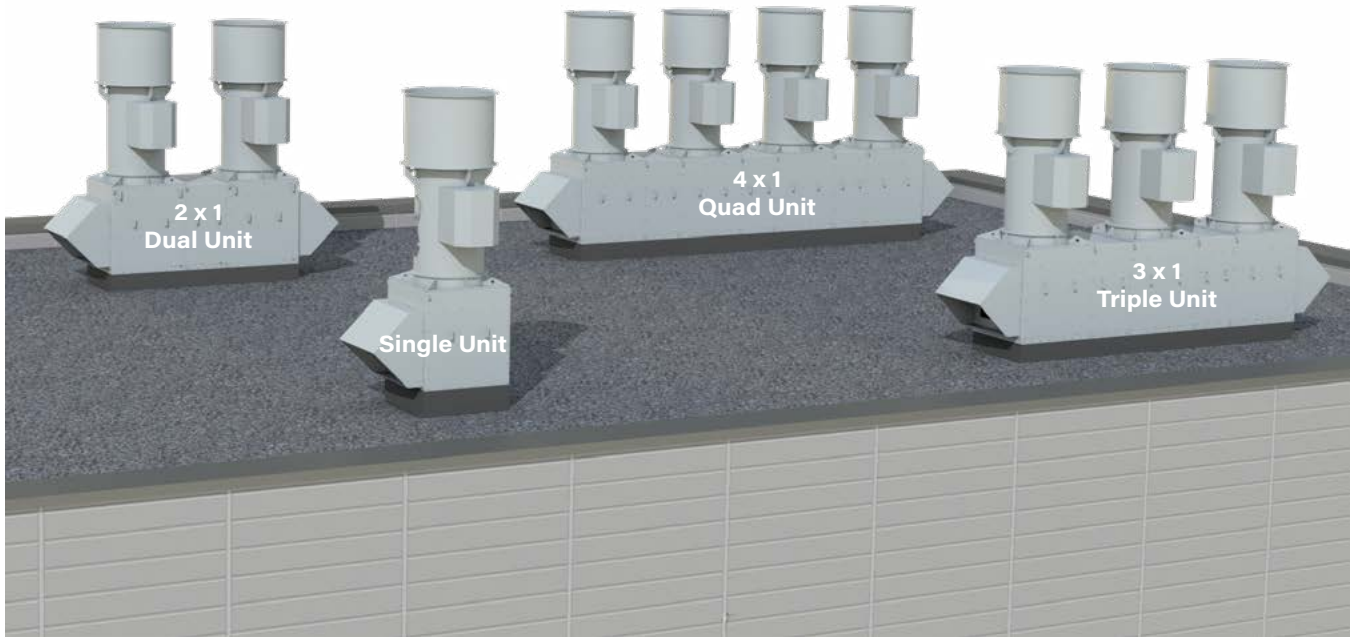

Unique applications require unique configurations. With the Twin City Fan & Blower Modular Mixing Box, multiple configurations are able to be easily created and retrofitted.



INSTALLATION PHOTOS



General Lab Exhaust



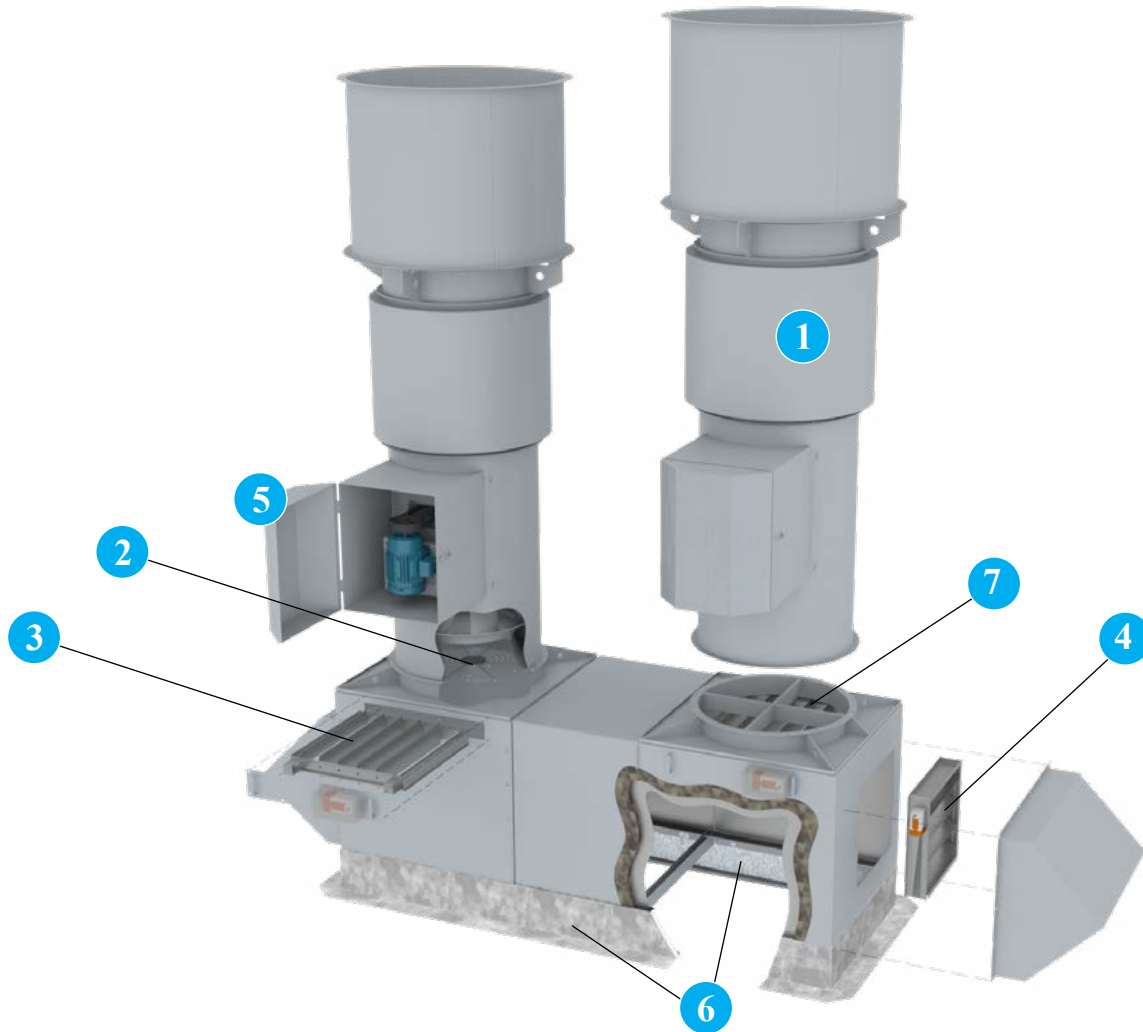

1 Outlet Silencer Designed to reduce noise of the fan system by attenuating sound at the fan outlet. Inclusion of the outlet silencer will void the 125 mph windload rating, it is recommended to use guy-wires for stability. Varying lengths and construction types are available.

2 Inlet Safety Screens can be provided for installation in the fan inlet.

3 Isolation Dampers are typically used on multi-fan systems to isolate individual fans. Isolation dampers are available with 2-position, spring-return controls and various materials of construction and coating options.

4 Bypass Damper are used to maintain outlet velocities by allowing a constant volume at the fan when exhaust air is reduced. Bypass dampers are available with either a manual, locking quadrant (handle) or with electrical controls and various materials of construction and coating options.

5 Hinged Weather Cover Weather covers on belt driven fans are easily removed for maintenance. To remove the cover without the use of tools, a two-piece hinged clamshell type weather cover is also available.

6 Insulated Roof Curb Standard roof curbs are 12" high and are constructed of heavy-duty galvanized steel and include 1½" thick insulation. Contact factory for other roof curb options. Note: 125 mph windload ratings require a Twin City Fan & Blower supplied roof curb. Parallel backdraft dampers are available for mounting in roof curbs.

7 Vortex Breaker Installed in the mixing plenum box at the fan inlet, the vortex breaker allows for even loading of the fan impeller and minimizes air 'swirl'. The vortex breaker is required with all side intake mixing plenum box configurations.



Units can be ordered as single fans without mixing plenum boxes.

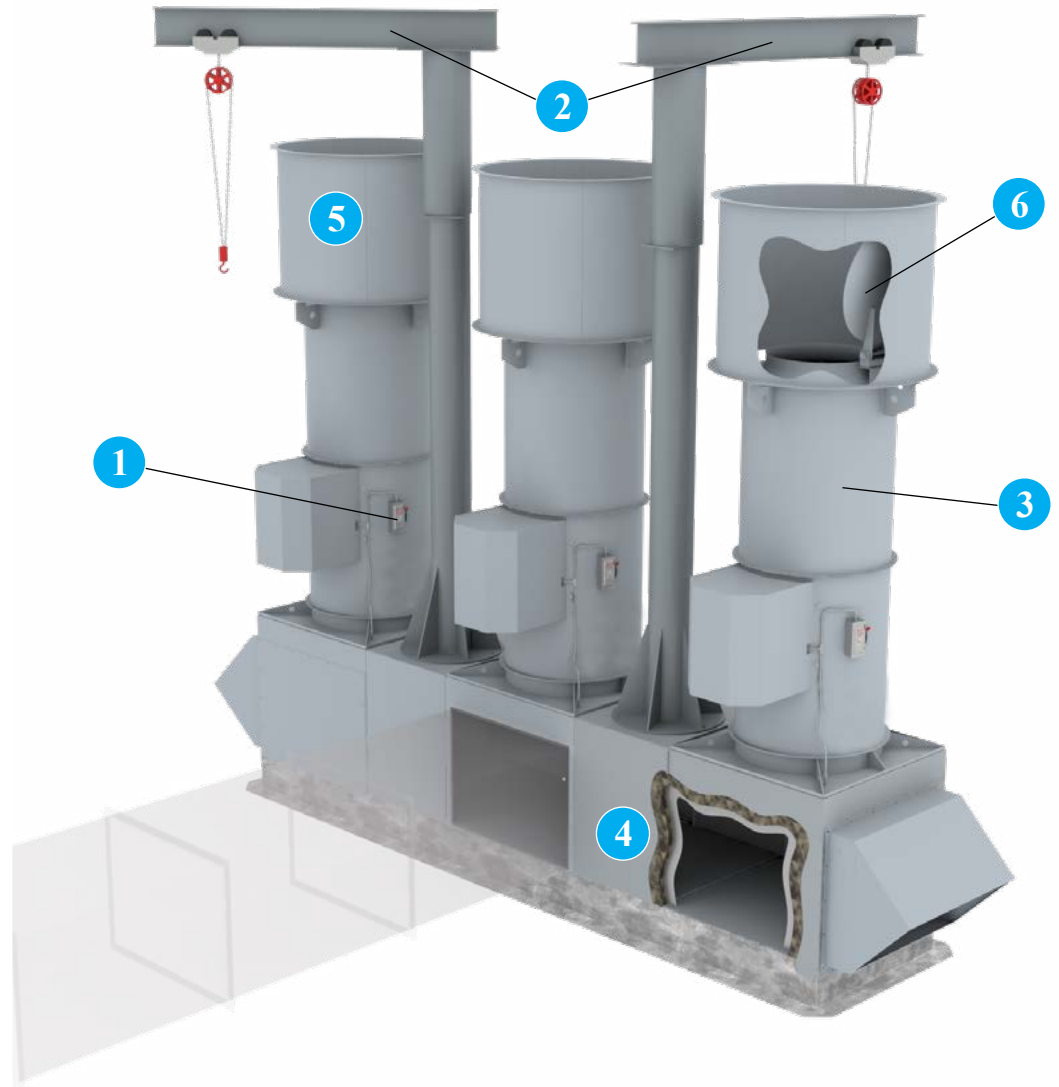

1 NEMA 3R Disconnect Switch, rain proof, disconnect is available shipped loose for field mounting and wiring or factory mounted and wired. Also available with a NEMA 4/4X or 7/9 switch.

2 Jib Crane Heavy-duty jib crane is designed to handle the weight of the heaviest individual component. The mount is connected to the specially reinforced mixing box spacer mixing box structure. Single and double mixing boxes receive one (1) jib crane. 3x1 and 4x1 configurations receive two (2) jib cranes.

3 Stack Extension Additional spool section can be provided to reach a minimum 10 foot stack height above the roof line.

4 Mixing Plenum Box w/ Weather Hood; Side Intake The mixing plenum box features modular construction allowing for multiple configurations and effortless retrofitting. Bottom intake is standard, side intake option available upon request.

5 Windband Constructed of heavy-gauge steel for strength and rigidity, the windband allows the plume to fully develop and protects the positive shut-off damper. The windband is directly mounted to the fan housing.

6 Positive Shut-off Damper The positive shut-off damper eliminates the chance of rain ingress by sealing the internal components of the fan from the elements when the fan is not in operation. The hinge is offset to ensure that a full plume develops to meet ANSI Z9.5 requirements.

OTHER ACCESSORIES:

- Piezometer Ring
- Pressure Transducer Transmitter w/ and w/o Display
- Manual Locking Quadrant Adder



Self-Flashing Roof Curbs

- When mounting the TFE to this roof curb, a 125 mph windload rating is guaranteed.
- Standard roof curb height is 12". Optional heights are also available.
- Curbs are constructed of 10-gauge galvanized steel with continuous welded seams.
- Damper shelf is standard.
- Self-flashing roof curbs allow for field supplied cants and roofing material to be brought up to the top of the curb.
- The roof curb is mounted directly onto the steel or concrete roof structure so the curb cap or mixing plenum box (if selected) will fit over the roof curb and secured per Twin City Fan's IOM.



Disconnect switches provide positive electrical shutoff during fan cleaning or maintenance.

NEMA 3R Disconnect Switch

A NEMA 3R, rain proof, disconnect is available shipped loose for field mounting and wiring or factory mounted and wired externally.



NEMA 3R Disconnect Switch

NEMA 4/4X Disconnect Switch

A NEMA 4, water and dust tight, disconnect is available shipped loose for field mounting and wiring or factory mounted and wired externally.

A NEMA 4X has the same level of protection against water and dust as NEMA 4 but is also corrosion resistant. Construction is either of aluminum or stainless steel.



NEMA 4 Disconnect Switch

NEMA 7/9 Disconnect Switch

A NEMA 7/9 disconnect switch (not pictured) is recommended on fans with explosion proof motors. The NEMA 7/9 switch is designed for use with fans operating in hazardous environments. Available shipped loose for field mounting and wiring.



NEMA 4X Disconnect Switch

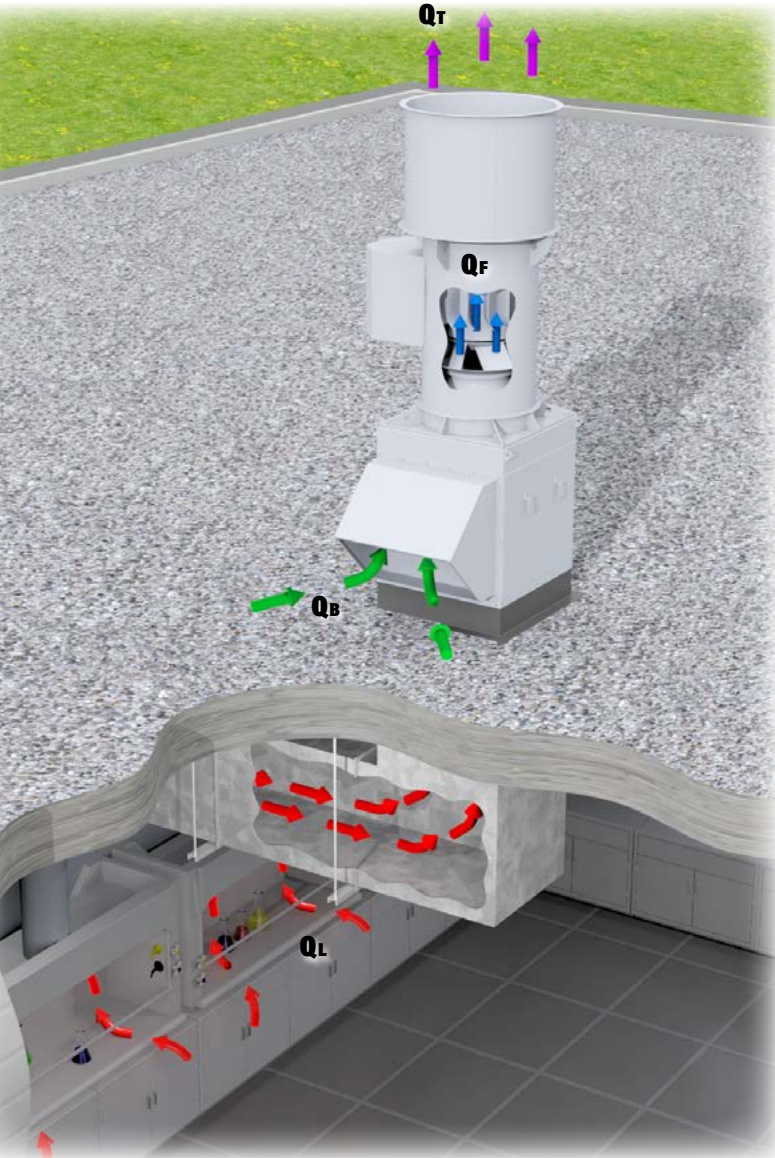

QB = Bypass Flow

QF = Fan Flow

QL = Laboratory Flow (Contaminated Air)

QT = Total Flow

$$Q_T = Q_B + Q_L$$

$$Q_F = Q_B + Q_L$$

Bypass Air

Ambient air that is drawn through the bypass air plenum and mixed with the lab exhaust to increase dilution and plume rise. Bypass air is primarily used in variable volume applications to maintain a constant discharge volume.

Fume Exhaust

Caustic or noxious air that is being exhausted from laboratory or fume hood.

Nozzle

Device located internal to the fan windband, causing the fume exhaust air to accelerate upon entrance to the windband. A wide range of nozzles from 4" in diameter to 60" in diameter is available to provide a wide range of high outlet velocities. Each nozzle provides different flow characteristics. Nozzle should be selected based on the application requirements.

Plume Rise

The height of the fume exhaust and bypass air above the discharge of the windband.

Plume Height

Overall height of the discharge plume rise, plus the added height of the exhaust system above the roof-deck level. (See diagram on page 11).

Total Airflow

The total airflow exiting the windband, including fume exhaust and bypass air.

Windband

Device used to direct the fume exhaust and allow the plume to properly develop as it leaves the housing of the exhaust fan.



$$h_e = h_r + h_s^*$$

$$h_e = [3.0 \times (V \times d/U)] + h_s$$

- h_e = Effective plume height (ft)
- h_r = Plume rise (ft)
- h_s = Stack height (height from roof to outlet of windband) (ft)
- V = Windband exit velocity (ft/min)
- d = Windband outlet diameter (ft)
- U = Crosswind speed (ft/min)

* Equation taken from ASHRAE Laboratory Design Guide, Equation 9-2.
 Note: Plume height calculations are typically calculated with a 10 mph (880 ft/min) crosswind.

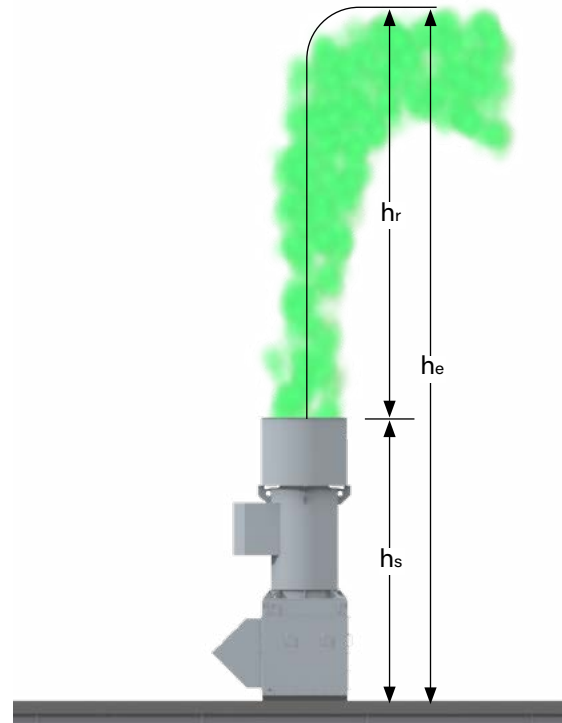

Available Nozzle Sizes

FAN SIZE	4	5	6	7	8	10	11	12	13	15	16	18	20	22	24	27	30	33	37	40	44	50	54	60
90	X	X	X	X	X																			
105		X	X	X	X																			
122			X	X	X	X	X	X	X															
150					X	X	X	X	X	X	X													
182					X	X	X	X	X	X	X	X	X											
200						X	X	X	X	X	X	X	X	X										
222						X	X	X	X	X	X	X	X	X	X									
245									X	X	X	X	X	X	X	X								
270										X	X	X	X	X	X	X	X							
300										X	X	X	X	X	X	X	X	X						
330												X	X	X	X	X	X	X	X					
365												X	X	X	X	X	X	X	X	X	X			
402														X	X	X	X	X	X	X	X	X		
445															X	X	X	X	X	X	X	X	X	
490																X	X	X	X	X	X	X	X	X
542																	X	X	X	X	X	X	X	X

Maximum RPM, Impeller Weights and WR² (Moment of Inertia)

FAN SIZE	CLASS I			CLASS II		
	MAX. RPM	WEIGHT LB.	WR ² LB-FT ²	MAX. RPM	WEIGHT LB.	WR ² LB-FT ²
90	3637	3.61	0.27	-	-	-
105	3637	3.39	0.25	-	-	-
122	3583	14	1.78	4676	19	2.64
150	2927	20	4.27	3819	26	5.84
182	2237	32	9.3	2917	36	10
200	2042	38	13	2662	41	14
222	1835	62	23	2393	62	23
245	1667	74	35	2173	74	35
270	1486	86	51	1938	86	51
300	1338	101	77	1745	119	95
330	1216	123	114	1586	144	134
365	1081	157	185	1410	181	216
402	981	194	273	1279	216	321
445	887	274	430	1157	328	563
490	806	317	622	1051	384	822
542	728	411	1060	949	480	1237

Bare Fan Weights

FAN SIZE	CLASS I	CLASS II
90	451	-
105	451	-
122	440	460
150	487	507
182	537	564
200	641	674
222	681	717
245	740	781
270	835	884
300	1180	1238
330	1034	1135
365	1274	1399
402	1546	1560
445	1823	1841
490	2231	2240
542	2765	2784

Nozzle Outlet Areas

NOZZLE SIZE	OUTLET AREA (SQ. FT.)
4	0.099
5	0.136
6	0.20
7	0.24
8	0.39
10	0.54
11	0.64
12	0.81
13	0.98
15	1.20
16	1.43
18	1.78
20	2.15
22	2.61
24	3.31
27	3.90
30	4.79
33	5.80
37	7.39
40	8.95
44	10.75
50	13.57
54	16.16
60	19.83

Note: Weights do not include motor, drive, mixing plenum box or roof curb weights. See table below for mixing plenum box weights. Values do not include the weight the optional stack extension.

Mixing Plenum Box Weight (lb)

FAN SIZE	SINGLE	DOUBLE	TRIPLE	QUAD
90 & 105	342	705	1085	1465
122	342	705	1085	1465
150	439	905	1393	1881
182	506	1062	1644	2226
200	519	1109	1725	2341
222	738	1590	2479	3368
245	926	1973	3067	4161
270	952	2069	3233	4398
300	1135	2450	3821	5192
330	1320	2823	4392	5961
365	1449	3113	4850	6586
402	1588	3422	5336	7249
445	1814	3891	6058	8225
490	1999	4309	6719	9129
542	2208	4775	7453	10130



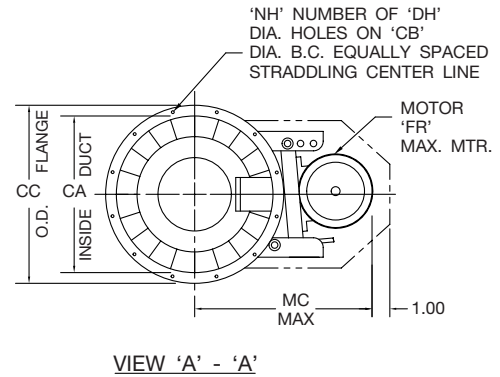
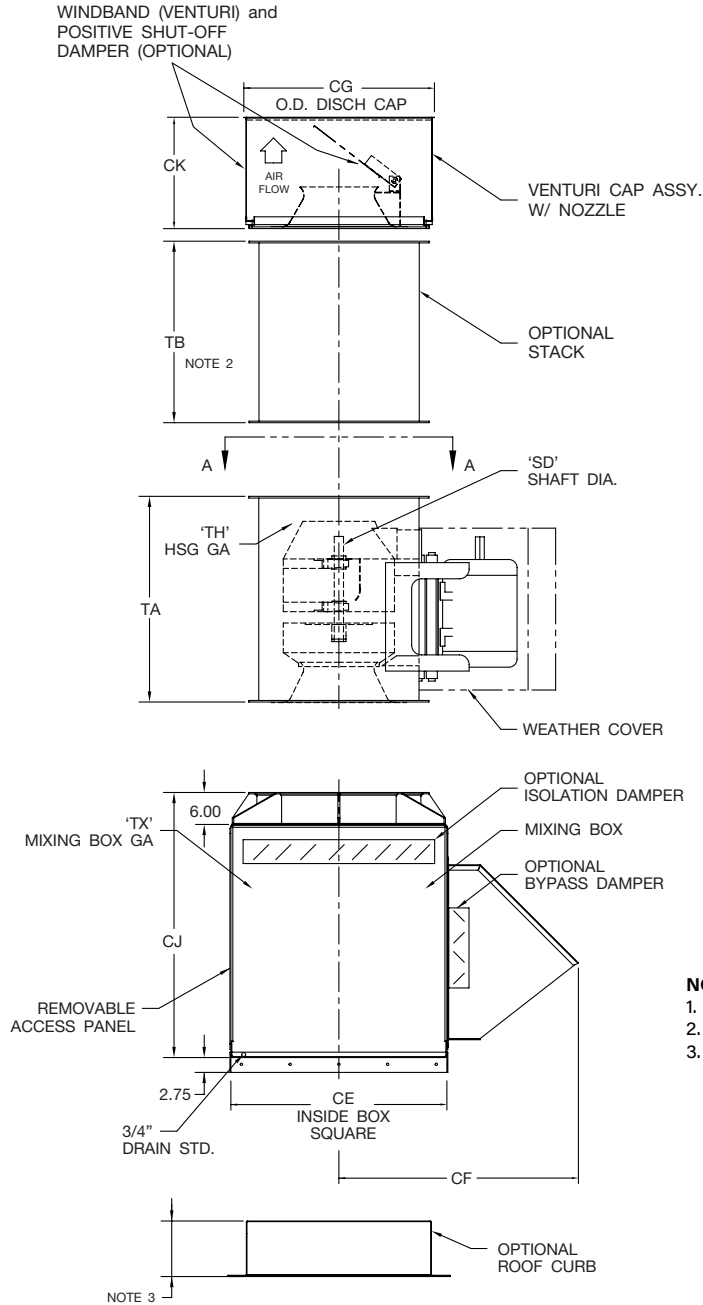

NOTES:

1. Standard TFE fan includes weather cover, access door and shaft seal.
2. Optional stack section can be added to increase overall height.
3. Standard curb height is 12", also available with 18" and 8".

FAN SIZE	CA	CB	CC	CE	CF	CG	CJ	CK	DH	FR	MC	NH	SD		TA	TB	TH	TX
													CLASS I	CLASS II				
90	16.13	17.88	19.63	28.00	32.13	27.00	37.00	22.38	0.56	145T	21.00	8	0.75	1	28.37	36.00	12	10
105	16.13	17.88	19.63	28.00	32.13	27.00	37.00	22.38	0.56	145T	21.00	8	0.75	1	28.37	36.00	12	10
122	16.56	18.50	19.75	28.00	32.13	29.00	37.00	20.63	0.56	184T	23.13	8	1	1	34.39	33.00	10	10
150	20.25	22.13	23.38	33.00	37.13	33.00	42.00	23.88	0.56	215T	25.75	8	1	1.187	40.88	22.00	10	10
182	24.69	26.75	28.00	36.00	40.13	37.00	45.00	28.38	0.69	256T	34.44	12	1.187	1.437	44.88	11.00	12	10
200	27.06	29.13	30.31	37.00	41.13	40.00	46.00	30.88	0.81	256T	36.25	12	1.437	1.437	49.41	8.00	12	10
222	30.06	32.13	33.38	40.00	44.13	43.00	49.00	33.88	0.81	286T	39.19	12	1.437	1.437	55.09	-	12	7
245	33.13	35.13	36.38	46.00	50.13	46.00	55.00	36.88	0.81	365T	43.63	12	1.437	1.937	61.99	-	12	7
270	36.50	38.50	39.75	47.00	51.13	50.00	56.00	40.13	0.81	365T	46.44	12	1.687	1.937	67.35	-	12	7
300	40.56	43.13	44.88	53.00	56.13	53.00	60.00	43.88	0.81	365T	49.38	16	1.937	2.187	74.84	-	10	7
330	44.63	47.25	49.00	60.00	59.63	58.00	60.00	52.38	0.81	365T	50.81	16	1.937	2.187	82.35	-	10	7
365	49.38	52.00	53.75	65.00	62.13	69.00	60.00	61.38	0.81	365T	53.75	16	1.937	2.437	91.46	-	10	7
402	54.38	57.50	59.75	71.00	65.13	69.00	60.00	61.38	0.81	405T	61.77	16	2.187	2.437	100.71	-	10	7
445	60.19	63.25	65.50	80.00	69.63	75.00	60.00	67.63	0.81	445T	66.72	16	2.437	2.687	111.76	-	10	7
490	66.25	69.38	71.63	87.00	73.13	81.00	60.00	73.13	0.81	445T	70.18	24	2.687	2.937	122.88	-	10	7
542	73.38	77.00	79.75	95.00	77.13	88.00	60.00	80.13	0.81	445T	74.01	24	2.937	3.437	136.04	-	10	7

DIMENSIONS SUBJECT TO CHANGE. CERTIFIED DRAWINGS AVAILABLE UPON REQUEST.

BC1003181C
BC1004891B



Model TFE

Model TFE High Velocity Fume Exhaust Fan, where indicated on drawings and schedules, shall be of the non-overloading design, and shall be of the size and capacity as indicated in the fan schedule. High Velocity Fume Exhaust Fans shall be as manufactured by Twin City Fan and Blower, Minneapolis, Minnesota.

PERFORMANCE — Fans shall be tested in accordance with AMCA test codes for air moving devices and shall be guaranteed by the manufacturer to deliver rated published performance levels. Model TFE shall be licensed to bear the AMCA certified ratings seal for air and sound, and fan energy index (FEI). Sound certification shall apply to both inlet and outlet sound power levels. Model TFE shall be UL/cUL 705 listed for electrical.

Fans shall be designed for maximum efficiency. Fans shall have a sharply rising pressure characteristic extending through the operating range and continuing to rise well beyond the efficiency peak to assure quiet and stable operation under all conditions. Horsepower characteristics shall be truly self-limiting and shall reach a peak in the normal selection area.

HOUSING — Housings shall be cylindrical and welded steel throughout. Inlets shall be fully streamlined. Housings shall be suitably braced to prevent vibration or pulsation. Totally enclosed weather cover shall enclose motor and V-belt drives. Punched inlet flange shall be equipped for curb cap or mixing plenum box mounting. Extended lube lines shall be provided for ease of lubrication. Model TFE shall include outlet nozzle, windband, heavy-duty coated steel curb cap, access door, shaft seal and weather cover, and a sealed belt tube for the protection of belts and drive components from the airstream.

IMPELLER — Fan impellers shall have die-formed blades designed for maximum efficiency, and quiet and stable operation. Blades shall be continuously-welded to the back plate and impeller front plate. Impellers shall be statically and dynamically balanced and the complete fan assembly including motor and drive shall be test balanced at or near the operating speed at the factory prior to shipment.

SHAFT — Shafts shall be AISI 1040 or 1045 hot rolled steel, accurately turned, ground, polished and ring-gauged for accuracy. Shafts shall be sized for the first critical speed of at least 1.43 times the maximum speed.

BEARINGS — Bearings shall be heavy-duty, grease lubricated, anti-friction ball or roller, self-aligning, pillow block type and selected for a minimum L-10 life of 200,000 hours at the maximum fan RPM. Bearings shall be equipped with extended lubrication lines with grease fittings outside of the fan housing.

DRIVE — Motor sheaves shall be cast iron, variable pitch on applications 10 HP and smaller, and fixed pitch on 15 HP and larger. Drives shall be sized for at least 200% of motor horsepower.

CURB CAP — A heavy-duty, coated steel or galvanized curb cap shall be included to provide for a weather-tight transition between the roof curb and the fan.

NOZZLE AND WINDBAND — A nozzle and windband combination shall be provided to efficiently increase discharge velocities to be a recommended minimum of 3,000 FPM without significantly affecting BHP requirements.

WEATHER COVER — A raintight, easily removable weather cover shall be provided to completely enclose the motor and exposed parts of the V-belt drive.



Model

TFE (cont'd)

OPTIONAL ACCESSORIES — Where required the fans shall be provided with:

- AMCA "B" or "C" spark resistant construction
- Modular mixing plenum box
- Bypass damper with actuator
- Isolation damper with actuator
- Disconnect switches
- Roof curb
- Vortex breaker
- Windband
- Shut-off damper
- Special coatings on airstream parts or entire unit
- Special materials of construction
- Stack extension to reach ten feet from roof line

SUBMITTALS — Submittals for approval of equipment shall include copies of outline drawings, AMCA Certified Ratings and percentage pressure-volume performance curves showing point of operation.



INDUSTRIAL PROCESS AND COMMERCIAL VENTILATION SYSTEMS

CENTRIFUGAL FANS | UTILITY SETS | PLENUM & PLUG FANS | INLINE CENTRIFUGAL FANS
MIXED FLOW FANS | TUBEAXIAL & VANEAXIAL FANS | WALL MOUNTED FANS | ROOF VENTILATORS
CENTRIFUGAL ROOF & WALL EXHAUSTERS | CEILING VENTILATORS | GRAVITY VENTILATORS | DUCT BLOWERS
RADIAL BLADED FANS | RADIAL TIP FANS | HIGH EFFICIENCY INDUSTRIAL FANS | PRESSURE BLOWERS
LABORATORY EXHAUST FANS | FILTERED SUPPLY FANS | MANCOOLERS | FIBERGLASS FANS | CUSTOM FANS



TWIN CITY FAN & BLOWER
WWW.TCF.COM

5959 TRENTON LANE N. | MINNEAPOLIS, MN 55442 | PHONE: 763-551-7600 | FAX: 763-551-7601

©1999-2024 Twin City Fan Companies, Ltd., Minneapolis, MN. All rights reserved. Catalog illustrations cover the general appearance of Twin City Fan & Blower products at the time of publication and we reserve the right to make changes in design and construction at any time without notice.