



ADJUSTABLE PITCH ANGLE AXIAL FAN

Vane Axial



GTG Industries Sdn Bhd certifies that the model: TFA/V shown herein is licensed to bear the AMCA Seal. The ratings shown are based on tests and procedures performed in accordance with AMCA Publication 211 and AMCA Publication 311 and comply with the requirements of the AMCA Certified Ratings Program.

Table of Contents

• Standard Features	02
• Adjustable Pitch Axial Fans - V Series	03
• Series TFA 630 / 250 / 14 / V / 2880rpm	04
• Series TFA 630 / 250 / 14 / V / 1440rpm	05
• Series TFA 630 / 250 / 14 / V / 960rpm	06
• Series TFA 630 / 250 / 14 / V / 720rpm	07
• Series TFA 800 / 250 / 14 / V / 2880rpm	08
• Series TFA 800 / 250 / 14 / V / 1440rpm	09
• Series TFA 800 / 250 / 14 / V / 960rpm	10
• Series TFA 800 / 250 / 14 / V / 720rpm	11
• Series TFA 800 / 350 / 12 / V	12
1440rpm	
960rpm	
720rpm	
• Series TFA1000 / 300 / 10 / V	13
• Series TFA 1000 / 350 / 12 / V / 1440rpm	14
• Series TFA 1000 / 350 / 12 / V / 960rpm	15
• Series TFA 1000 / 350 / 12 / V / 720rpm	16
• Series TFA 1120 / 300 / 10 / V	17
• Series TFA 1120 / 350 / 12 / V	18
• Series TFA 1250 / 350 / 12 / V / 1440rpm	19
• Series TFA 1250 / 350 / 12 / V / 960rpm	20
• Series TFA 1250 / 350 / 12 / V / 720rpm	21
• Series TFA 1400 / 350 / 12 / V / 1440rpm	22
• Series TFA 1400 / 350 / 12 / V / 960rpm	23
• Series TFA 1400 / 350 / 12 / V / 720rpm	24
• Series TFA 1400 / 350 / 12 / V / 580rpm	25
• Series TFA 1400 / 420 / 11 / V / 1440rpm	26
• Series TFA 1400 / 420 / 11 / V / 960rpm	27
• Series TFA 1400 / 420 / 11 / V / 720rpm	28
• Series TFA 1400 / 420 / 11 / V / 580rpm	29
• Series TFA 1600 / 420 / 11 / V / 1440rpm	30
• Series TFA 1600 / 420 / 11 / V / 960rpm	31
• Series TFA 1600 / 420 / 11 / V / 720rpm	32
• Series TFA 1600 / 420 / 11 / V / 580rpm	33
• TFA V Series Dimensions	34

Standard Features

- A** High static pressure
- B** High air volume
- C** High efficiency with low energy consumption
- D** Uniquely designed guide vanes
- E** Aerofoil impeller featured with adjustable pitch angle
- F** Precision die cast Aluminium hub and blades
- G** High Strength and rigidity spun flanges design
- H** Terminal box in IP 55 mounted externally on casing for easy wiring connection
- I** Equipped with single or three-phase motor in IP 55 and class F insulation



Exova Warringtonfire Aus Pty Ltd
Level 2, 409-411 Hammond Road, Mandaring VIC 3175
Australia
T: +61 (0)3 917 1000
E: info@exova.com.au
www.exova.com

Postal Address:
PO Box 4302
Caulfield East, Victoria 3104
Australia
Testing, Advising, Assuring

EXOVA
Warringtonfire

EWFA CERTIFICATE OF TEST		CERTIFICATE No : SFC 2144500a.6	Page 1 of 1
Report Sponsor		Certificate Issue Date	
GTG Industries Sdn. Bhd. 26-2, 1st Floor, Jalan PUJ 3/38A, Sunway Damansara Technology Park, 47810 Petaling Jaya, Selangor.		03/04/2013	
Introduction			
The element of construction described below was tested by this laboratory on behalf of the test sponsor in accordance with the stated test standard and achieved the results stated below. Refer to the referenced test report for further information.			
Referenced Reports	Report Date	Test Standard	Significant Variations from standard test procedures and conditions
WFRFA 2144500a.1	24/09/07	BS7346	None
Description of Test Specimen			
TEST ASSEMBLY - The test assembly comprised an electrically powered axial fan within a fan casing and installed within an instrumented section of duct. TEST SPECIMEN - The axial fan was a GTG Model No. TFA S1H powered by an electric motor contained within a fan casing of nominal ID 1200 mm. The fan impeller consisted of 4 aluminium blades with a pitch angle of 10° and a nominal clearance of 18 mm to the inside of the fan casing. The tested motor was a JEM Squirrel Cage Induction Motor 415 V / 50 Hz with a maximum FLC at ambient of 20.70 maximum rated speed was 1440 rpm. The frame size was ORIENTATION - The specimen was installed with the fan drawing air from the furnace over the electric motor. Refer to the full report, WFRFA 2144500a.1, for a complete description of the test specimen construction and significant behaviour.			
Test Results			
Structural	No failure at 120 minutes		
Electrical	No failure at 120 minutes		
Aerodynamic	No failure at 120 minutes		
Fire Rating Classification	B		
Noises			
THIS CERTIFICATE IS PROVIDED FOR GENERAL INFORMATION ONLY AND DOES NOT COMPLY WITH THE REGULATORY REQUIREMENTS FOR EVIDENCE OF COMPLIANCE. Reference should be made to the relevant test report to determine the applicability of the test result to a proposed installation. The results of these fire tests may be used to assess fire hazard but it should be recognised that a simple test method will not provide a full assessment of fire hazard under all conditions.			
TESTING AUTHORITY		Exova Warringtonfire Aus Pty Ltd	
Address		PO Box 4302, CAULFIELD EAST VIC 3104 Level 2, 409-411 Hammond Road, MANDARING VIC 3175 Australia T: +61 (0)3 917 1000 - F: +61 (0) 3 917 1001 E: info@exova.com.au www.exova.com	
Prepared By	Reviewed By:		
P. F. Mithran	John Hadden		

Smoke Spill Application

(on request)

The GTG TFA V Series can be used for smoke spill applications. The fan with class H insulation is capable of withstanding up to 250°C for 2 hours in accordance to BS7346 : Part 2, which was tested by Exova Warringtonfire Aus Pty Ltd

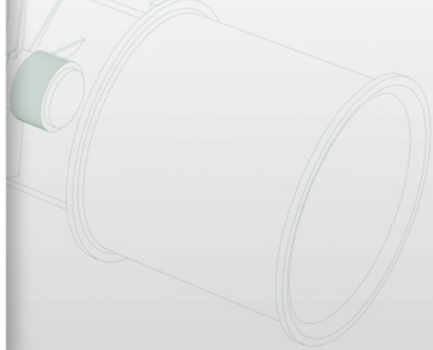

Adjustable Pitch Axial Fans V Series

GTG[®] fully adjustable pitch vane axial fans are available in various sizes from 630mm diameter up to 1400mm diameter. The V series comes with uniquely designed guide vanes that enable the fan to deliver high air volume for high pressure applications at high efficiency.

The wide range of fan diameters, various hub designs and blade configurations, different pitch angles and motor speeds allow accurate selection of the fan to match the specific duty.

Pitch angle adjustment can be readily carried out on site allowing the fan performance to be modified to the final system resistance.

Whilst the standard range of axial fan cover most applications, purposed designed casings and mountings are available.



Standard Product SPECIFICATION

Guide Vane

Multi vane section designed to serve as static regain device to ensure maximum efficiency in converting the velocity pressure to static pressure with minimal turbulence.

The function of the guide vanes is to improve the efficiency and the pressure characteristics by converting rotational energy at the propeller discharge into useful work.

Impellers

Precision cast aluminium adjustable pitch aerofoil blades are attached to injection cast aluminium hub, incorporate a taper lock bushing and keyed to the motor shaft for easy installation and removal.

Large hub to blade ratio prevents backflow of air and moves large volumes of air at high pressures.

Housings

Heavy gauge, mild steel casing, drum and rolled steel flanges finishes in hot-dipped galvanised (as standard) or epoxy powder coated (on request)

Motors

Motors are 415V / 3 Phase / 50Hz, foot mounted TEA) squirrel cage induction type with class F insulation.

Options are available for a varying range of applications including :

- Single phase
- Special frequency
- Explosion proof
- Speed control
- High temperature
- 2 speed
- Smoke spill
- Thermal overload protection
- Special voltage
- Special insulation

Product Identification

TFA 630/250/14/V-20

TFA	- Model Tube Axial
630	- Case Diameter
250	- Hub Diameter
14	- No. of Blades
V	- Vane Axial Series
20	- Blade angle

Options

- Inlet and discharge cones
- Inlet and discharge guards
- Flexible Connections
- Matching flanges
- Mounting feet
- Vibration isolation mounts
- Sound attenuators

SERIES TFA 630/250/14/V

Impeller Code : 630/250
 Size : 630mm
 Outlet Area : 0.312m²

Adjustable Pitch Angle Vane Axial Fan

FEG67

50Hz
2880 rpm

$\rho = 1.2\text{kg/m}^3$

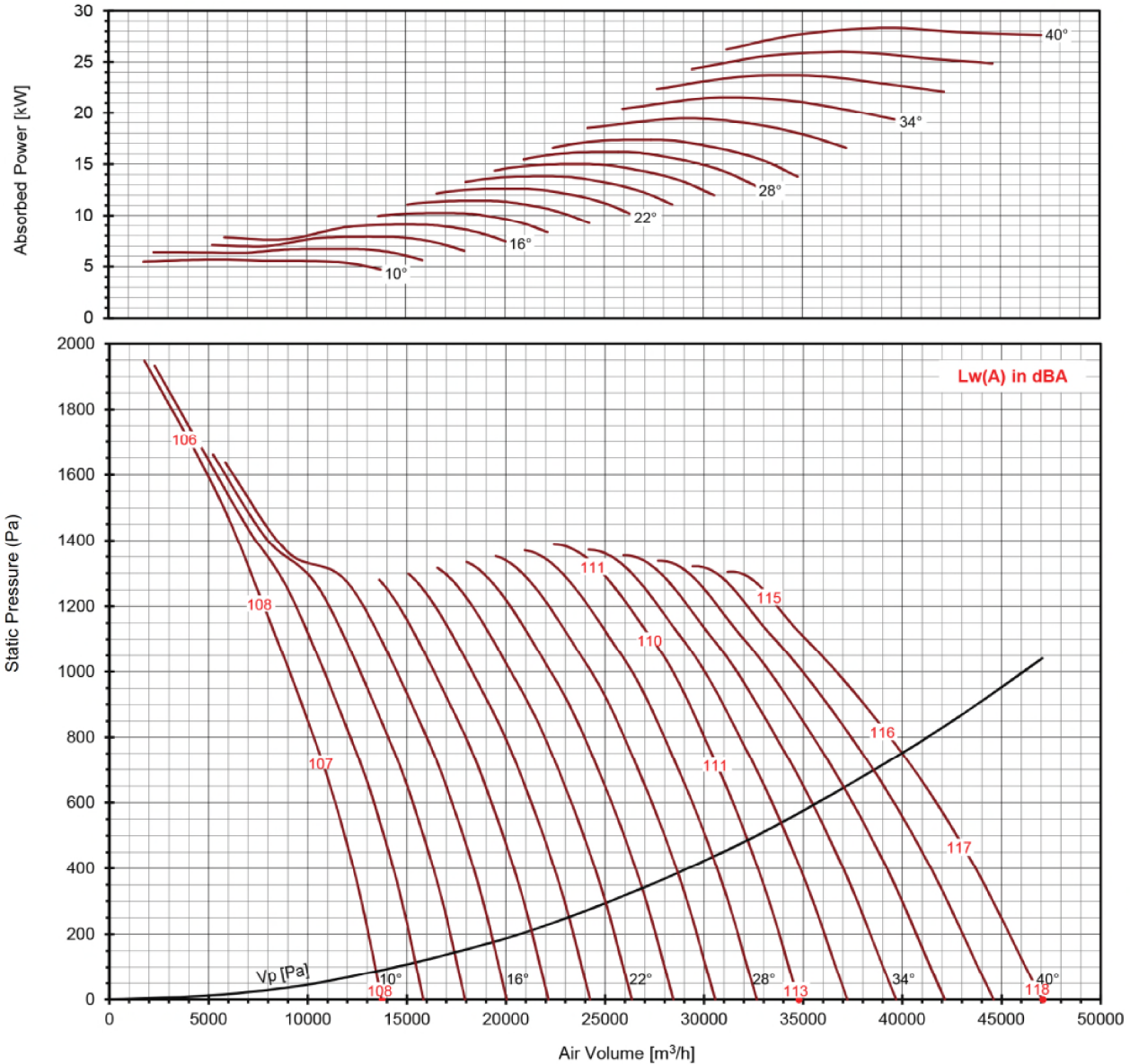

Peak Absorbed Power (kW)

N (rpm)	Blade Pitch Angle																Lp(A) at 3m
	10°	12°	14°	16°	18°	20°	22°	24°	26°	28°	30°	32°	34°	36°	38°	40°	
2880	5.67	6.69	7.88	9.06	10.25	11.44	12.62	13.81	14.99	16.18	17.37	19.43	21.50	23.63	25.98	28.34	-20
motor	7.5		11		15			18.5			22		30				

* Performance certified is for installation type D - Ducted Inlet, Ducted Outlet. Performance ratings do not include the effects of appurtenances (accessories).

* The A-weighted sound ratings shown have been calculated per AMCA International Standard 301. Values shown are for inlet LwiA sound power levels for installation type D: ducted inlet ducted outlet. Ratings include the effects of duct end correction.

* Lp(A) - dBA Levels are not licensed by AMCA International.



SERIES TFA 630/250/14/V

Impeller Code : 630/250
 Size : 630mm
 Outlet Area : 0.312m²

Adjustable Pitch Angle Vane Axial Fan

FEG67

50Hz
 1440 rpm

$\rho = 1.2\text{kg/m}^3$

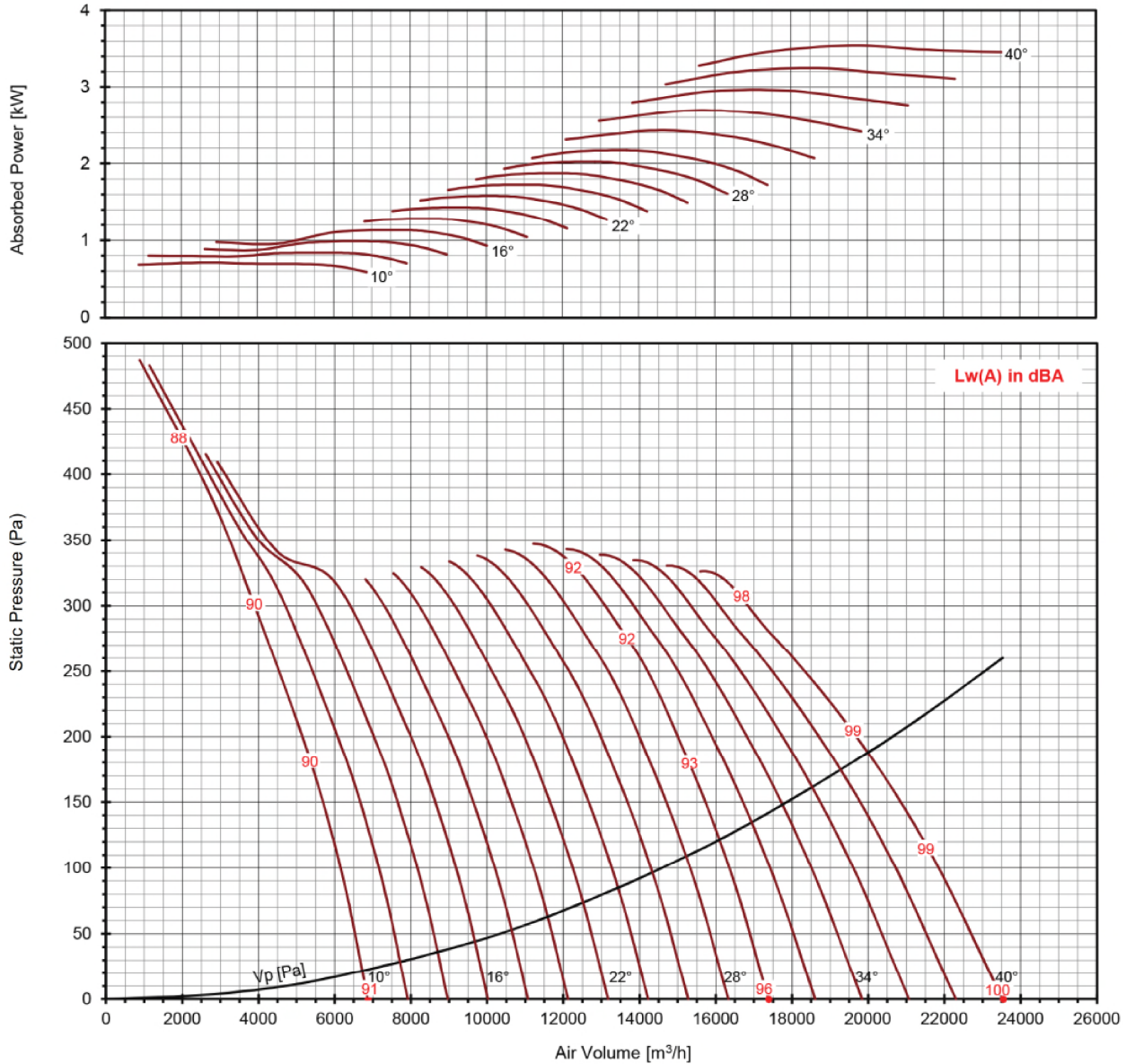

Peak Absorbed Power (kW)

N (rpm)	Blade Pitch Angle																Lp(A) at 3m
	10°	12°	14°	16°	18°	20°	22°	24°	26°	28°	30°	32°	34°	36°	38°	40°	
1440	0.709	0.836	0.985	1.133	1.281	1.430	1.578	1.726	1.874	2.023	2.171	2.429	2.687	2.954	3.248	3.542	-20
motor	0.75	1.1		1.5			2.2				3			4			

* Performance certified is for installation type D - Ducted Inlet, Ducted Outlet. Performance ratings do not include the effects of appurtenances (accessories).

* The A-weighted sound ratings shown have been calculated per AMCA International Standard 301. Values shown are for inlet LwA sound power levels for installation type D: ducted inlet ducted outlet. Ratings include the effects of duct end correction.

* Lp(A) - dBA Levels are not licensed by AMCA International.



SERIES TFA 630/250/14/V

Impeller Code : 630/250
 Size : 630mm
 Outlet Area : 0.312m²

Adjustable Pitch Angle Vane Axial Fan

FEG67

50Hz
960 rpm

$\rho = 1.2\text{kg/m}^3$

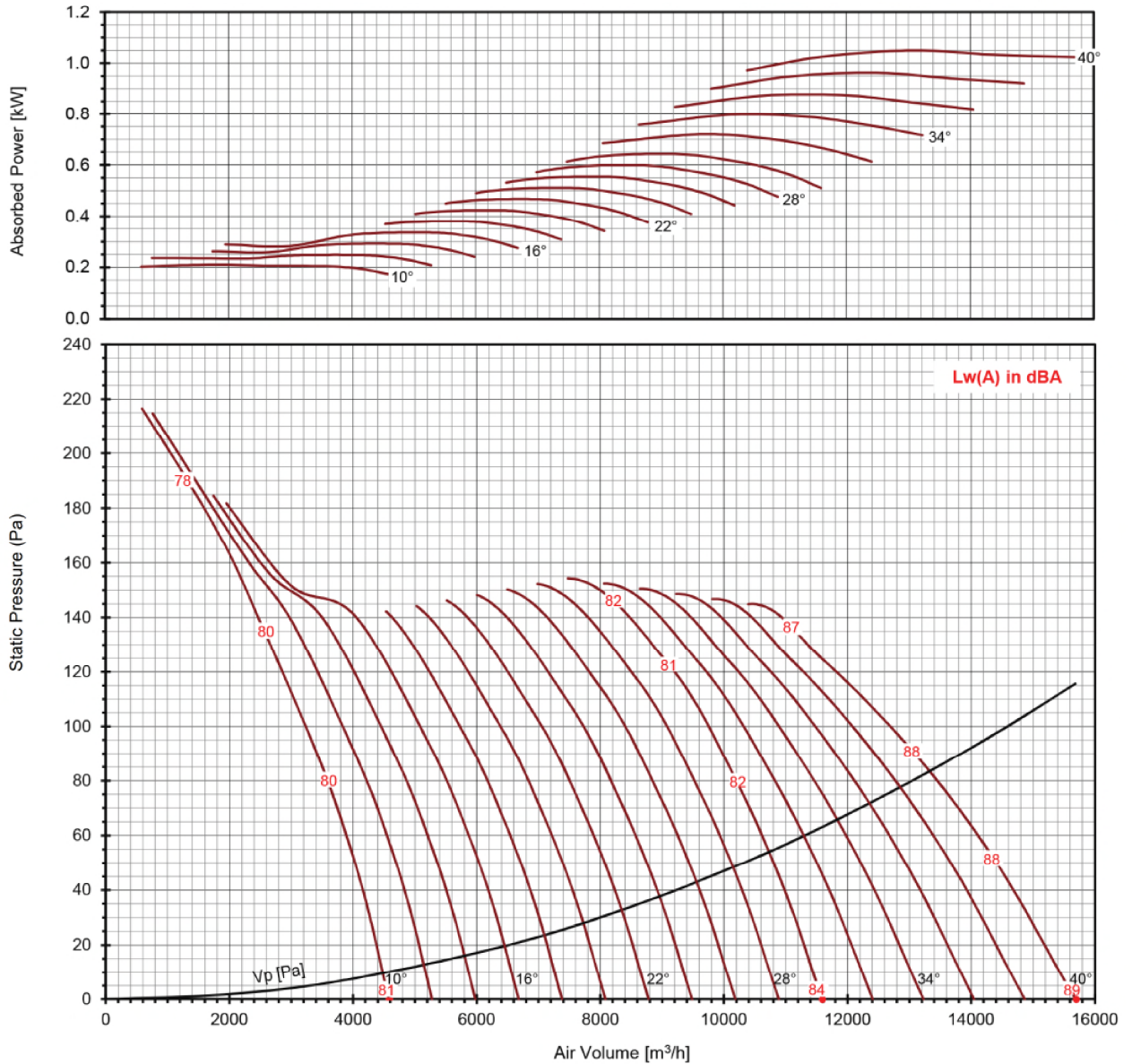

Peak Absorbed Power (kW)

N (rpm)	Blade Pitch Angle																Lp(A) at 3m
	10°	12°	14°	16°	18°	20°	22°	24°	26°	28°	30°	32°	34°	36°	38°	40°	
960 motor	0.210	0.248	0.292	0.336	0.380	0.424	0.468	0.511	0.555	0.599	0.643	0.720	0.796	0.875	0.962	1.049	-20

* Performance certified is for installation type D - Ducted Inlet, Ducted Outlet. Performance ratings do not include the effects of appurtenances (accessories).

* The A-weighted sound ratings shown have been calculated per AMCA International Standard 301. Values shown are for inlet LwA sound power levels for installation type D: ducted inlet ducted outlet. Ratings include the effects of duct end correction.

* Lp(A) - dBA Levels are not licensed by AMCA International.



SERIES TFA 630/250/14/V

Impeller Code : 630/250
 Size : 630mm
 Outlet Area : 0.312m²

Adjustable Pitch Angle Vane Axial Fan

FEG67

50Hz
 720 rpm

$\rho = 1.2\text{kg/m}^3$

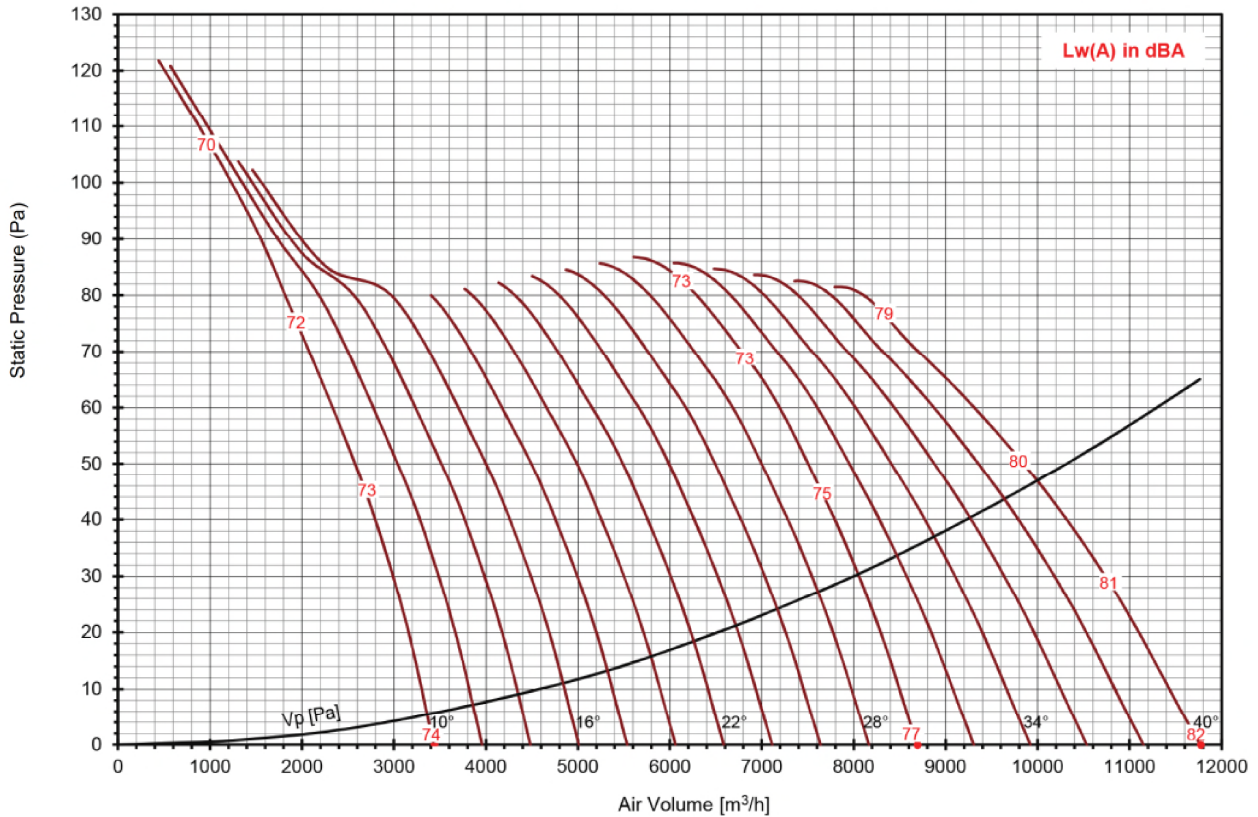
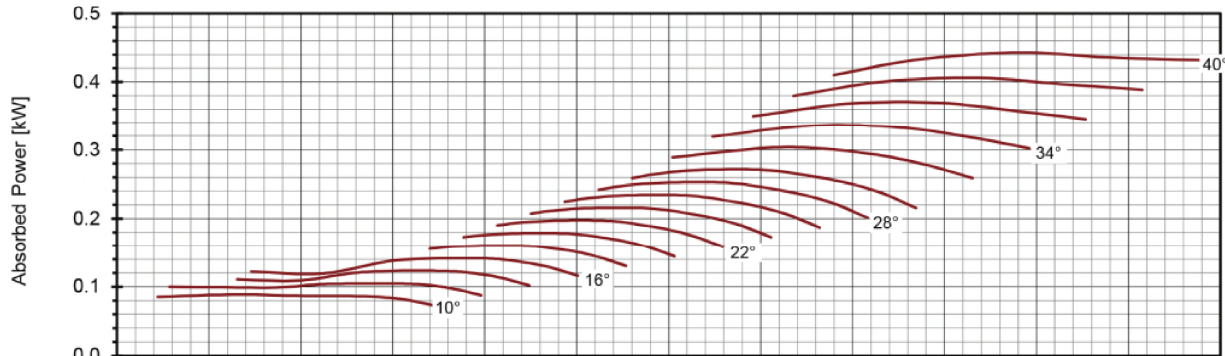

Peak Absorbed Power (kW)

N (rpm)	Blade Pitch Angle																Lp(A) at 3m
	10°	12°	14°	16°	18°	20°	22°	24°	26°	28°	30°	32°	34°	36°	38°	40°	
720 motor	0.089	0.105	0.123	0.142	0.160	0.179	0.197	0.216	0.234	0.253	0.271	0.304	0.336	0.369	0.406	0.443	20
									0.37				0.55				

* Performance certified is for installation type D - Ducted Inlet, Ducted Outlet. Performance ratings do not include the effects of appurtenances (accessories).

* The A-weighted sound ratings shown have been calculated per AMCA International Standard 301. Values shown are for inlet LwiA sound power levels for installation type D: ducted inlet ducted outlet. Ratings include the effects of duct end correction.

* Lp(A) - dBA Levels are not licensed by AMCA International.



SERIES TFA 800/250/14/V

Impeller Code : 800/250
 Size : 800mm
 Outlet Area : 0.503m²

Adjustable Pitch Angle Vane Axial Fan

FEG75

50Hz
2880 rpm

$\rho = 1.2\text{kg/m}^3$

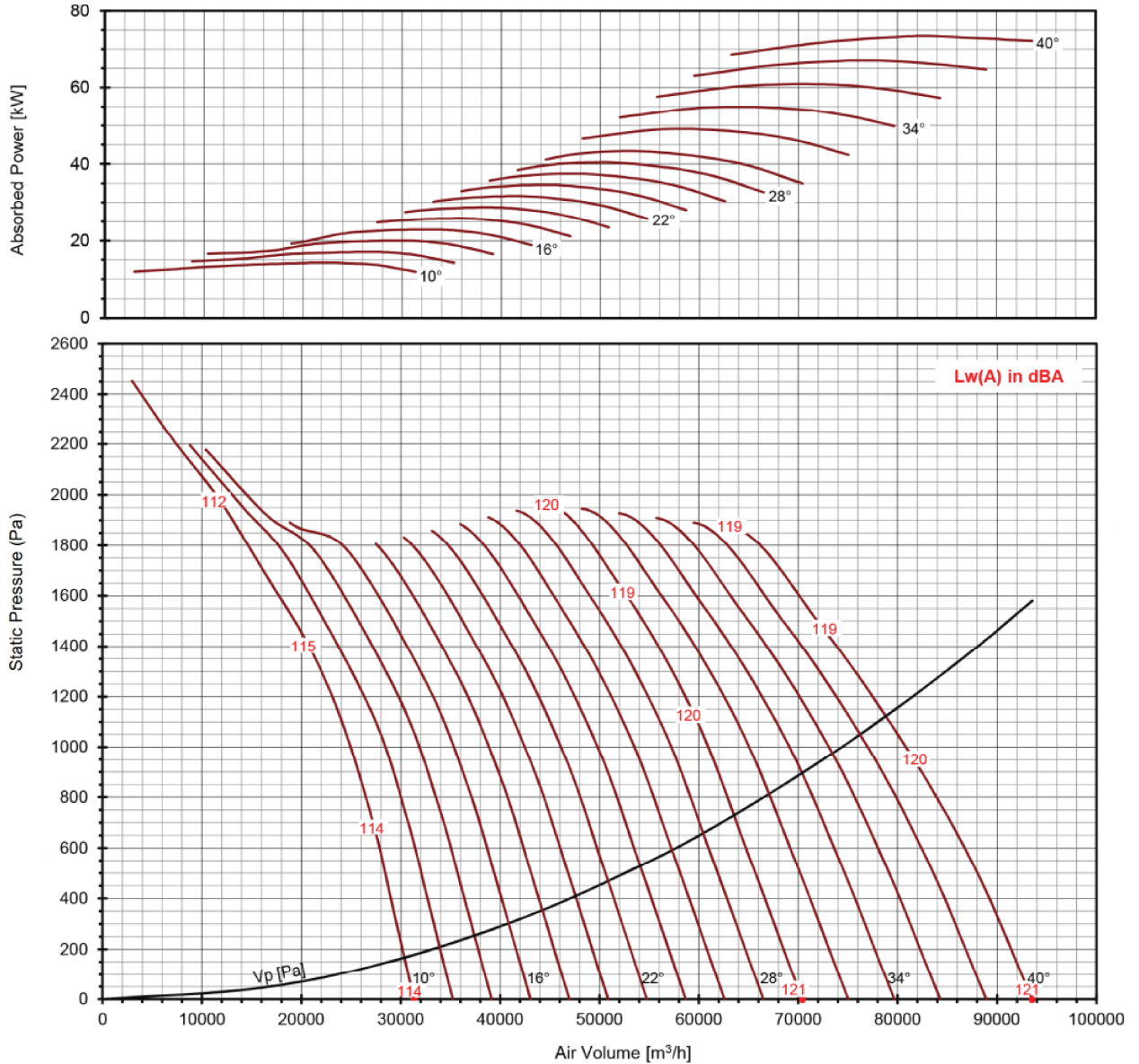

Peak Absorbed Power (kW)

N (rpm)	Blade Pitch Angle														Lp(A) at 3m		
	10°	12°	14°	16°	18°	20°	22°	24°	26°	28°	30°	32°	34°	36°		38°	40°
2880	14.2	17.1	20.0	22.9	25.8	28.8	31.7	34.7	37.5	40.4	43.3	49.0	54.7	60.9	67.1	73.4	-20
motor	15	18.5	22		30		37		45			55			75		

* Performance certified is for installation type D - Ducted Inlet, Ducted Outlet. Performance ratings do not include the effects of appurtenances (accessories).

* The A-weighted sound ratings shown have been calculated per AMCA International Standard 301. Values shown are for inlet LwA sound power levels for installation type D: ducted inlet ducted outlet. Ratings include the effects of duct end correction.

* Lp(A) - dBA Levels are not licensed by AMCA International.



SERIES TFA 800/250/14/V

Impeller Code : 800/250
 Size : 800mm
 Outlet Area : 0.503m²

Adjustable Pitch Angle Vane Axial Fan

FEG75

50Hz
1440 rpm

$\rho = 1.2\text{kg/m}^3$

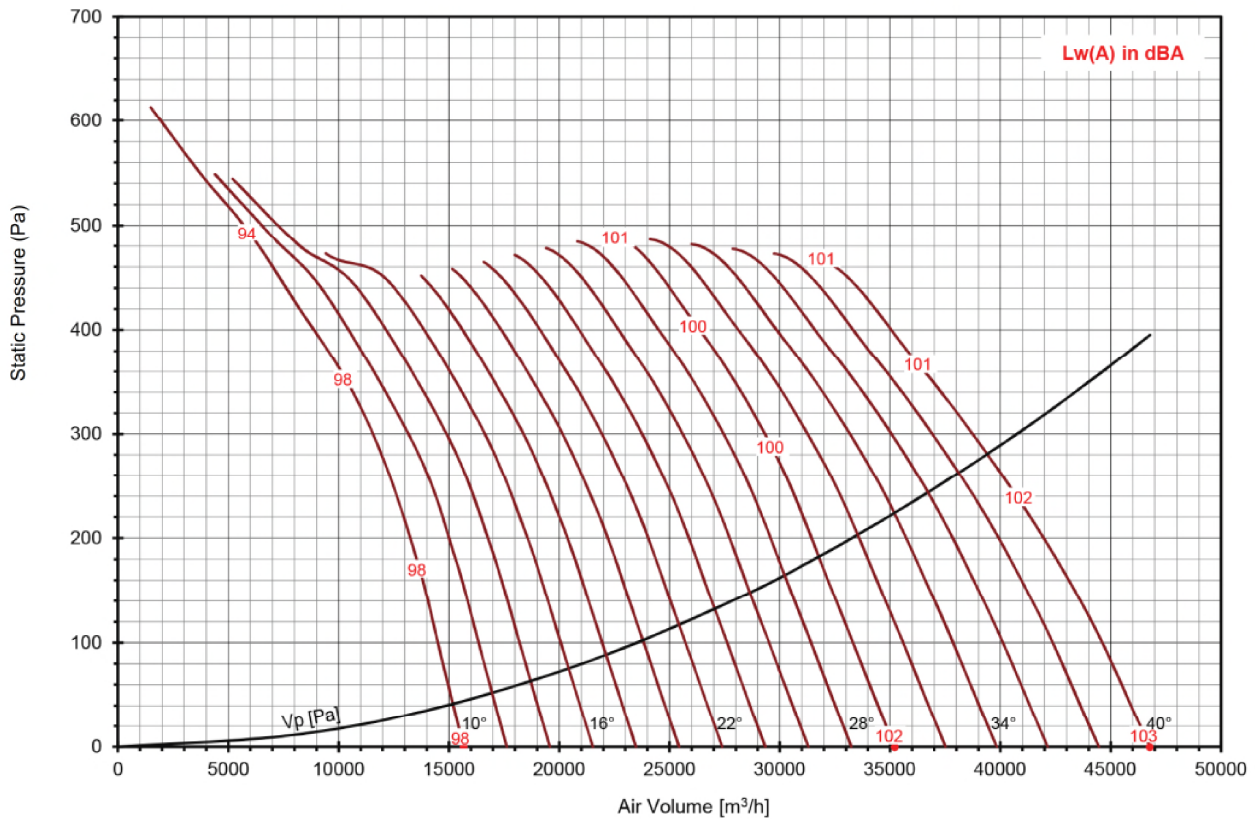
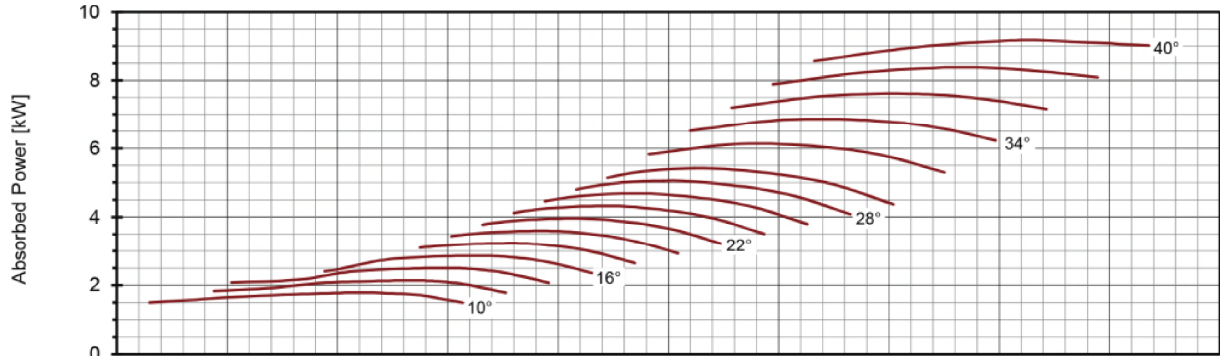

Peak Absorbed Power (kW)

N (rpm)	Blade Pitch Angle															Lp(A) at 3m	
	10°	12°	14°	16°	18°	20°	22°	24°	26°	28°	30°	32°	34°	36°	38°		40°
1440	1.78	2.14	2.50	2.86	3.23	3.59	3.96	4.33	4.69	5.05	5.42	6.13	6.84	7.61	8.39	9.17	-20
motor	2.2		3		4		5.5		7.5		11						

* Performance certified is for installation type D - Ducted Inlet, Ducted Outlet. Performance ratings do not include the effects of appurtenances (accessories).

* The A-weighted sound ratings shown have been calculated per AMCA International Standard 301. Values shown are for inlet LwiA sound power levels for installation type D: ducted inlet ducted outlet. Ratings include the effects of duct end correction.

* Lp(A) - dBA Levels are not licensed by AMCA International.



SERIES TFA 800/250/14/V

Impeller Code : 800/250
 Size : 800mm
 Outlet Area : 0.503m²

Adjustable Pitch Angle Vane Axial Fan

FEG75

50Hz
960 rpm

$\rho = 1.2\text{kg/m}^3$

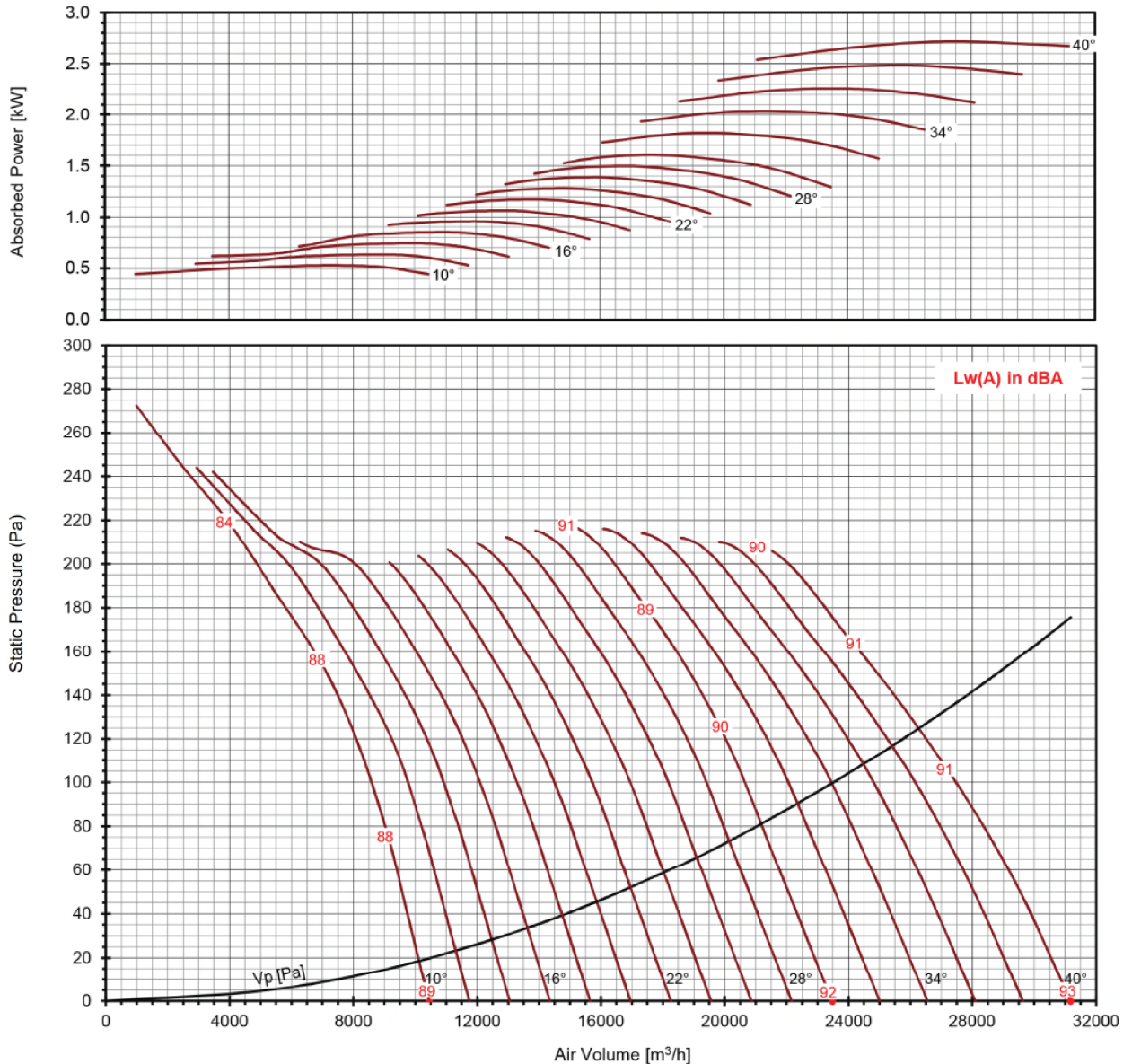

Peak Absorbed Power (kW)

N (rpm)	Blade Pitch Angle															Lp(A) at 3m	
	10°	12°	14°	16°	18°	20°	22°	24°	26°	28°	30°	32°	34°	36°	38°		40°
960	0.53	0.63	0.74	0.85	0.96	1.06	1.17	1.28	1.39	1.50	1.61	1.82	2.03	2.25	2.49	2.72	-20
motor	0.55	0.75		1.1		1.5		2.2		3							

* Performance certified is for installation type D - Ducted Inlet, Ducted Outlet. Performance ratings do not include the effects of appurtenances (accessories).

* The A-weighted sound ratings shown have been calculated per AMCA International Standard 301. Values shown are for inlet LwA sound power levels for installation type D: ducted inlet ducted outlet. Ratings include the effects of duct end correction.

* Lp(A) - dBA Levels are not licensed by AMCA International.



SERIES TFA 800/250/14/V

Impeller Code : 800/250
 Size : 800mm
 Outlet Area : 0.503m²

Adjustable Pitch Angle Vane Axial Fan

FEG75

50Hz
 720 rpm

$\rho = 1.2\text{kg/m}^3$

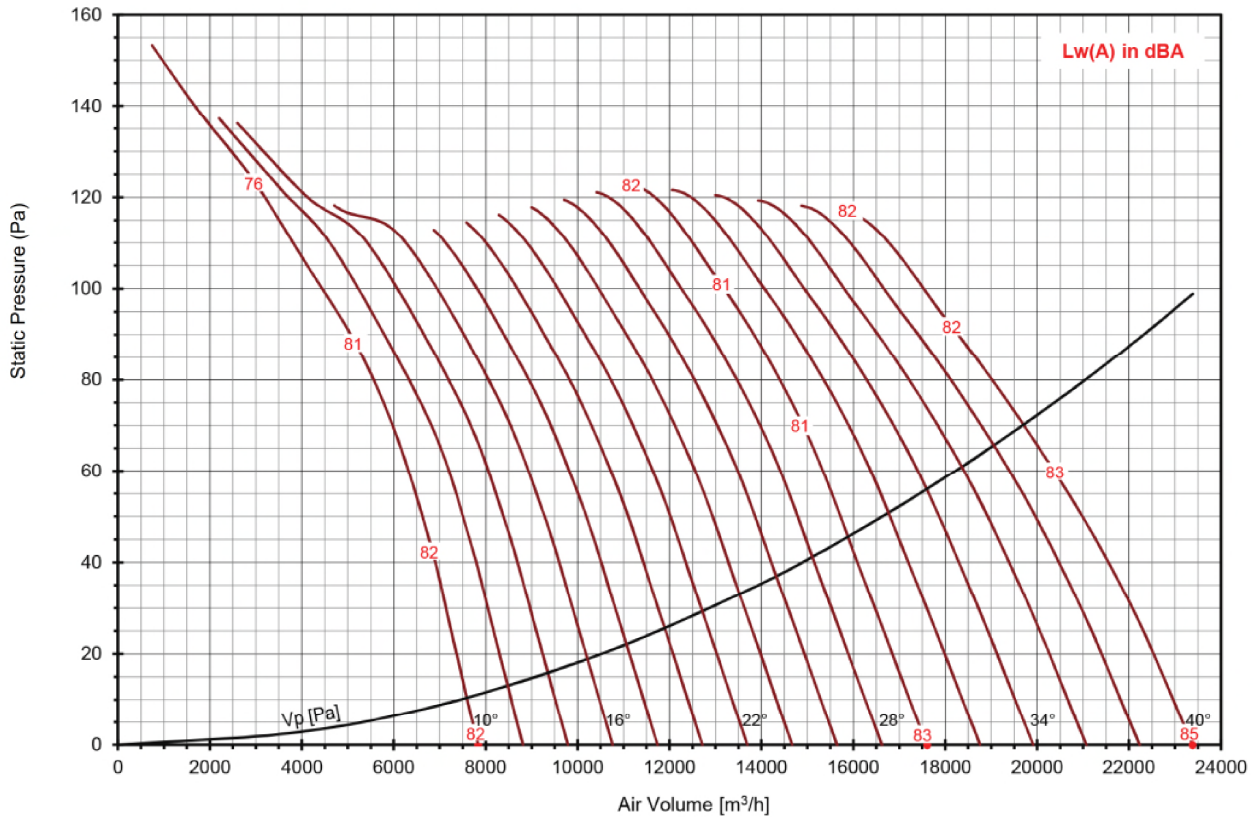
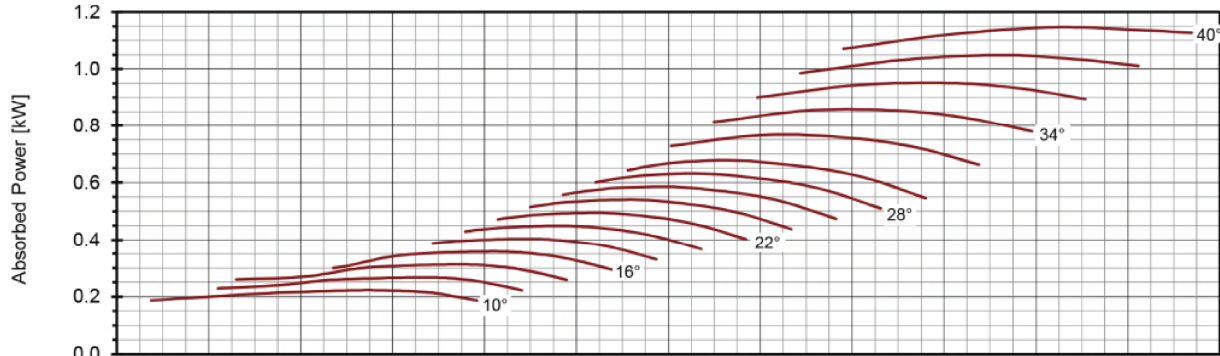

Peak Absorbed Power (kW)

N (rpm)	Blade Pitch Angle															Lp(A) at 3m	
	10°	12°	14°	16°	18°	20°	22°	24°	26°	28°	30°	32°	34°	36°	38°		40°
720 motor	0.22	0.27	0.31	0.36	0.40	0.45	0.49	0.54	0.59	0.63	0.68	0.77	0.85	0.95	1.05	1.15	-20
		0.37					0.55			0.75				1.1		1.5	

* Performance certified is for installation type D - Ducted Inlet, Ducted Outlet. Performance ratings do not include the effects of appurtenances (accessories).

* The A-weighted sound ratings shown have been calculated per AMCA International Standard 301. Values shown are for inlet Lw(A) sound power levels for installation type D: ducted inlet ducted outlet. Ratings include the effects of duct end correction.

* Lp(A) - dBA Levels are not licensed by AMCA International.



SERIES TFA 800/350/12/V

Impeller Code : 800/350
 Size : 800 mm
 Outlet area : 0.503 m²

Adjustable Pitch Angle Vane Axial Fan

FEG 63

50Hz

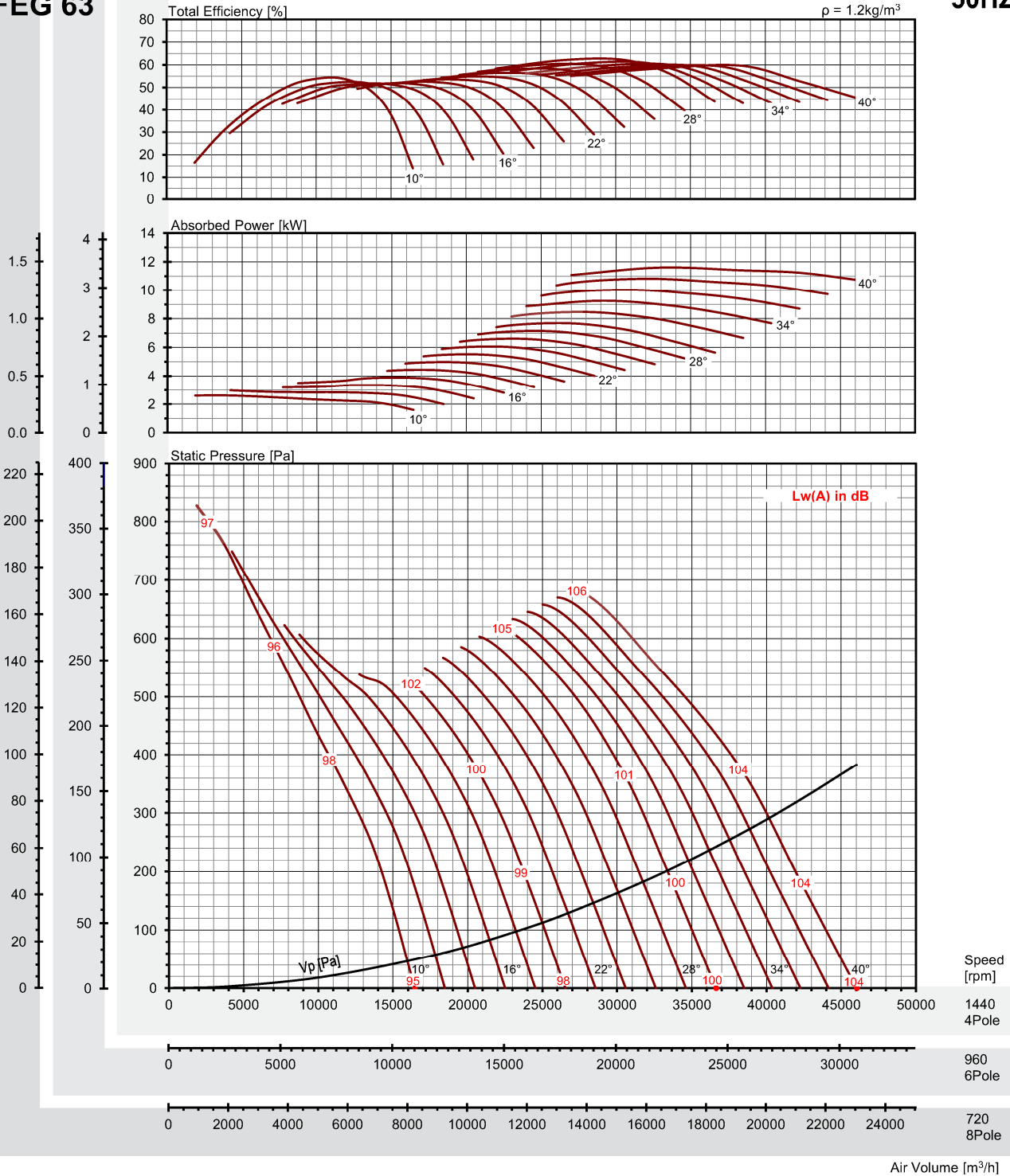

Peak Absorbed Power (kW)

N (rpm)	Blade Pitch Angle																Lw(A) in dB	Lp(A) at 3m
	10°	12°	14°	16°	18°	20°	22°	24°	26°	28°	30°	32°	34°	36°	38°	40°		
720 motor	0.33	0.37	0.42	0.49	0.55	0.62	0.69	0.76	0.83	0.89	0.96	1.06	1.16	1.25	1.35	1.45	-18	-38
960 motor	0.78	0.88	0.99	1.15	1.31	1.47	1.63	1.80	1.96	2.12	2.28	2.51	2.74	2.97	3.21	3.44	-9	-29
1440 motor	2.62	2.98	3.35	3.89	4.43	4.98	5.52	6.06	6.61	7.15	7.69	8.47	9.25	10.04	10.82	11.60	0	-20

* Performance certified is for installation type D - Ducted inlet, Ducted outlet. Performance ratings do not include the effects of aperturancs (accessories).

* The A-weighted sound ratings shown have been calculated per AMCA International Standard 301. Values shown are for inlet Lw(A) sound power levels for installation type D: ducted inlet, ducted outlet. Ratings include the effects of duct end correction.

* Lp(A) - dBA levels are not licensed by AMCA International



SERIES TFA 1000/300/10/V

Impeller Code : 1000/300
 Size : 1000mm
 Outlet Area : 0.785m²

Adjustable Pitch Angle Vane Axial Fan

FEG 67

50Hz

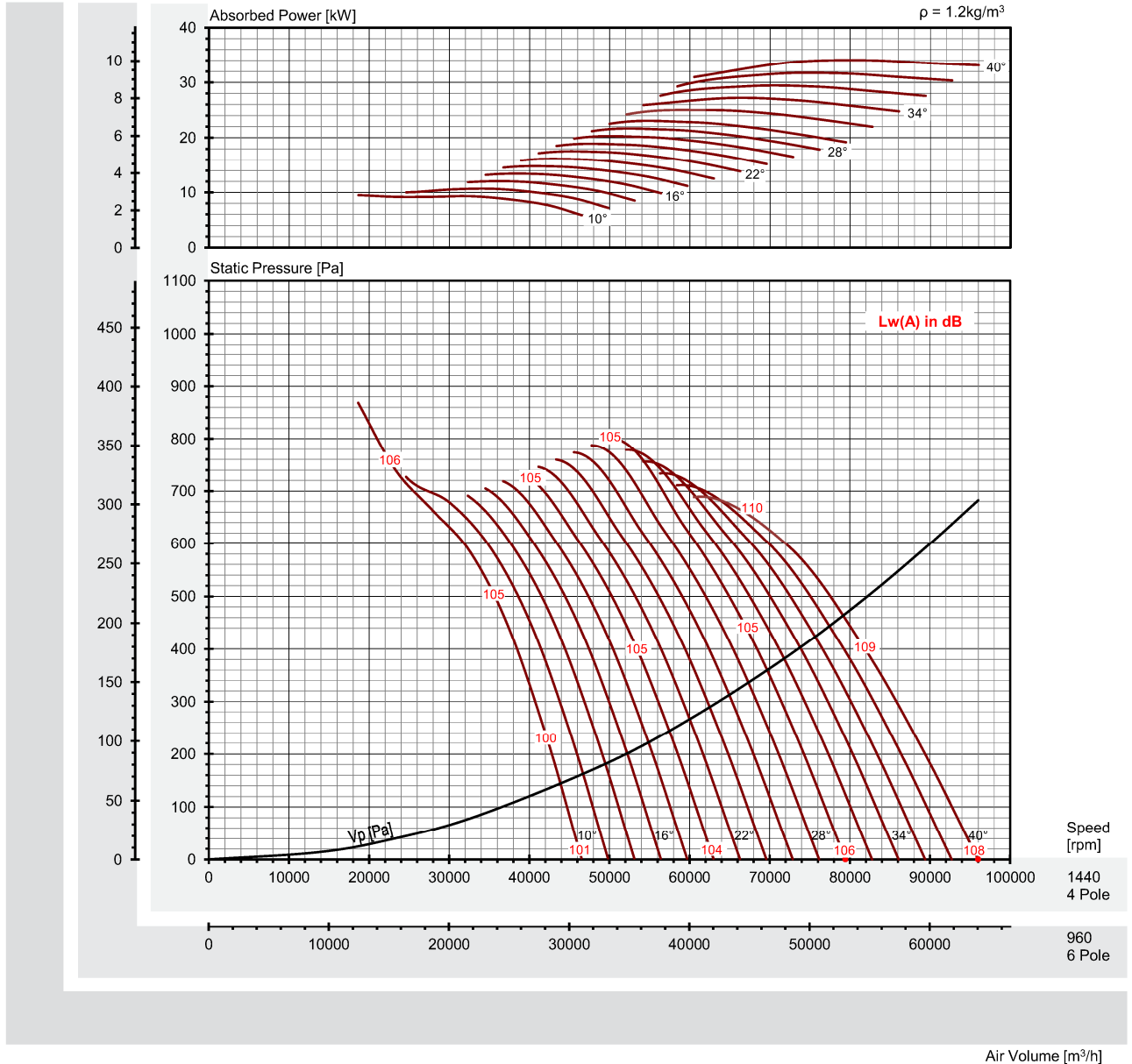

Peak Absorbed Power (kW)

N (rpm)	Blade Pitch Angle																Lw(A) in dBA	Lp(A) at 3m
	10°	12°	14°	16°	18°	20°	22°	24°	26°	28°	30°	32°	34°	36°	38°	40°		
960 motor	2.82	3.16	3.56	3.96	4.36	4.76	5.17	5.57	5.97	6.37	6.77	7.14	8.04	8.68	9.38	10.09	-9	-29
1440 motor	9.51	10.67	12.02	13.37	14.73	16.08	17.43	18.79	20.14	21.49	22.85	25.00	27.15	29.30	31.64	34.05	0	-20

* Performance certified is for installation type D - Ducted inlet, Ducted outlet. Performance ratings do not include the effects of appurtenances (accessories).

* The A-weighted sound ratings shown have been calculated per AMCA International Standard 301. Values shown are for inlet Lw(A) sound power levels for installation type D: ducted inlet, ducted outlet. Ratings include the effects of duct end correction.

* Lp(A) - dBA levels are not licensed by AMCA International



SERIES TFA 1000/350/12/V

Impeller Code : 1000/350
 Size : 1000mm
 Outlet Area : 0.786m²

Adjustable Pitch Angle Vane Axial Fan

FEG75

50Hz
1440 rpm

$\rho = 1.2\text{kg/m}^3$

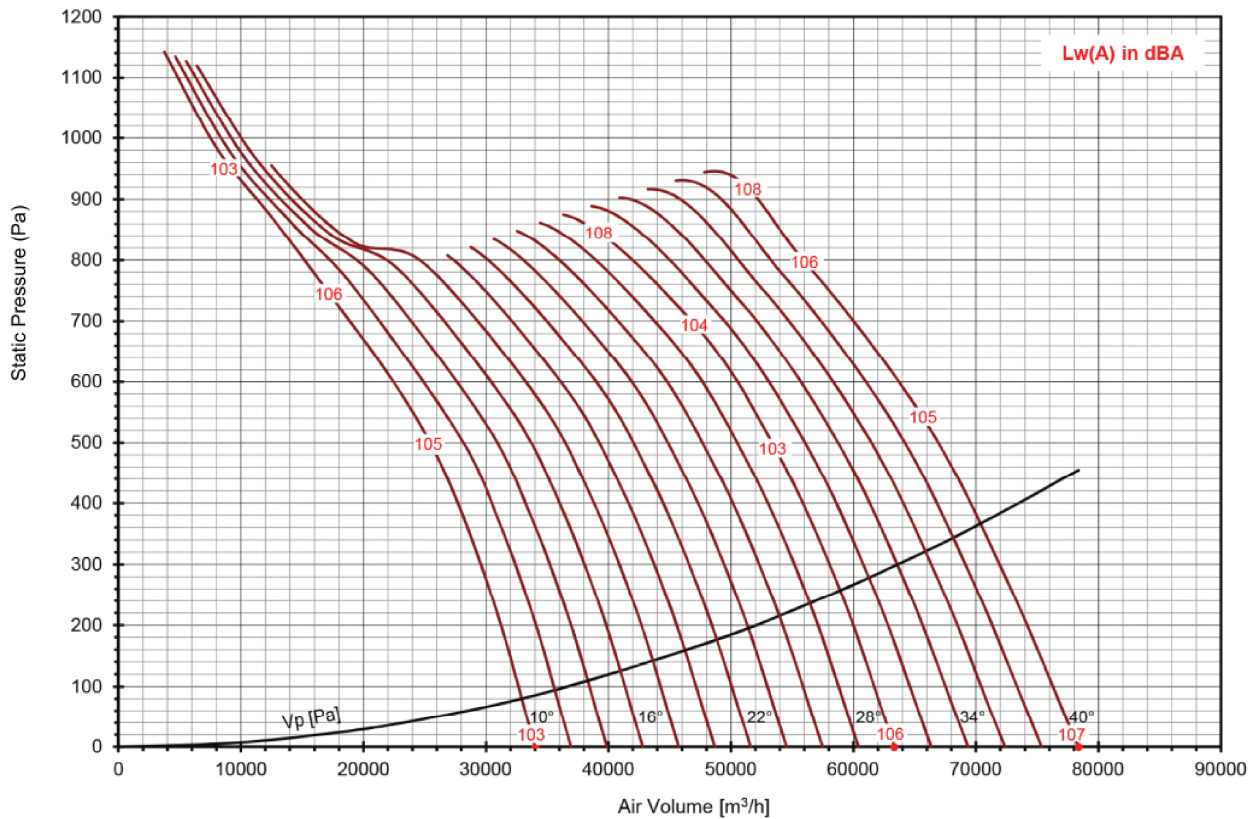
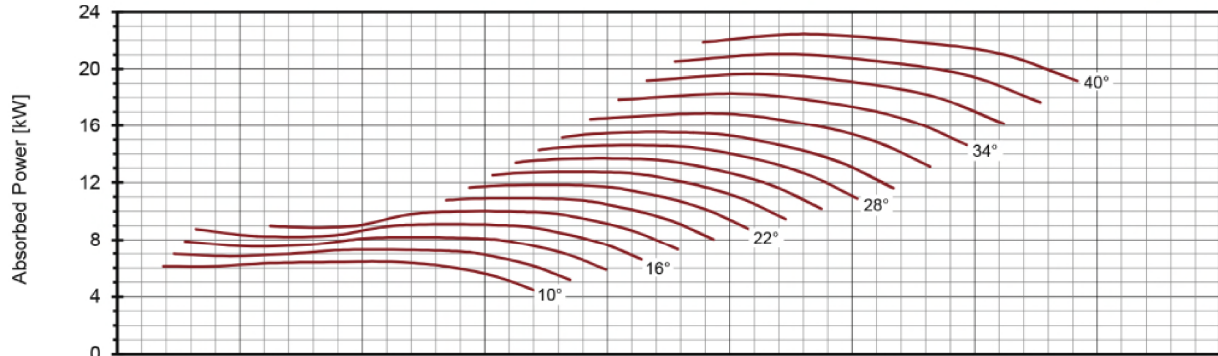

Peak Absorbed Power (kW)

N (rpm)	Blade Pitch Angle														Lp(A) at 3m		
	10°	12°	14°	16°	18°	20°	22°	24°	26°	28°	30°	32°	34°	36°		38°	40°
1440	6.45	7.28	8.15	9.03	9.94	10.9	11.8	12.7	13.6	14.6	15.5	16.9	18.3	19.7	21.1	22.4	-20
motor	7.5		11				15				18.5		22				

* Performance certified is for installation type D - Ducted Inlet, Ducted Outlet. Performance ratings do not include the effects of appurtenances (accessories).

* The A-weighted sound ratings shown have been calculated per AMCA International Standard 301. Values shown are for inlet Lw(A) sound power levels for installation type D: ducted inlet ducted outlet. Ratings include the effects of duct end correction.

* Lp(A) - dBA Levels are not licensed by AMCA International.



SERIES TFA 1000/350/12/V

Impeller Code : 1000/350
 Size : 1000mm
 Outlet Area : 0.786m²

Adjustable Pitch Angle Vane Axial Fan

FEG75

50Hz
 960 rpm

$\rho = 1.2\text{kg/m}^3$

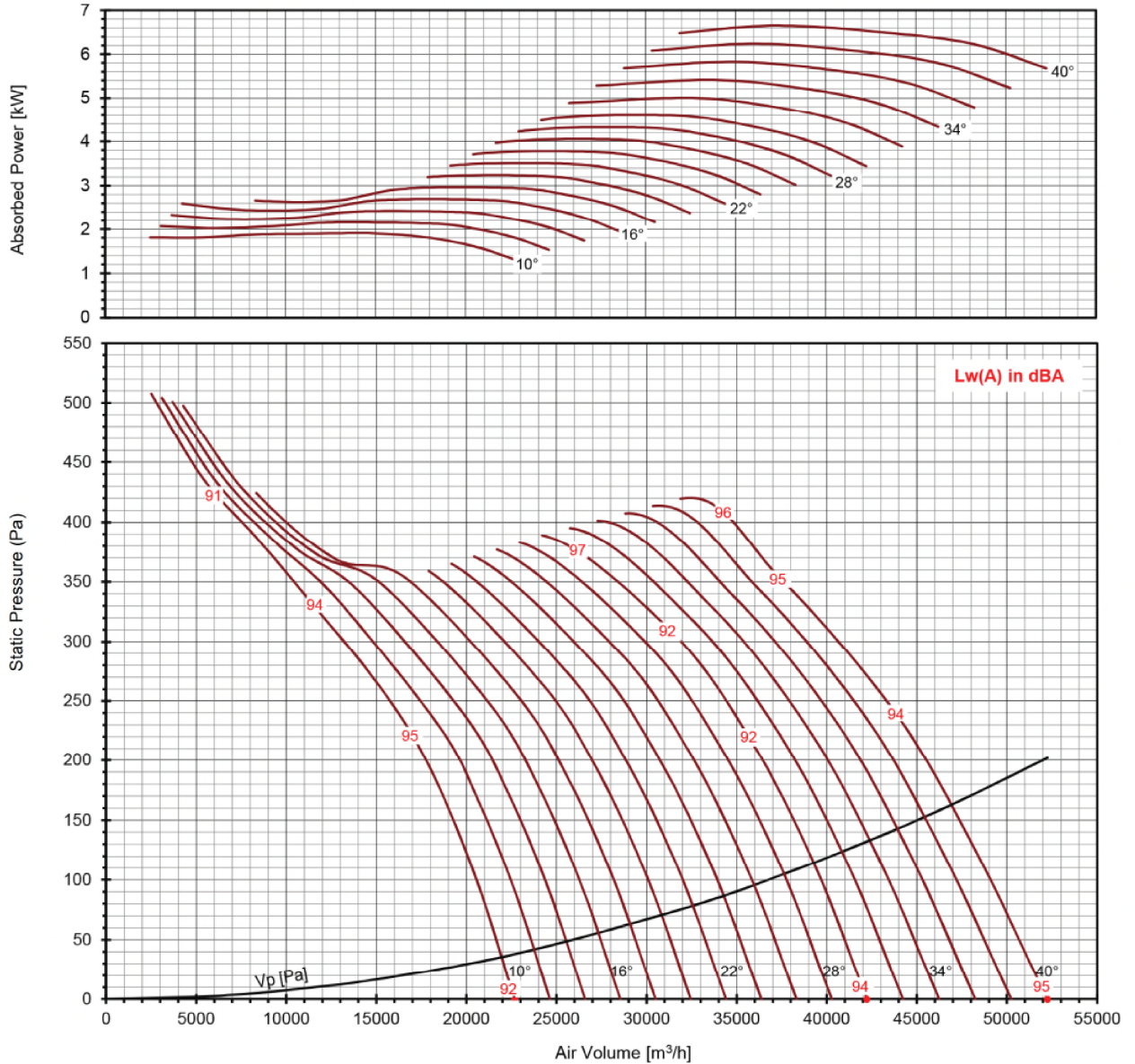

Peak Absorbed Power (kW)

N (rpm)	Blade Pitch Angle														Lp(A) at 3m		
	10°	12°	14°	16°	18°	20°	22°	24°	26°	28°	30°	32°	34°	36°		38°	40°
960 motor	1.91	2.16	2.42	2.67	2.94	3.22	3.49	3.77	4.04	4.31	4.59	5.00	5.41	5.83	6.24	6.65	-20

* Performance certified is for installation type D - Ducted Inlet, Ducted Outlet. Performance ratings do not include the effects of appurtenances (accessories).

* The A-weighted sound ratings shown have been calculated per AMCA International Standard 301. Values shown are for inlet LwA sound power levels for installation type D: ducted inlet ducted outlet. Ratings include the effects of duct end correction.

* Lp(A) - dBA Levels are not licensed by AMCA International.



SERIES TFA 1000/350/12/V

Impeller Code : 1000/350
 Size : 1000mm
 Outlet Area : 0.786m²

Adjustable Pitch Angle Vane Axial Fan

FEG75

50Hz
720 rpm

$\rho = 1.2\text{kg/m}^3$

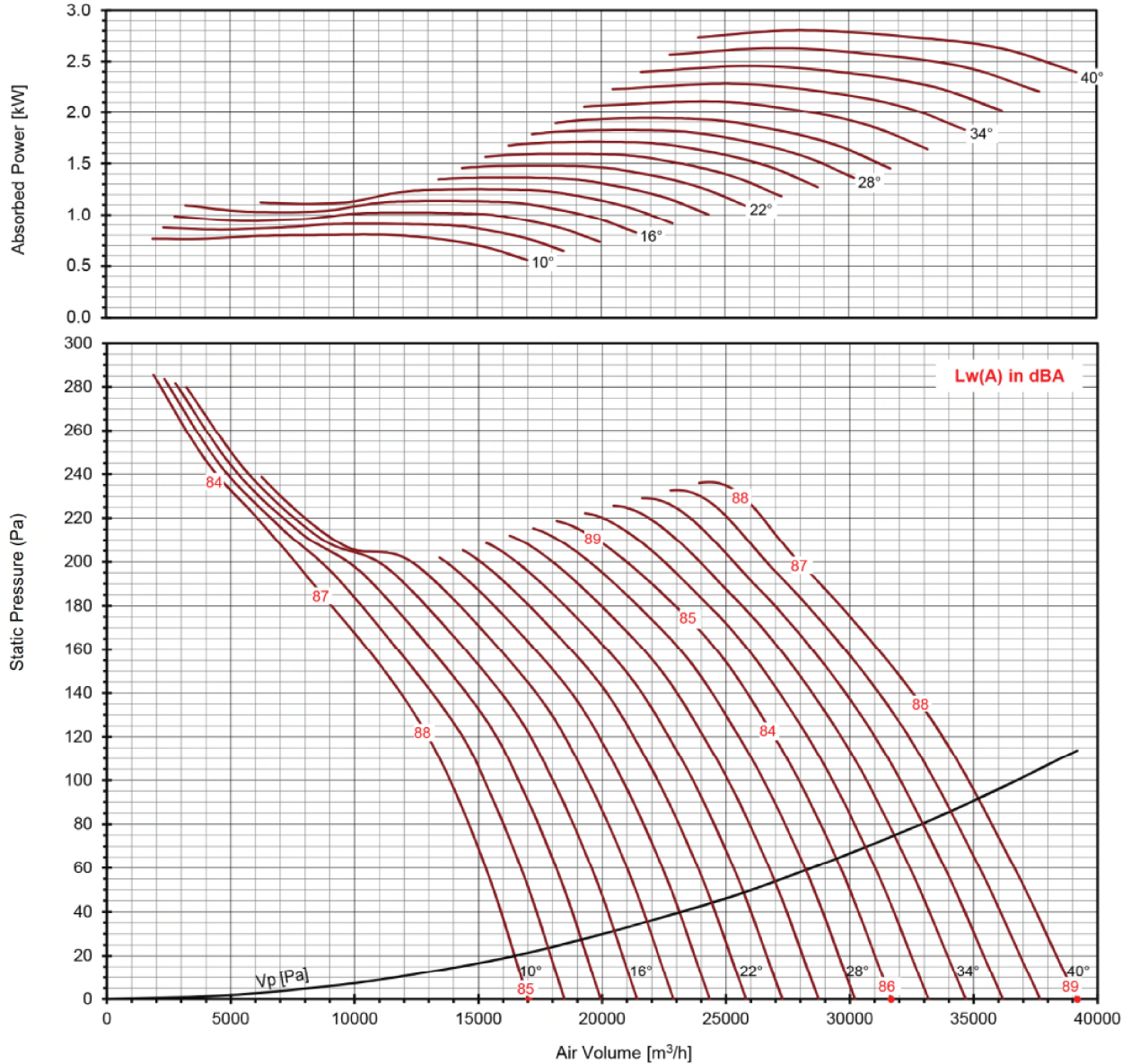

Peak Absorbed Power (kW)

N (rpm)	Blade Pitch Angle																Lp(A) at 3m
	10°	12°	14°	16°	18°	20°	22°	24°	26°	28°	30°	32°	34°	36°	38°	40°	
720	0.81	0.91	1.02	1.13	1.24	1.36	1.47	1.59	1.70	1.82	1.94	2.11	2.28	2.46	2.63	2.81	20
motor	1.1		1.5			2.2			3								

* Performance certified is for installation type D - Ducted Inlet, Ducted Outlet. Performance ratings do not include the effects of appurtenances (accessories).

* The A-weighted sound ratings shown have been calculated per AMCA International Standard 301. Values shown are for inlet Lw(A) sound power levels for installation type D: ducted inlet ducted outlet. Ratings include the effects of duct end correction.

* Lp(A) - dBA Levels are not licensed by AMCA International.



Adjustable Pitch Angle Vane Axial Fan
FEG 71

SERIES TFA 1120/300/10/V

Impeller Code : 1120/300
Size : 1120 mm
Outlet area : 0.994m²

50Hz

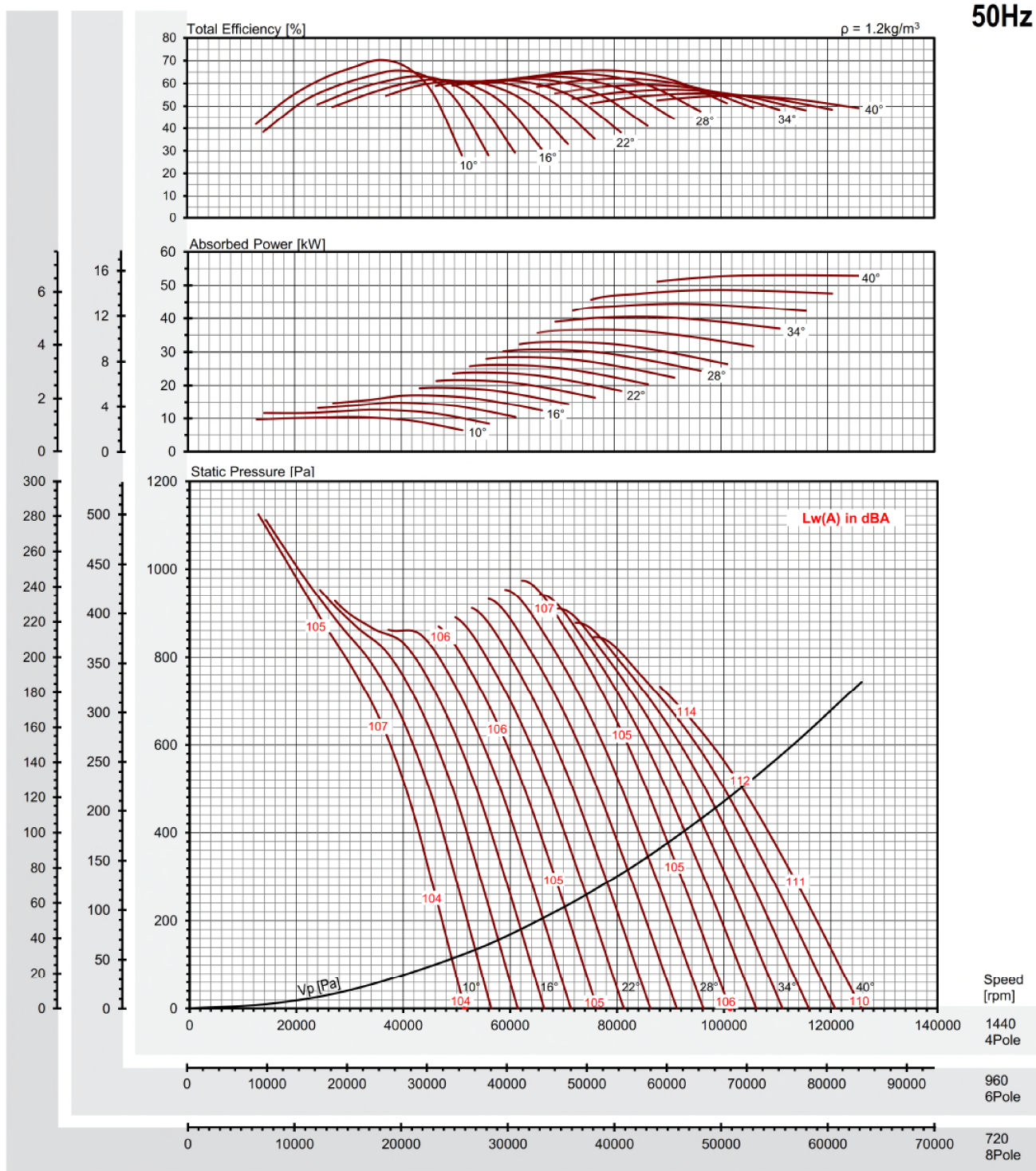

Peak Absorbed Power (kW)

N (rpm)	Blade Pitch Angle																Lw(A) in dBA	Lp(A) at 3m
	10°	12°	14°	16°	18°	20°	22°	24°	26°	28°	30°	32°	34°	36°	38°	40°		
720 motor	1.30 1.5	1.57 2.2	1.85 2.2	2.12 2.2	2.41 2.69	2.69 3	2.98 3	3.27 3.55	3.55 4	3.84 4	4.13 4.58	4.58 5.5	5.05 5.5	5.56 6.08	6.08 7.5	6.63 7.5	-17	-37
960 motor	3.08 4	3.73 4	4.38 5.5	5.03 5.5	5.70 7.5	6.38 7.5	7.06 7.5	7.74 11	8.42 11	9.10 11	9.78 11	10.85 15	11.97 15	13.19 15	14.41 18.5	15.72 18.5	-9	-29
1440 motor	10.41 11	12.60 15	14.79 15	16.98 18.5	19.25 22	21.54 22	23.83 22	26.13 30	28.42 30	30.71 37	33.01 37	36.63 45	40.39 45	44.51 55	48.63 55	53.05 55	0	-20

Air Volume [m³/h]



* Performance certified is for installation type D - Ducted inlet, Ducted outlet. Performance ratings do not include the effects of appurtenances (accessories).

* The A-weighted sound ratings shown have been calculated per AMCA International Standard 301. Values shown are for inlet Lw(A) sound power levels for installation type D: ducted inlet, ducted outlet. Ratings include the effects of duct end correction.

* Lp(A) - dBA levels are not licensed by AMCA International

50Hz

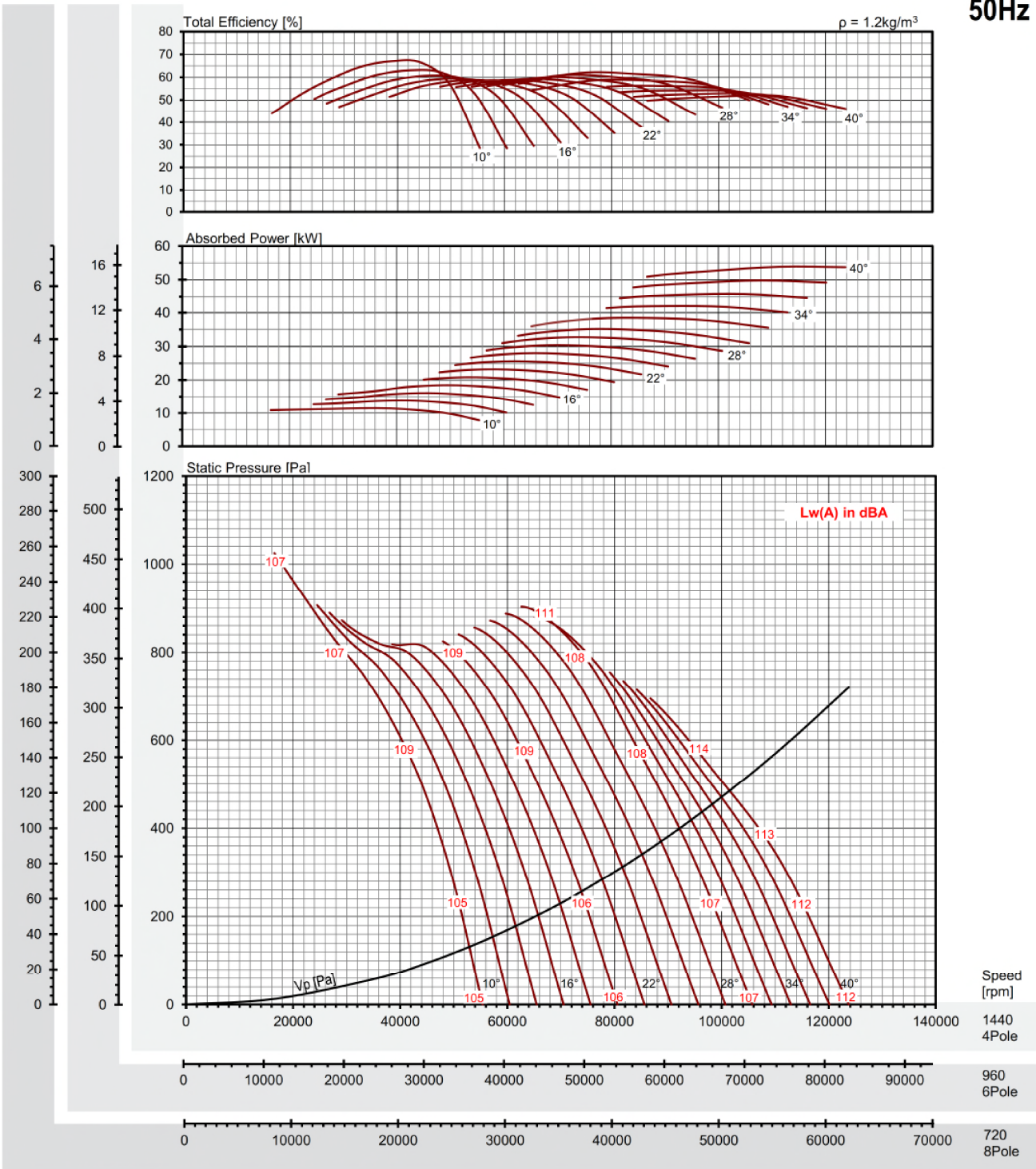

Peak Absorbed Power (kW)

Air Volume [m³/h]

N (rpm)	Blade Pitch Angle																Lw(A) in dBA	Lp(A) at 3m
	10°	12°	14°	16°	18°	20°	22°	24°	26°	28°	30°	32°	34°	36°	38°	40°		
720 motor	1.43	1.72	2.01	2.31	2.60	2.90	3.19	3.49	3.79	4.08	4.38	4.80	5.25	5.72	6.22	6.73	-17	-37
960 motor	3.38	4.07	4.77	5.47	6.17	6.87	7.57	8.27	8.97	9.67	10.37	11.39	12.44	13.56	14.75	15.95	-10	-30
1440 motor	11.41	13.73	16.09	18.46	20.82	23.19	25.56	27.92	30.29	32.65	35.02	38.43	41.98	45.75	49.80	53.85	0	-20

* Performance certified is for installation type D - Ducted inlet, Ducted outlet. Performance ratings do not include the effects of appurtenances (accessories).

* The A-weighted sound ratings shown have been calculated per AMCA International Standard 301. Values shown are for inlet Lw(A) sound power levels for installation type D: ducted inlet, ducted outlet. Ratings include the effects of duct end correction.

* Lp(A) - dBA levels are not licensed by AMCA International



SERIES TFA 1250/350/12/V

Adjustable Pitch Angle Vane Axial Fan

Impeller Code : 1250/350
 Size : 1250mm
 Outlet Area : 1.227m²

FEG71

50Hz
1440 rpm

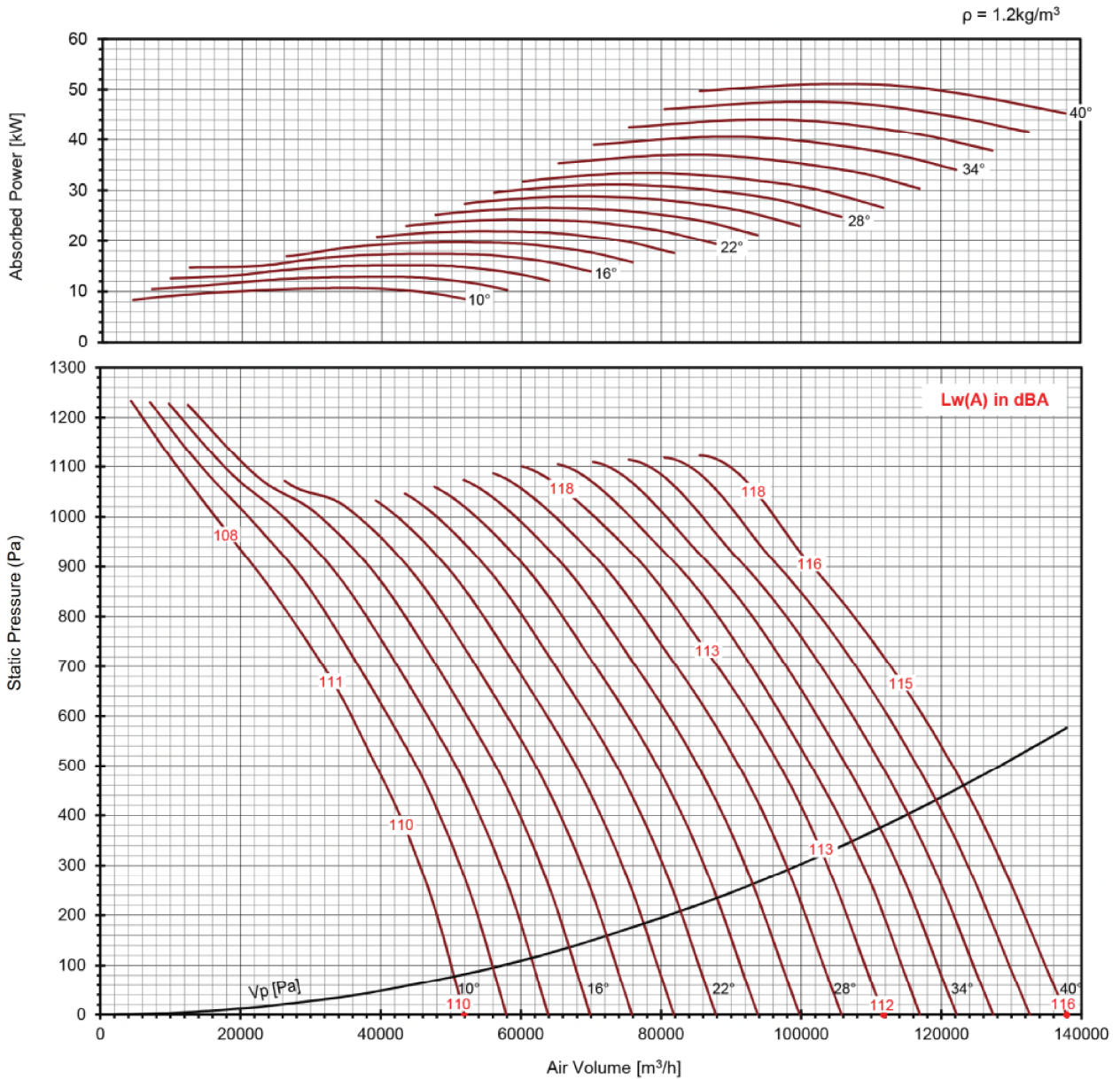

Peak Absorbed Power (kW)

N (rpm)	Blade Pitch Angle														Lp(A) at 3m		
	10°	12°	14°	16°	18°	20°	22°	24°	26°	28°	30°	32°	34°	36°		38°	40°
1440	10.7	12.8	15.1	17.3	19.6	21.9	24.2	26.5	28.8	31.1	33.4	36.9	40.4	44.0	47.5	51.1	-20
motor	11	15	18.5	22			30			37		45	55				

* Performance certified is for installation type D - Ducted Inlet, Ducted Outlet. Performance ratings do not include the effects of appurtenances (accessories).

* The A-weighted sound ratings shown have been calculated per AMCA International Standard 301. Values shown are for inlet Lw(A) sound power levels for installation type D: ducted inlet ducted outlet. Ratings include the effects of duct end correction.

* Lp(A) - dBA Levels are not licensed by AMCA International.



SERIES TFA 1250/350/12/V

Impeller Code : 1250/350
 Size : 1250mm
 Outlet Area : 1.227m²

Adjustable Pitch Angle Vane Axial Fan

FEG71

50Hz
 960 rpm

$\rho = 1.2\text{kg/m}^3$

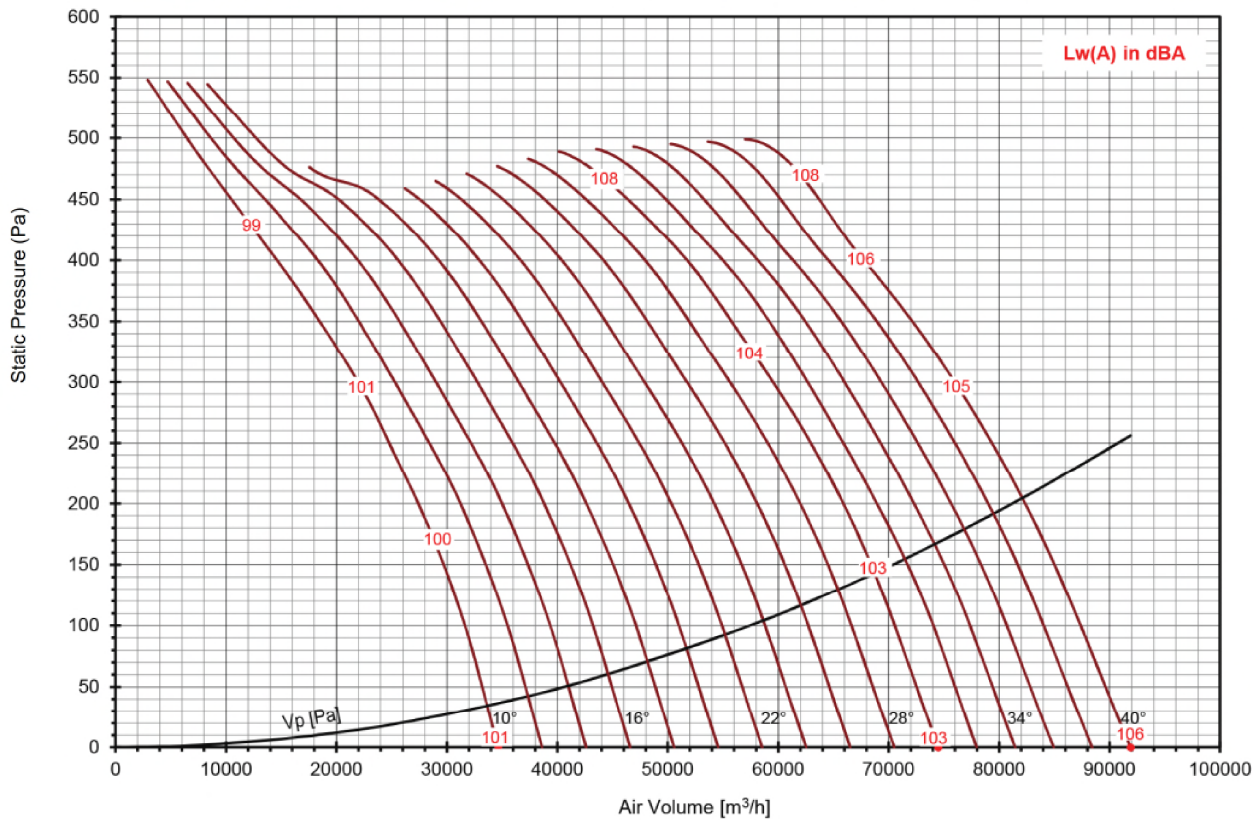
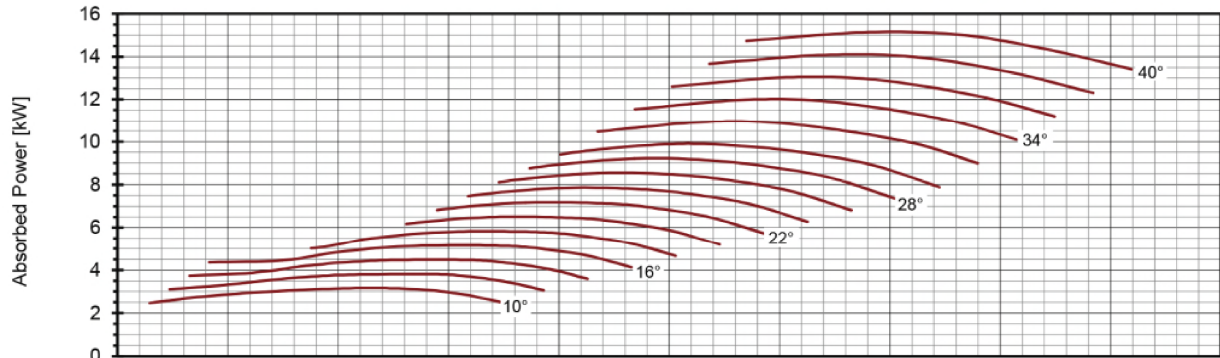

Peak Absorbed Power (kW)

N (rpm)	Blade Pitch Angle															Lp(A) at 3m	
	10°	12°	14°	16°	18°	20°	22°	24°	26°	28°	30°	32°	34°	36°	38°		40°
960	3.16	3.80	4.47	5.13	5.81	6.49	7.17	7.85	8.53	9.21	9.89	10.9	12.0	13.0	14.1	15.1	-20
motor	4		5.5		7.5		11			15							

* Performance certified is for installation type D - Ducted Inlet, Ducted Outlet. Performance ratings do not include the effects of appurtenances (accessories).

* The A-weighted sound ratings shown have been calculated per AMCA International Standard 301. Values shown are for inlet Lw(A) sound power levels for installation type D: ducted inlet ducted outlet. Ratings include the effects of duct end correction.

* Lp(A) - dBA Levels are not licensed by AMCA International.



SERIES TFA 1250/350/12/V

Impeller Code : 1250/350
 Size : 1250mm
 Outlet Area : 1.227m²

Adjustable Pitch Angle Vane Axial Fan

FEG71

50Hz
720 rpm

$\rho = 1.2\text{kg/m}^3$

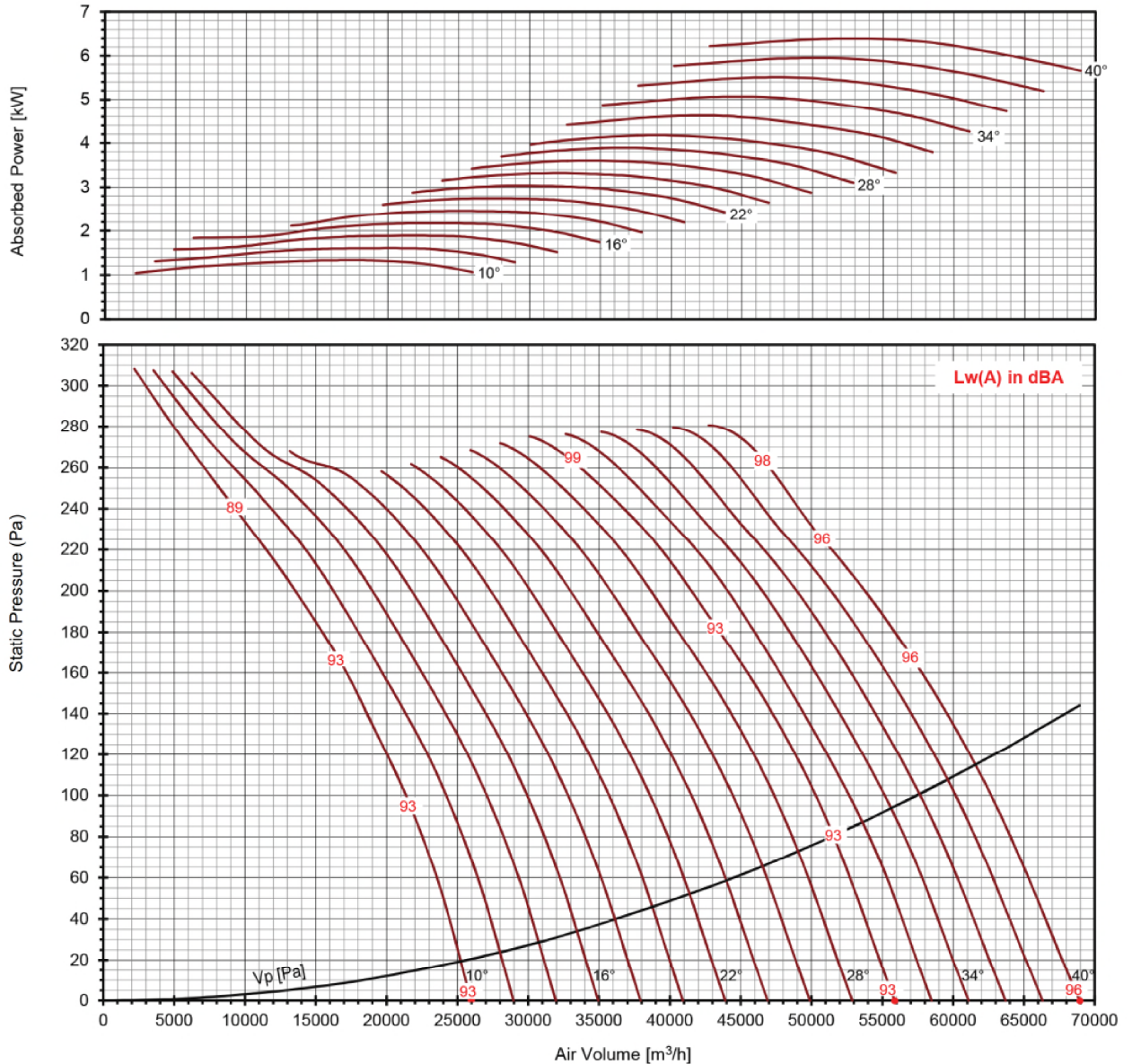

Peak Absorbed Power (kW)

N (rpm)	Blade Pitch Angle														Lp(A) at 3m		
	10°	12°	14°	16°	18°	20°	22°	24°	26°	28°	30°	32°	34°	36°		38°	40°
720	1.33	1.61	1.88	2.16	2.45	2.74	3.02	3.31	3.60	3.89	4.17	4.61	5.06	5.50	5.94	6.38	-20
motor	1.5	2.2	3	4	5.5	7.5											

* Performance certified is for installation type D - Ducted Inlet, Ducted Outlet. Performance ratings do not include the effects of appurtenances (accessories).

* The A-weighted sound ratings shown have been calculated per AMCA International Standard 301. Values shown are for inlet LwiA sound power levels for installation type D: ducted inlet ducted outlet. Ratings include the effects of duct end correction.

* Lp(A) - dBA Levels are not licensed by AMCA International.



SERIES TFA 1400/350/12/V

Impeller Code : 1400/350
 Size : 1400mm
 Outlet Area : 1.540m²

Adjustable Pitch Angle Vane Axial Fan

FEG75

50Hz
1440 rpm

$\rho = 1.2\text{kg/m}^3$

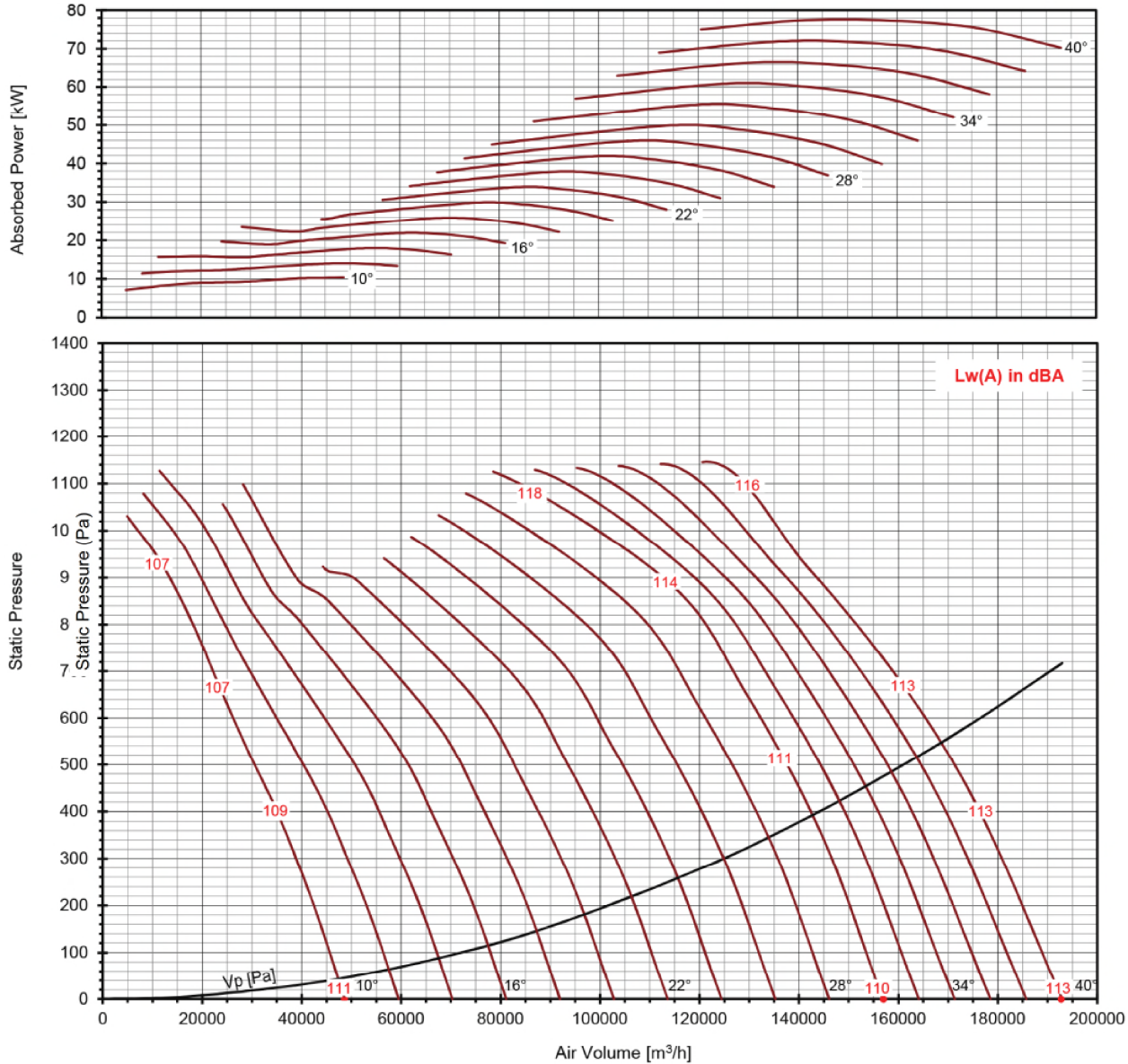

Peak Absorbed Power (kW)

N (rpm)	Blade Pitch Angle														Lp(A) at 3m		
	10°	12°	14°	16°	18°	20°	22°	24°	26°	28°	30°	32°	34°	36°		38°	40°
1440	10.4	14.0	17.9	21.8	25.8	29.8	33.8	37.8	41.8	45.8	49.8	55.3	60.9	66.4	71.9	77.4	-20
motor	11	15	18.5	22	30	37	45	55	75	90							

* Performance certified is for installation type B - Free Inlet, Ducted Outlet. Performance ratings do not include the effects of appurtenances (accessories).

* The A-weighted sound ratings shown have been calculated per AMCA International Standard 301. Values shown are for outlet LwOa sound power levels for installation type B: free inlet ducted outlet. Ratings include the effects of duct end correction.

* Lp(A) - dBA Levels are not licensed by AMCA International.



SERIES TFA 1400/350/12/V

Impeller Code : 1400/350
 Size : 1400mm
 Outlet Area : 1.540m²

Adjustable Pitch Angle Vane Axial Fan

FEG75

50Hz
960 rpm

$\rho = 1.2\text{kg/m}^3$

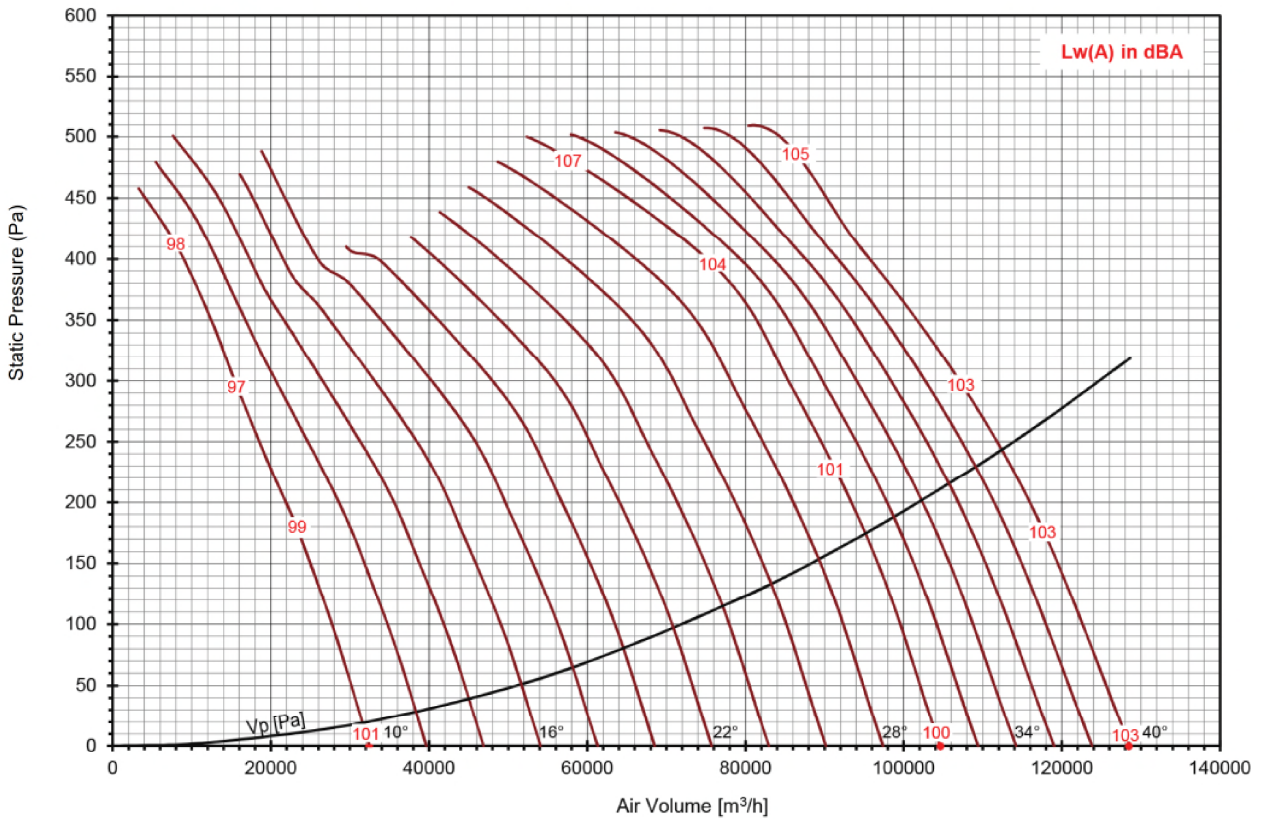
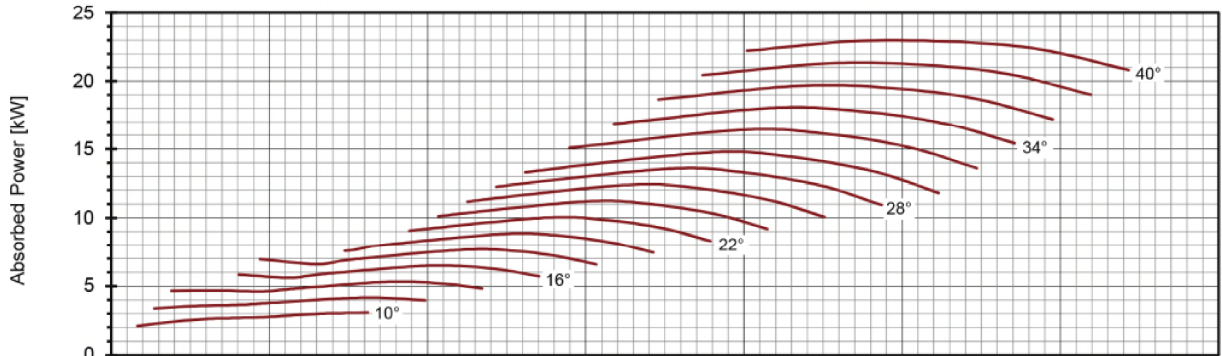

Peak Absorbed Power (kW)

N (rpm)	Blade Pitch Angle														Lp(A) at 3m		
	10°	12°	14°	16°	18°	20°	22°	24°	26°	28°	30°	32°	34°	36°		38°	40°
960	3.08	4.16	5.30	6.45	7.64	8.83	10.0	11.2	12.4	13.6	14.8	16.4	18.0	19.7	21.3	22.9	-20
motor	4	5.5	7.5		11			15			18.5		22		30		

* Performance certified is for installation type B - Free Inlet, Ducted Outlet. Performance ratings do not include the effects of appurtenances (accessories).

* The A-weighted sound ratings shown have been calculated per AMCA International Standard 301. Values shown are for outlet LwoA sound power levels for installation type B: free inlet ducted outlet. Ratings include the effects of duct end correction.

* Lp(A) - dBA Levels are not licensed by AMCA International.



SERIES TFA 1400/350/12/V

Impeller Code : 1400/350
 Size : 1400mm
 Outlet Area : 1.540m²

Adjustable Pitch Axial Fan - V Series

FEG75

50Hz
 720 rpm

$\rho = 1.2\text{kg/m}^3$

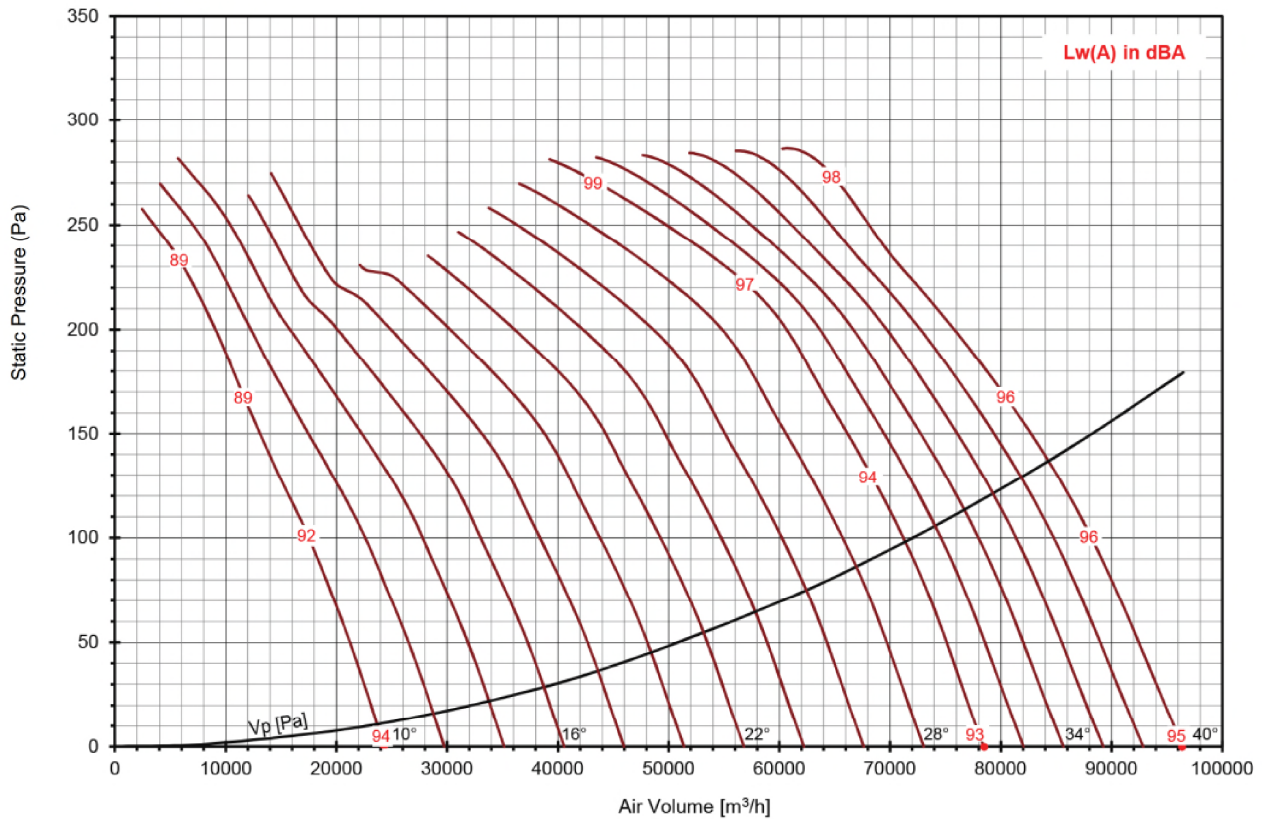
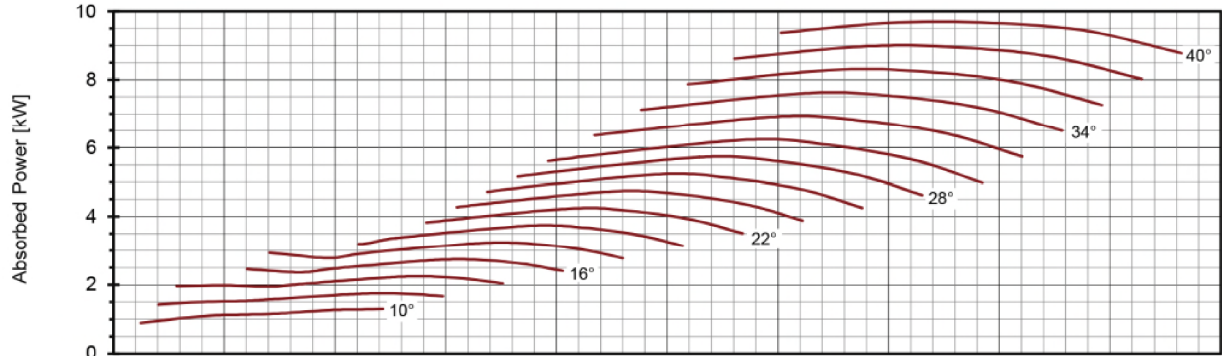

Peak Absorbed Power (kW)

N (rpm)	Blade Pitch Angle														Lp(A) at 3m		
	10°	12°	14°	16°	18°	20°	22°	24°	26°	28°	30°	32°	34°	36°		38°	40°
720	1.30	1.75	2.24	2.72	3.22	3.72	4.22	4.72	5.22	5.72	6.23	6.92	7.61	8.30	8.99	9.68	-20
motor	1.5	2.2	3	4	5.5	7.5	11										

* Performance certified is for installation type B - Free Inlet, Ducted Outlet. Performance ratings do not include the effects of appurtenances (accessories).

* The A-weighted sound ratings shown have been calculated per AMCA International Standard 301. Values shown are for outlet LwoA sound power levels for installation type B: free inlet ducted outlet. Ratings include the effects of duct end correction.

* Lp(A) - dBA Levels are not licensed by AMCA International.



SERIES TFA 1400/350/12/V

Impeller Code : 1400/350
 Size : 1400mm
 Outlet Area : 1.540m²

Adjustable Pitch Angle Vane Axial Fan

FEG75

50Hz
580 rpm

$\rho = 1.2\text{kg/m}^3$

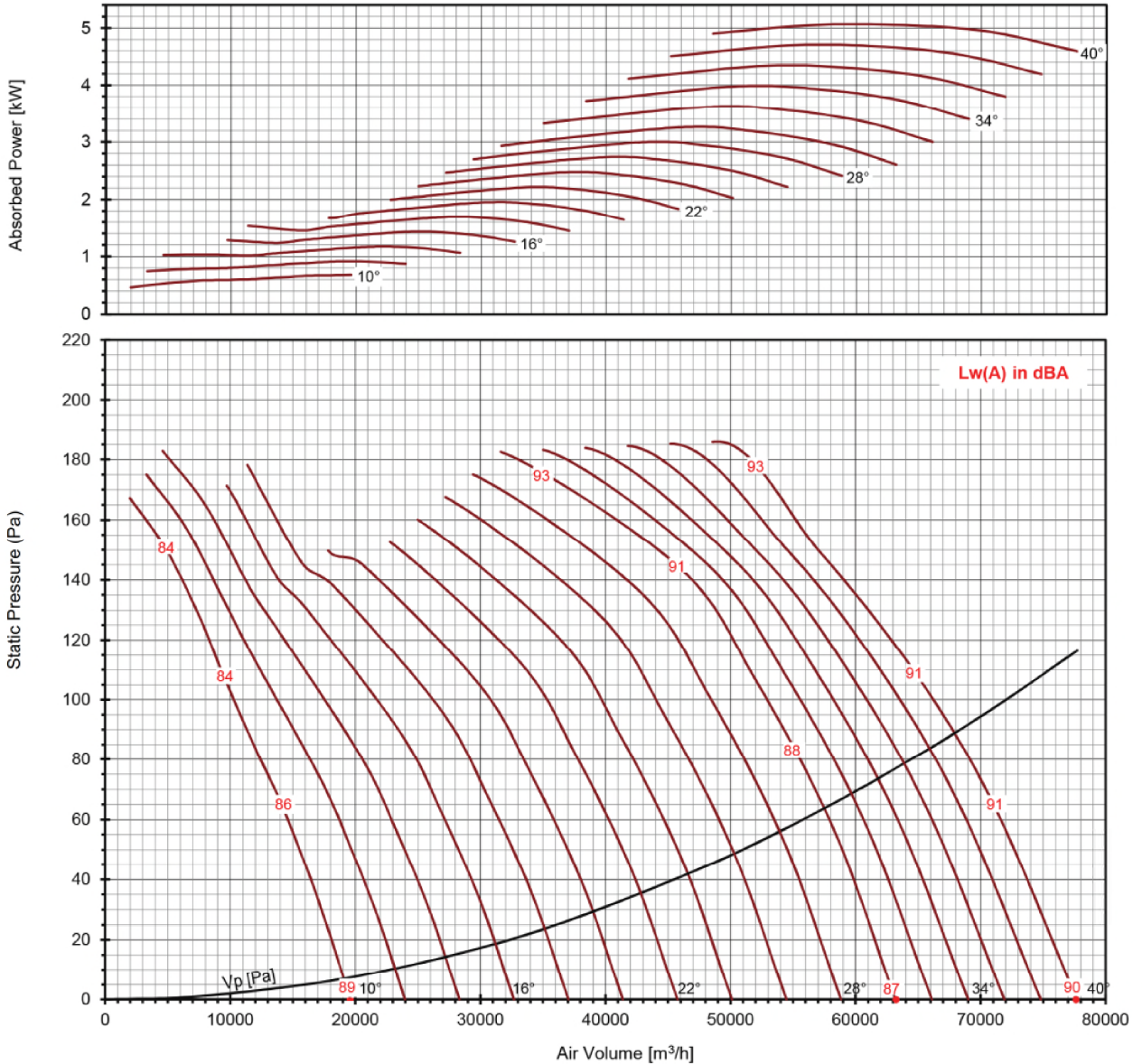

Peak Absorbed Power (kW)

N (rpm)	Blade Pitch Angle															Lp(A) at 3m	
	10°	12°	14°	16°	18°	20°	22°	24°	26°	28°	30°	32°	34°	36°	38°		40°
580	0.68	0.92	1.17	1.42	1.68	1.95	2.21	2.47	2.73	2.99	3.25	3.62	3.98	4.34	4.70	5.06	-20
motor	0.75	1.1	1.5	2.2	3			4			5.5						

* Performance certified is for installation type B - Free Inlet, Ducted Outlet. Performance ratings do not include the effects of appurtenances (accessories).

* The A-weighted sound ratings shown have been calculated per AMCA International Standard 301. Values shown are for outlet LwoA sound power levels for installation type B: free inlet ducted outlet. Ratings include the effects of duct end correction.

* Lp(A) - dBA Levels are not licensed by AMCA International.



SERIES TFA 1400/420/11/V

Impeller Code : 1400/420
 Size : 1400mm
 Outlet Area : 1.540m²

Adjustable Pitch Angle Vane Axial Fan

FEG71

50Hz
1440 rpm

$\rho = 1.2\text{kg/m}^3$

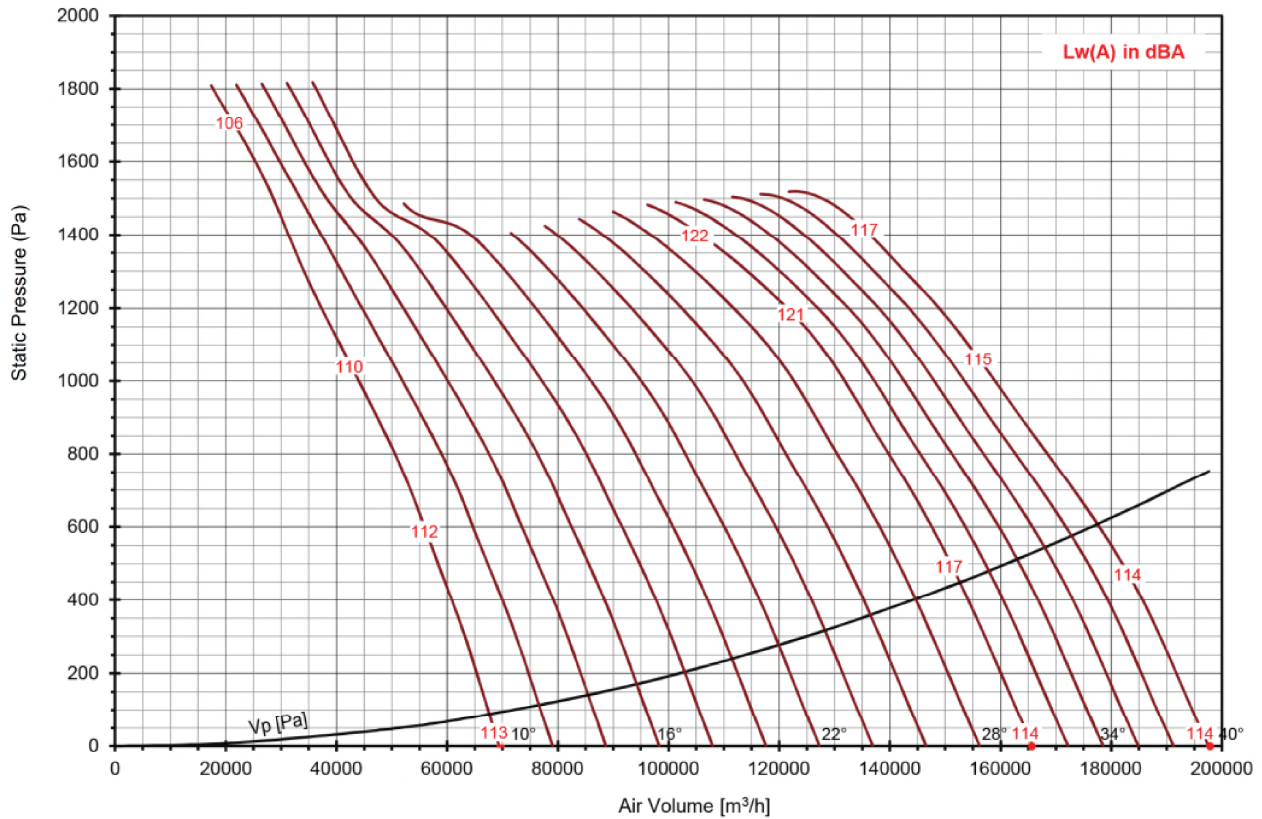
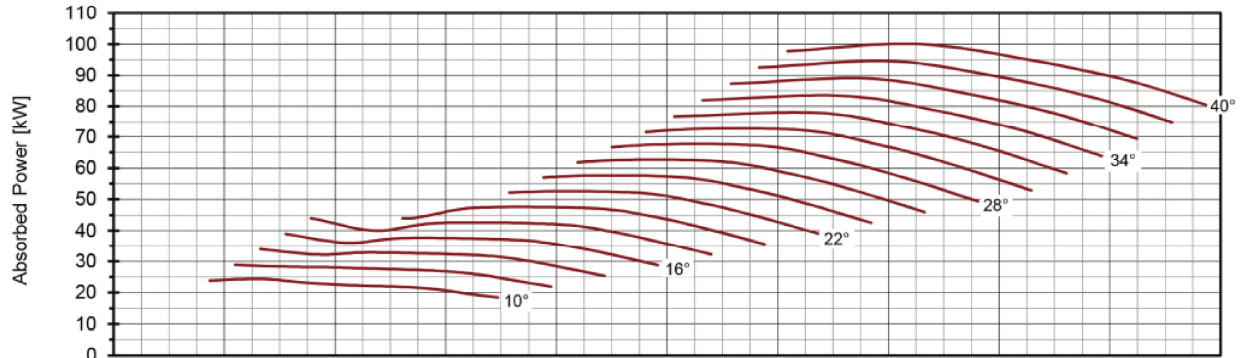

Peak Absorbed Power (kW)

N (rpm)	Blade Pitch Angle																Lp(A) at 3m
	10°	12°	14°	16°	18°	20°	22°	24°	26°	28°	30°	32°	34°	36°	38°	40°	
1440	24.3	28.9	33.9	38.9	44.0	47.3	52.1	57.2	62.2	67.3	72.3	77.9	83.4	89.0	94.5	100.1	20
motor	30		37	45		55		75			90		110				

* Performance certified is for installation type B - Free Inlet, Ducted Outlet. Performance ratings do not include the effects of appurtenances (accessories).

* The A-weighted sound ratings shown have been calculated per AMCA International Standard 301. Values shown are for outlet LwoA sound power levels for installation type B: free inlet ducted outlet. Ratings include the effects of duct end correction.

* Lp(A) - dBA Levels are not licensed by AMCA International.



SERIES TFA 1400/420/11/V

Impeller Code : 1400/420
 Size : 1400mm
 Outlet Area : 1.540m²

Adjustable Pitch Angle Vane Axial Fan

FEG71

50Hz
960 rpm

$\rho = 1.2\text{kg/m}^3$

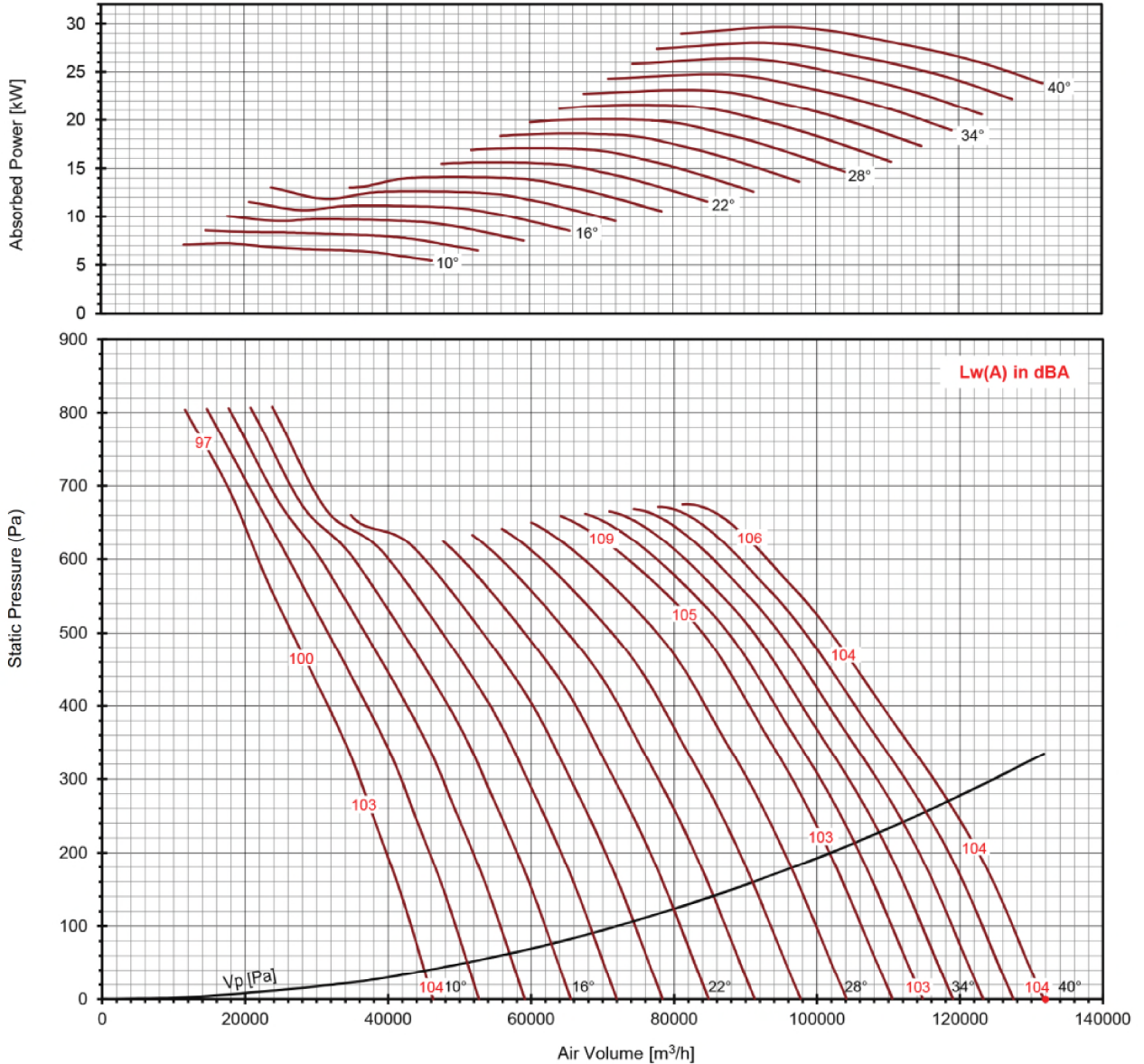

Peak Absorbed Power (kW)

N (rpm)	Blade Pitch Angle																Lp(A) at 3m
	10°	12°	14°	16°	18°	20°	22°	24°	26°	28°	30°	32°	34°	36°	38°	40°	
960	7.2	8.6	10.0	11.5	13.0	14.0	15.5	16.9	18.4	19.9	21.4	23.1	24.7	26.4	28.0	29.7	-20
motor	7.5	11		15			18.5		22			30					

* Performance certified is for installation type B - Free Inlet, Ducted Outlet. Performance ratings do not include the effects of appurtenances (accessories).

* The A-weighted sound ratings shown have been calculated per AMCA International Standard 301. Values shown are for outlet LwoA sound power levels for installation type B: free inlet ducted outlet. Ratings include the effects of duct end correction.

* Lp(A) - dBA Levels are not licensed by AMCA International.



SERIES TFA 1400/420/11/V

Impeller Code : 1400/420
 Size : 1400mm
 Outlet Area : 1.540m²

Adjustable Pitch Angle Vane Axial Fan

FEG71

50Hz
 720 rpm

$\rho = 1.2\text{kg/m}^3$

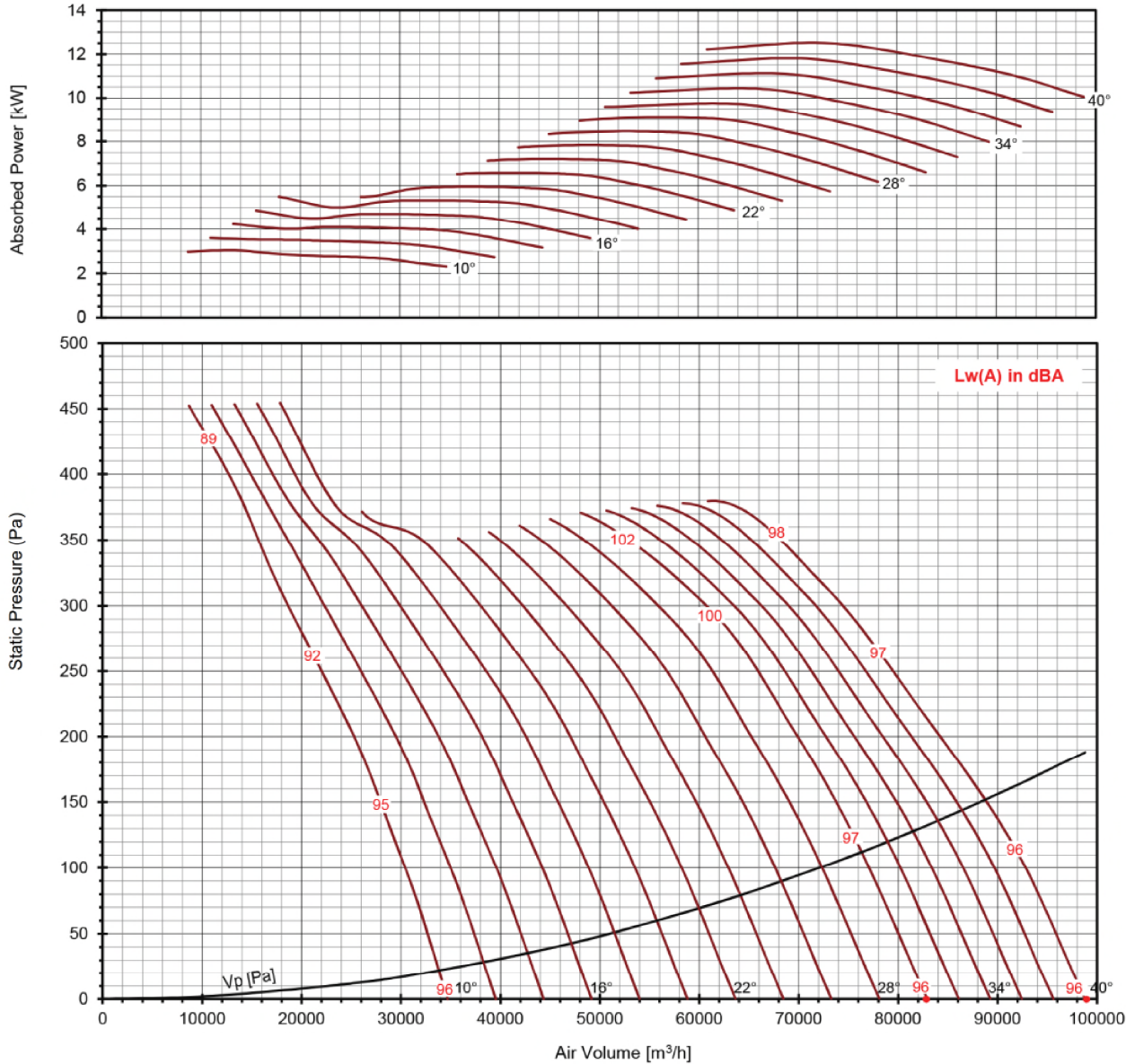

Peak Absorbed Power (kW)

N (rpm)	Blade Pitch Angle														Lp(A) at 3m		
	10°	12°	14°	16°	18°	20°	22°	24°	26°	28°	30°	32°	34°	36°		38°	40°
720 motor	3.04	3.61	4.24	4.87	5.50	5.91	6.52	7.15	7.78	8.41	9.04	9.73	10.43	11.12	11.82	12.51	-20

* Performance certified is for installation type B - Free Inlet, Ducted Outlet. Performance ratings do not include the effects of appurtenances (accessories).

* The A-weighted sound ratings shown have been calculated per AMCA International Standard 301. Values shown are for outlet LwA sound power levels for installation type B: free inlet ducted outlet. Ratings include the effects of duct end correction.

* Lp(A) - dBA Levels are not licensed by AMCA International.



SERIES TFA 1400/420/11/V

Impeller Code : 1400/420
 Size : 1400mm
 Outlet Area : 1.540m²

Adjustable Pitch Angle Vane Axial Fan

FEG71

50Hz
580 rpm

$\rho = 1.2\text{kg/m}^3$

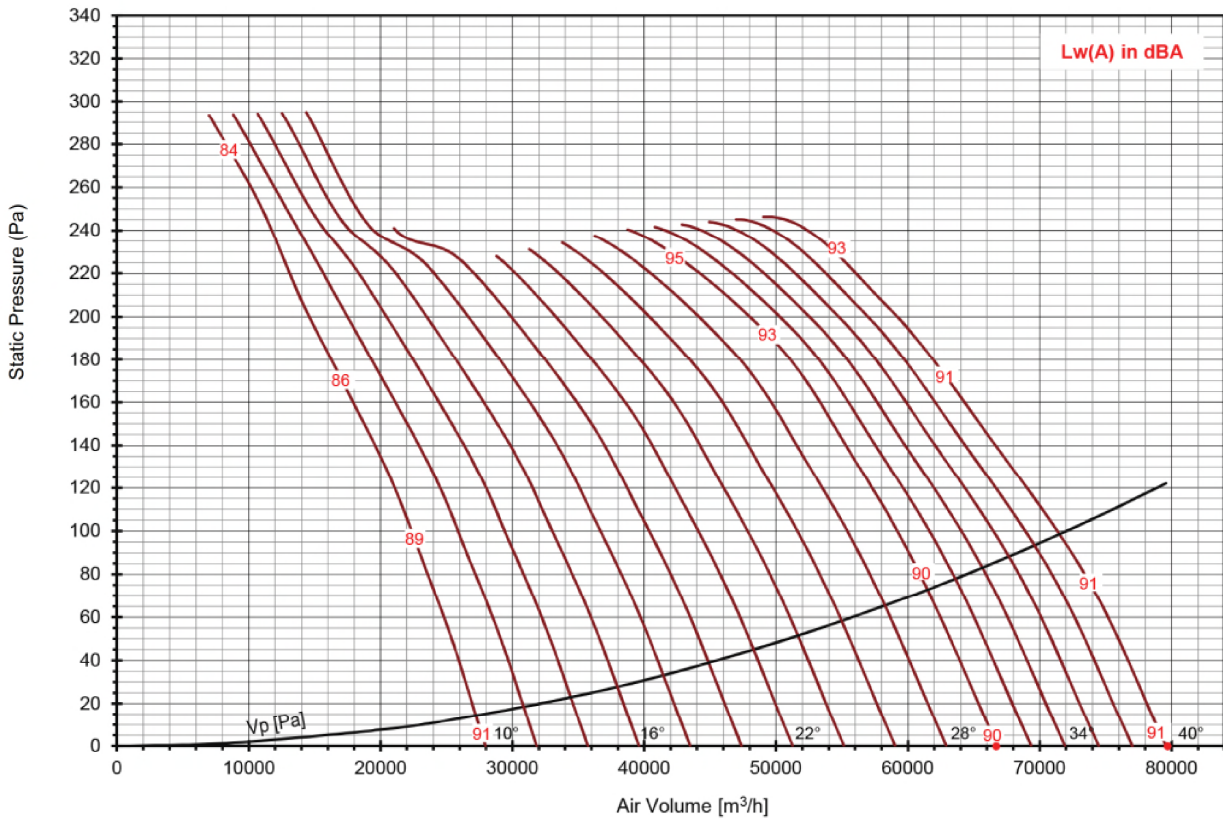
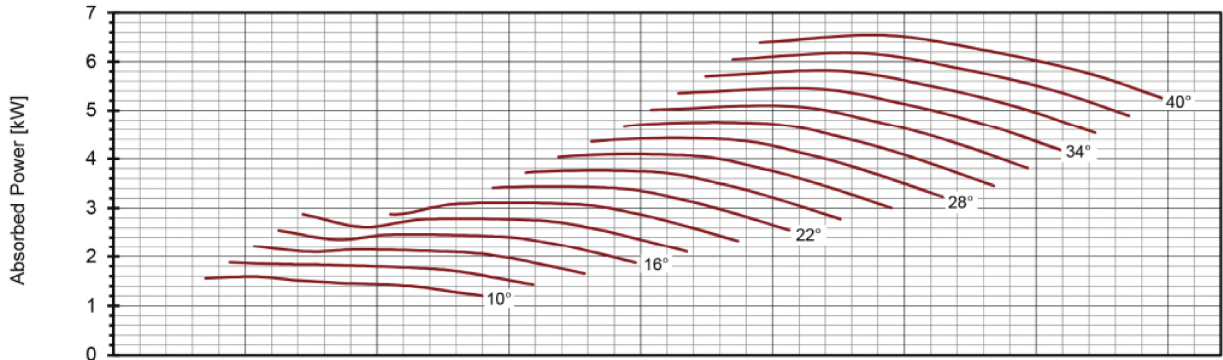

Peak Absorbed Power (kW)

N (rpm)	Blade Pitch Angle																Lp(A) at 3m	
	10°	12°	14°	16°	18°	20°	22°	24°	26°	28°	30°	32°	34°	36°	38°	40°		
580 motor	1.59	1.89	2.22	2.54	2.87	3.09	3.41	3.74	4.07	4.40	4.73	5.09	5.45	5.81	6.18	6.54	-20	
	2.2		3			4				5.5			7.5					

* Performance certified is for installation type B - Free Inlet, Ducted Outlet. Performance ratings do not include the effects of appurtenances (accessories).

* The A-weighted sound ratings shown have been calculated per AMCA International Standard 301. Values shown are for outlet LwoA sound power levels for installation type B: free inlet ducted outlet. Ratings include the effects of duct end correction.

* Lp(A) - dBA Levels are not licensed by AMCA International.



SERIES TFA 1600/420/11/V

Impeller Code : 1600/420
 Size : 1600mm
 Outlet Area : 2.011m²

Adjustable Pitch Angle Vane Axial Fan

FEG71

50Hz
1440 rpm

$\rho = 1.2\text{kg/m}^3$

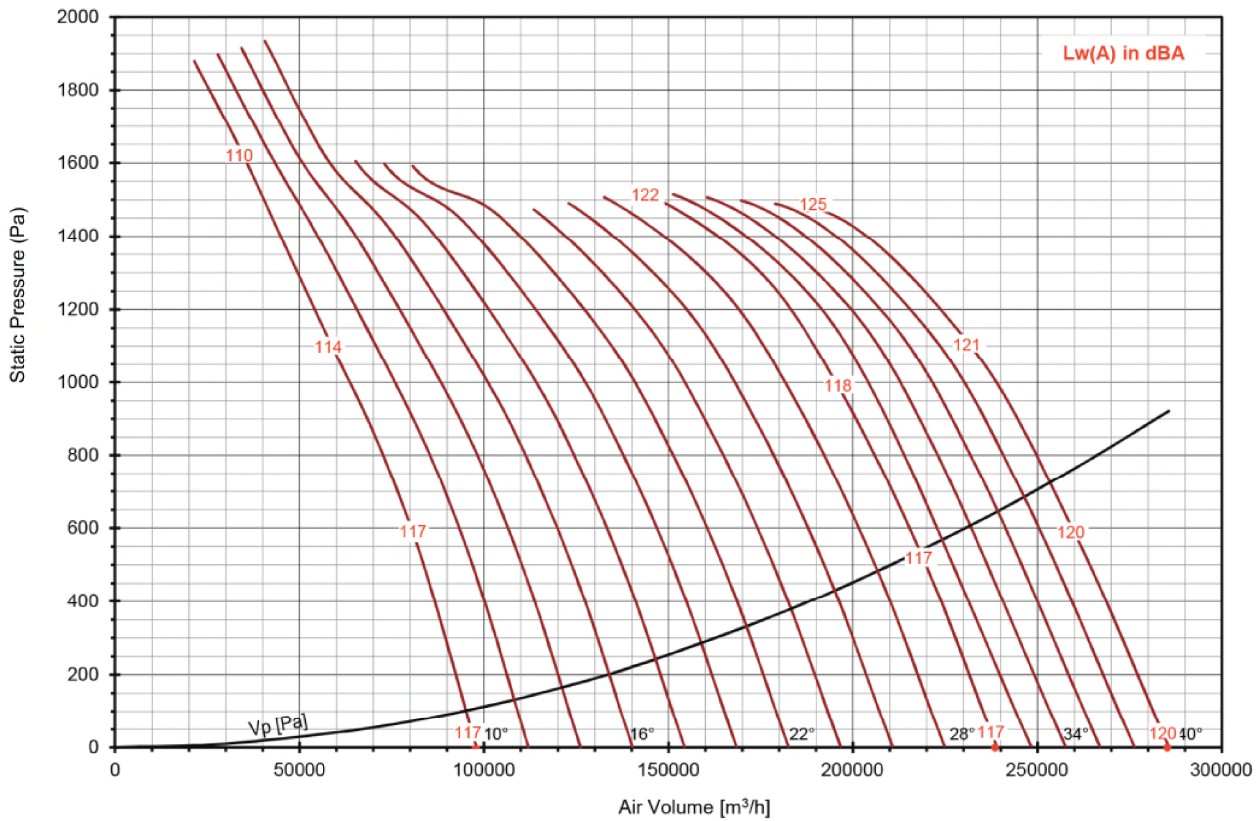
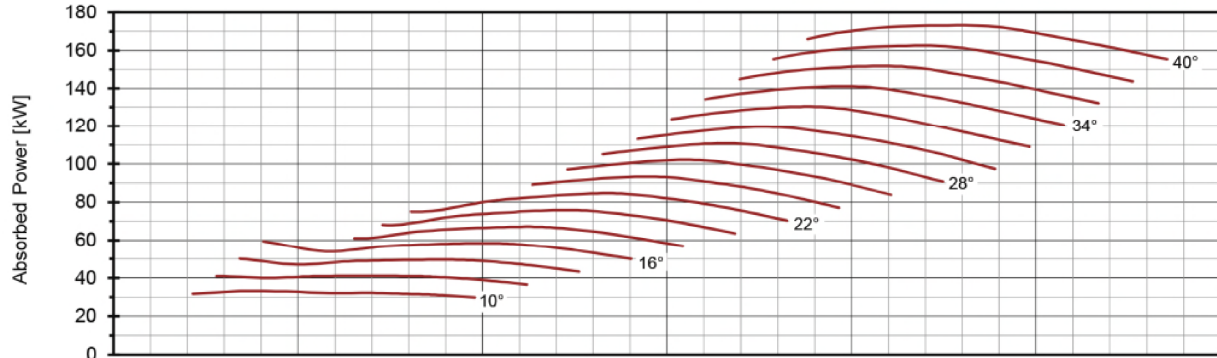

Peak Absorbed Power (kW)

N (rpm)	Blade Pitch Angle												Lp(A) at 3m				
	10°	12°	14°	16°	18°	20°	22°	24°	26°	28°	30°	32°		34°	36°	38°	40°
1440	33.0	40.9	50.2	59.4	67.1	75.9	84.6	93.4	102.1	110.8	119.6	130.3	141.1	151.8	162.5	173.3	-20
motor	37	45	55	75	90	110	132	160	200								

* Performance certified is for installation Type A - Free Inlet, Free Outlet with partition. Performance ratings do not include the effects of appurtenances (accessories)

* The A-weighted sound ratings shown have been calculated per AMCA International Standard 301. Values shown are for outlet LwoA sound power levels for installation type A: free inlet, free outlet with partition

* Lp(A) - dBA Levels are not licensed by AMCA International



SERIES TFA 1600/420/11/V

Impeller Code : 1600/420
 Size : 1600mm
 Outlet Area : 2.011m²

Adjustable Pitch Angle Vane Axial Fan

FEG71

50Hz
 960 rpm

$\rho = 1.2\text{kg/m}^3$

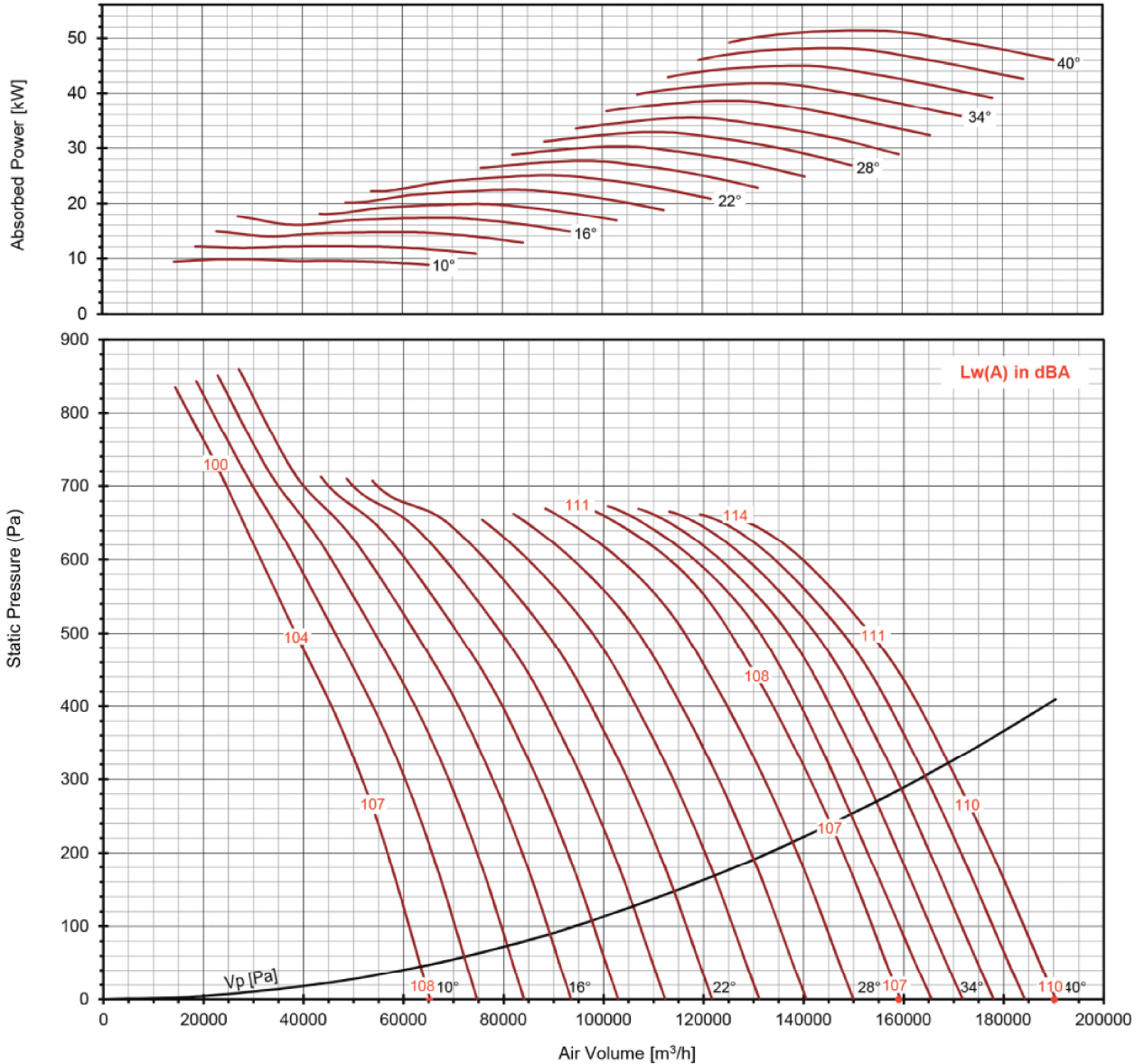

Peak Absorbed Power (kW)

N (rpm)	Blade Pitch Angle														Lp(A) at 3m		
	10°	12°	14°	16°	18°	20°	22°	24°	26°	28°	30°	32°	34°	36°		38°	40°
960	9.8	12.1	14.9	17.6	19.9	22.5	25.1	27.7	30.3	32.8	35.4	38.6	41.8	45.0	48.2	51.3	-20
motor	11	15	18.5	22	30	37	45	55									

* Performance certified is for installation Type A - Free Inlet, Free Outlet with partition. Performance ratings do not include the effects of appurtenances (accessories)

* The A-weighted sound ratings shown have been calculated per AMCA International Standard 301. Values shown are for outlet LwoA sound power levels for installation type A: free inlet, free outlet with partition

* Lp(A) - dBA Levels are not licensed by AMCA International



SERIES TFA 1600/420/11/V

Impeller Code : 1600/420
 Size : 1600mm
 Outlet Area : 2.011m²

Adjustable Pitch Angle Vane Axial Fan

FEG71

50Hz
720 rpm

$\rho = 1.2\text{kg/m}^3$

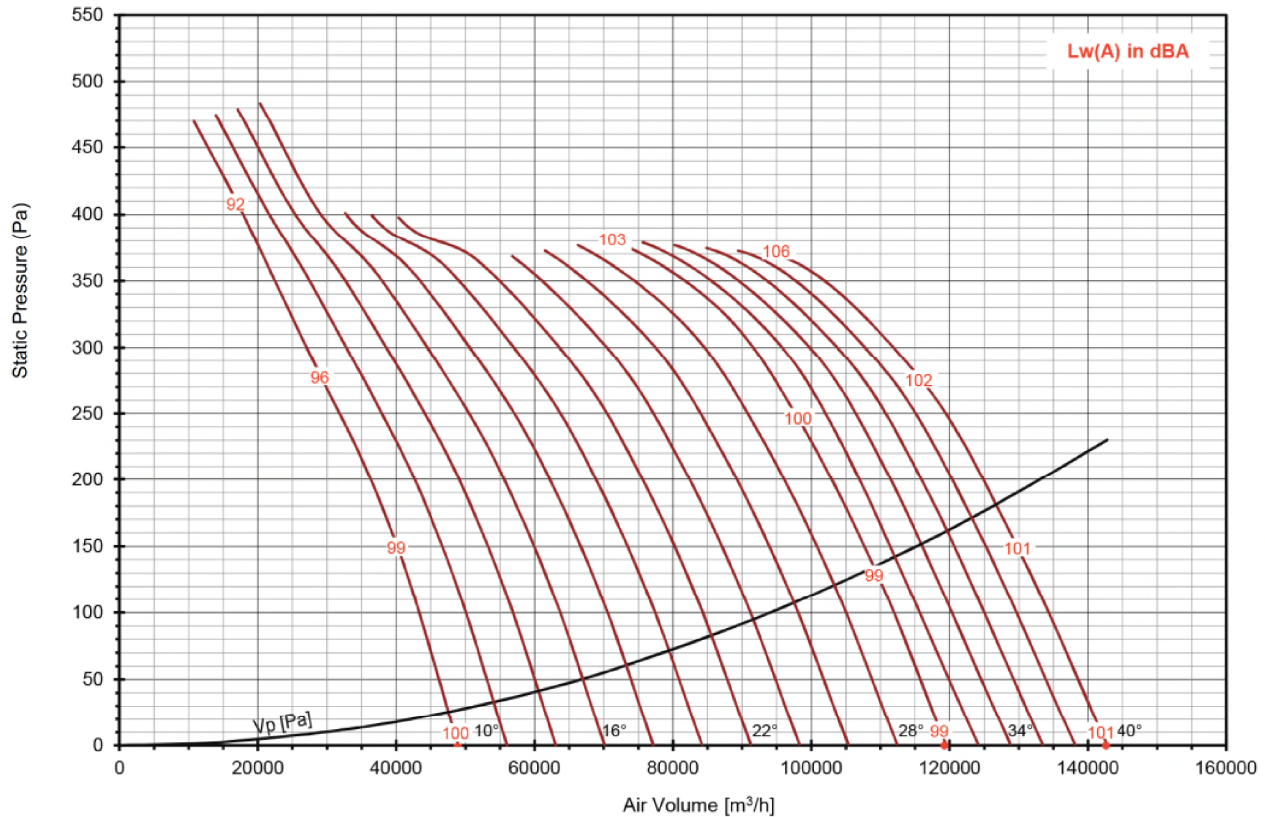
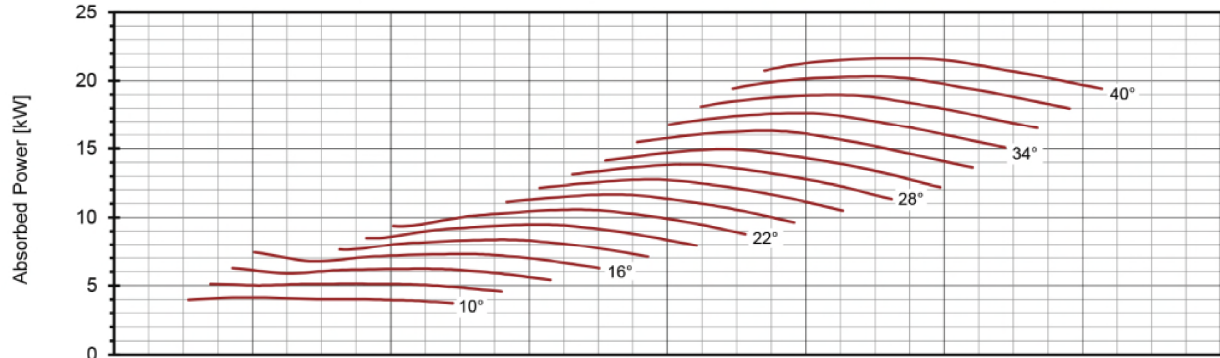

Peak Absorbed Power (kW)

N (rpm)	Blade Pitch Angle														Lp(A) at 3m		
	10°	12°	14°	16°	18°	20°	22°	24°	26°	28°	30°	32°	34°	36°		38°	40°
720	4.13	5.12	6.27	7.42	8.39	9.49	10.58	11.67	12.76	13.86	14.95	16.29	17.63	18.97	20.32	21.66	-20
motor		5.5		7.5		11			15			18.5			22		

* Performance certified is for installation Type A - Free Inlet, Free Outlet with partition.
 Performance ratings do not include the effects of appurtenances (accessories)

* The A-weighted sound ratings shown have been calculated per AMCA International Standard 301. Values shown are for outlet L_woA sound power levels for installation type A: free inlet, free outlet with partition

* Lp(A) - dBA Levels are not licensed by AMCA International



SERIES TFA 1600/420/11/V

Impeller Code : 1600/420
 Size : 1600mm
 Outlet Area : 2.011m²

Adjustable Pitch Angle Vane Axial Fan

FEG71

50Hz
580 rpm

$\rho = 1.2\text{kg/m}^3$

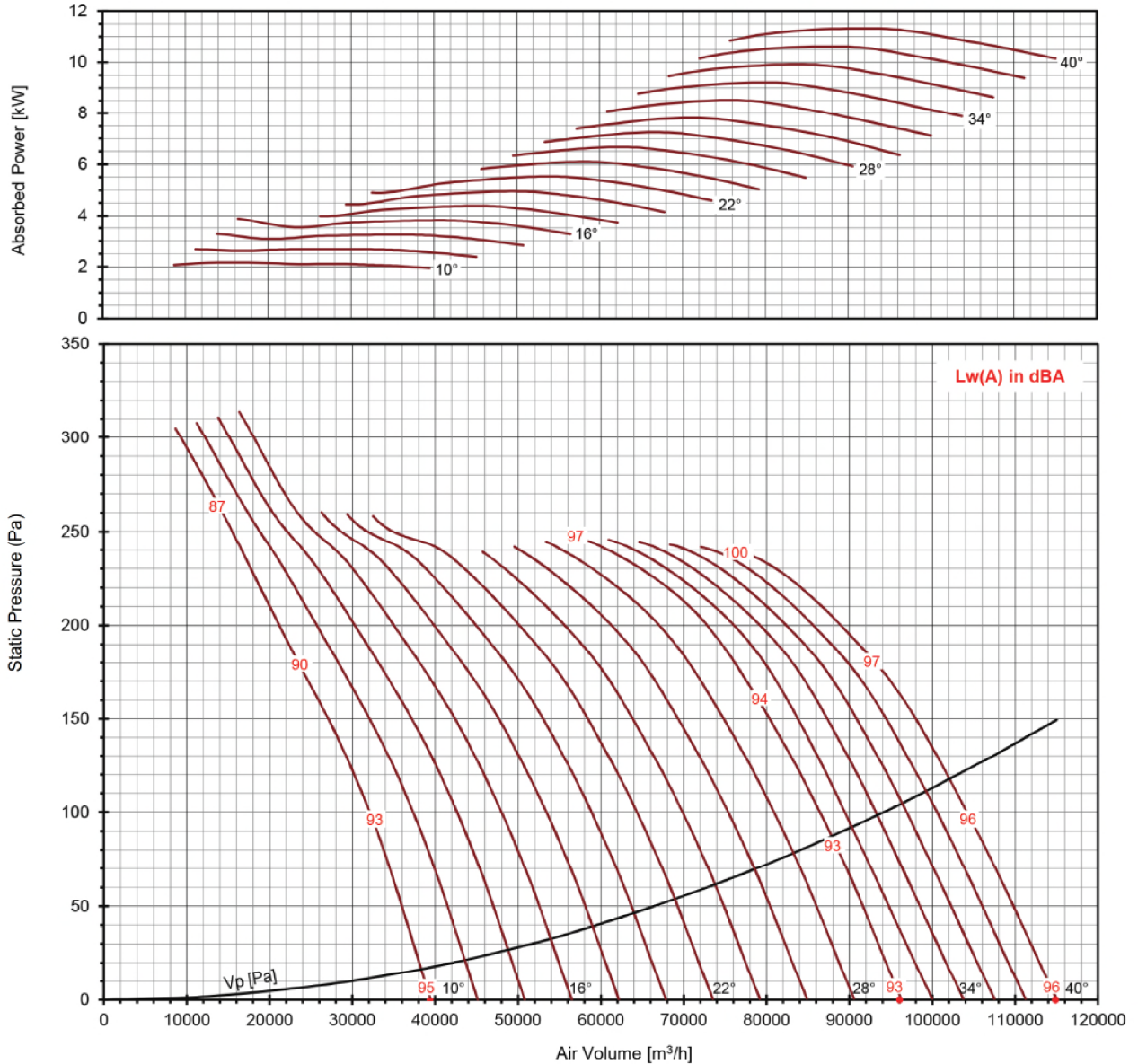

Peak Absorbed Power (kW)

N (rpm)	Blade Pitch Angle														Lp(A) at 3m		
	10°	12°	14°	16°	18°	20°	22°	24°	26°	28°	30°	32°	34°	36°		38°	40°
580	2.16	2.67	3.28	3.88	4.39	4.96	5.53	6.10	6.67	7.24	7.81	8.52	9.22	9.92	10.62	11.32	-20
motor	2.2	3	4		5.5			7.5					11			15	

* Performance certified is for installation Type A - Free Inlet, Free Outlet with partition. Performance ratings do not include the effects of appurtenances (accessories)

* The A-weighted sound ratings shown have been calculated per AMCA International Standard 301. Values shown are for outlet LwoA sound power levels for installation type A: free inlet, free outlet with partition

* Lp(A) - dBA Levels are not licensed by AMCA International



TFA V Series Dimensions

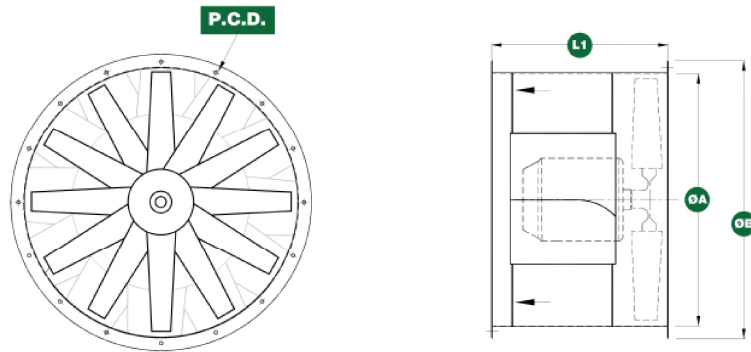

All Dimension in mm

Size	Electric Motor (kW)			ØA	ØB	ØD	Flange Size	PCD	No. of Holes	Approx. Weight (kg), L1	Approx. Weight (kg), L2	Max Motor Frame Size
	6P	4P	2P									
TFA 630/250/14/V	-	-	-	460	630	720	678	45	12	12	41	112M
	-	-	7.50	530	630	720	678	45	12	12	44	132S
	-	-	15.00	650	630	720	678	45	12	12	53	160M
TFA 800/250/14/V	-	-	18.50	695	630	720	678	45	12	12	56	160L
	1.50	3.00	-	495	800	900	856	50	12	12	64	100L
	2.20	4.00	-	495	800	900	856	50	12	12	64	112M
	3.00	5.50	-	530	800	900	856	50	12	12	67	132S
	-	7.50	-	565	800	900	856	50	12	12	70	132M
TFA 800/350/12/V	-	15.00	18.50	650	800	900	856	50	12	12	78	160L
	-	-	22.00	715	800	900	856	50	12	12	85	180M
	-	-	37.00	825	800	900	856	50	12	12	100	200L
	1.50	3.00	-	515	800	900	856	50	12	12	66	100L
	2.20	4.00	-	515	800	900	856	50	12	12	66	112M
TFA 800/300/10/V	3.00	5.50	-	550	800	900	856	50	12	12	68	132S
	-	7.50	-	585	800	900	856	50	12	12	71	132M
	-	15.00	-	670	800	900	856	50	12	12	80	160L
	-	-	37.00	845	800	900	856	50	12	12	102	200L
	5.50	7.50	-	645	1000	1100	1056	50	12	12	113	132M
TFA 1000/350/12/V	7.50	11.00	-	670	1000	1100	1056	50	12	12	115	160M
	-	15.00	-	670	1000	1100	1056	50	12	12	116	160L
	-	18.50	-	735	1000	1100	1056	50	12	12	121	180M
	-	22.00	-	780	1000	1100	1056	50	12	12	126	180L
	-	30.00	-	845	1000	1100	1056	50	12	12	136	200L
TFA 1000/300/10/V	5.50	7.50	-	645	1000	1100	1056	50	12	12	113	132M
	7.50	11.00	-	670	1000	1100	1056	50	12	12	115	160M
	-	15.00	-	670	1000	1100	1056	50	12	12	116	160L
	-	18.50	-	735	1000	1100	1056	50	12	12	121	180M
	-	22.00	-	780	1000	1100	1056	50	12	12	126	180L
TFA 1120/300/10/V	-	30.00	-	845	1000	1100	1056	50	12	12	136	200L
	15.00	22.00	-	815	1120	1220	1176	50	16	15	179	180L
	22.00	30.00	-	845	1120	1220	1176	50	16	15	182	200L
	-	37.00	-	885	1120	1220	1176	50	16	15	184	225S
	-	45.00	-	910	1120	1220	1176	50	16	15	187	225M
TFA 1120/350/12/V	-	55.00	-	1000	1120	1220	1176	50	16	15	199	250M
	15.00	22.00	-	815	1120	1220	1176	50	16	15	TBA	180L
	22.00	30.00	-	845	1120	1220	1176	50	16	15	TBA	200L
	-	37.00	-	885	1120	1220	1176	50	16	15	TBA	225S
	-	45.00	-	910	1120	1220	1176	50	16	15	TBA	225M
TFA 1250/350/12/V	-	55.00	-	1000	1120	1220	1176	50	16	15	TBA	250M
	15.00	22.00	-	815	1250	1350	1306	50	16	15	200	180L
	22.00	30.00	-	845	1250	1350	1306	50	16	15	203	200L
	-	37.00	-	885	1250	1350	1306	50	16	15	205	225S
	-	45.00	-	910	1250	1350	1306	50	16	15	209	225M
TFA 1400/350/12/V	-	55.00	-	1000	1250	1350	1306	50	16	15	222	250M
	30.00	45.00	-	915	1400	1510	1456	55	16	15	244	225M
	-	55.00	-	1000	1400	1510	1456	55	16	15	264	250M
	-	90.00	-	1065	1400	1510	1456	55	16	15	275	280M
	-	110.00	-	1305	1400	1510	1456	55	16	15	311	315S
TFA 1400/420/11/V	37.00	45.00	-	955	1400	1510	1456	55	16	15	29	225M
	-	55.00	-	1040	1400	1510	1456	55	16	15	268	250M
	-	90.00	-	1105	1400	1510	1456	55	16	15	280	280M
	-	110.00	-	1305	1400	1510	1456	55	16	15	311	315S
	-	132.00	-	1375	1600	1720	1656	60	24	20	434	315M
TFA 1600/420/11/V	-	200.00	-	1475	1600	1720	1656	60	24	20	459	315L
	30.00	45.00	-	970	1600	1720	1656	60	24	20	337	225M
	37.00	55.00	-	1040	1600	1720	1656	60	24	20	356	250M
	55.00	90.00	-	1105	1600	1720	1656	60	24	20	372	280M
	-	110.00	-	1305	1600	1720	1656	60	24	20	413	315S

* The actual dimension is subject to the motor frame size used, kindly refer to GTG Technical Submittal for further details.

* Weight indicated above excluded the weight of motor, hub and fan blades.

GTG[®]



SCAN & VISIT OUR WEBSITE

GTG Industries Sdn Bhd

(Formerly known as Grand Everise Sdn Bhd)
(912584-W)

**No. 13, Jalan Astaka U8/88B,
Seksyen U8, Bukit Jelutong,
40150 Shah Alam, Selangor.**

TEL +603-7859 0213/0216/0217 **FAX** +603-7859 0218

EMAIL inquiry@gtg.com.my **WEBSITE** www.gtg.com.my



Catalog ID: GTG/TFAV/R7
JANUARY 2024