

## Application

The VCD-40 is a low leakage control damper with extruded aluminum airfoil blades. Blades are completely contained within the frame allowing the damper to be directly mounted to a louver, filter frame, or similar application with no blade interference.

VCD-40 is IECC (International Energy Conservation Code) compliant with a leakage rating of 3 cfm/ft<sup>2</sup> at 1 in. wg (55cmh/m<sup>2</sup> at .25 kPa) or less.

## Damper Ratings

### Velocity

Up to 6000 fpm (30.5 m/s)

### Pressure

Up to 6 in. wg (1.5 kPa) - pressure differential

### Leakage

Class 1A at 1in. wg (0.25 kPa)

### Temperature

-40°F to 250°F (-40°C to 121°C). Consult factory for higher temperature

## Construction

	Standard	Optional
<b>Frame Material</b>	Aluminum	-
<b>Frame Material Thickness</b>	.125 in. (3.2 mm) minimum wall thickness	-
<b>Frame Type</b>	4 in. x 1 in. (102 mm x 25 mm) hat channel	Single flange, Reversed flange
<b>Blade Material</b>	Extruded Aluminum (6063T5)	-
<b>Blade Type</b>	Airfoil	-
<b>Blade Action</b>	Opposed	Parallel
<b>Blade Seals</b>	TPE	Silicone
<b>Linkage</b>	Plated steel out of airstream, concealed in jamb	316SS
<b>Axle Bearings</b>	Synthetic	316SS
<b>Axle Material</b>	½ in. dia. Plated steel	316SS
<b>Jamb Seal</b>	Stainless Steel	-
<b>Paint Finishes</b>	Mill Finish	Baked Enamel, Hi Pro Polyester, Industrial Epoxy Kynar/Hylar (70% Kynar) Anodize



\* W and H dimension furnished approximately ¼ in. (6 mm) undersize. If the height is 6 inches, the damper will be undersized an ⅛ in. (3 mm).

## Size Limitations

W x H	Minimum Size	Maximum Size	
		Single Section	Multiple Section
<b>Inches</b>	6 x 6	60 x 74	Unlimited
<b>mm</b>	152 x 152	1524 x 1880	Unlimited

Note: When more than one section wide, sections will be 48 in. wide (1219 mm).

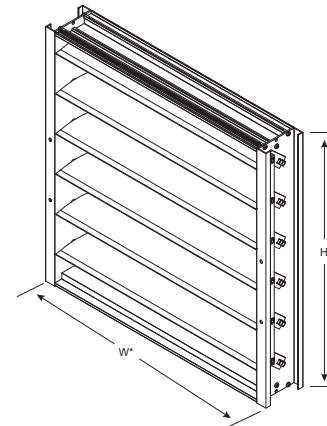

## Notes:

- Low profile head and sill are used on sizes less than 17 in. (432 mm) high
- Electric actuator and manual quadrant available. Factory supplied actuators are sized for 1500 fpm (7 m/s) and fully closed differential pressure of 2 in. wg (.5 kPa). Contact factory for actuator sizing on applications exceeding those limits.
- In applications where airflow could be uneven, such as a discharge fan, it is imperative to verify that at no point the maximum velocity exceeds the damper's cataloged velocity.
- Blades must be horizontal for either horizontal or vertical mount.

## Blade Operation

**Parallel blade operation** - this configuration requires the damper blades to rotate in the same direction, parallel to one another.

**Opposed blade operation** - adjacent damper blades rotate opposite one another.

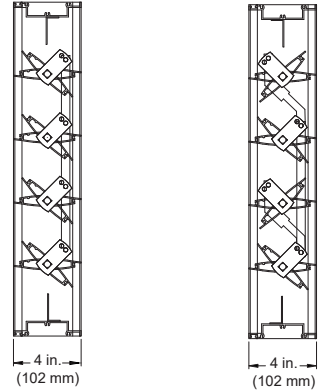

## Options

- Actuators (24V, 120V, manual, pull chain)
- Actuator mounting (external, external kit (field assembly), internal)
- Flanges
- NEMA enclosures (3, 4, 4X)
- Retaining angles
- Transformers

### Frame Options

#### Channel Frame

The channel frame option is designed for in-duct or slip-in installation. Dampers with external actuators can be rotated in the field 180 degrees to change from right hand to left hand drive (not recommended on parallel blade dampers).

Scan the QR code or click on the link “More Info” for more information on single flange and reverse flange.



[MORE INFO](#)

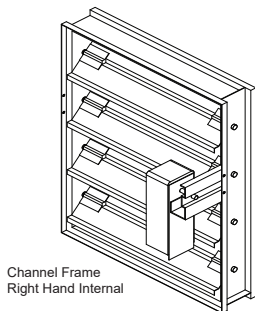

Channel Frame  
Right Hand Internal

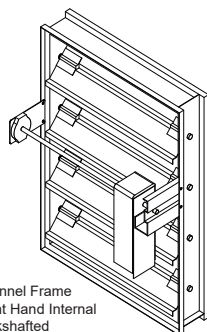

Channel Frame  
Right Hand Internal  
Jackshafted

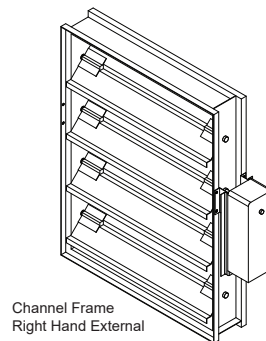

Channel Frame  
Right Hand External

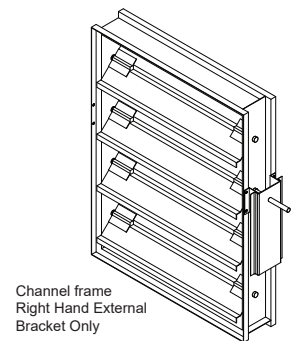

Channel frame  
Right Hand External  
Bracket Only

# Pressure Drop Data

## AMCA 5.2

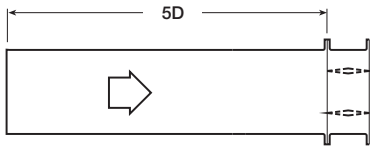

12 in. x 12 in. (305 mm x 305 mm)

Velocity (fpm)	Pressure Drop (in. wg)
500	0.08
1000	0.31
1500	0.69
2000	1.19
2500	1.84
3000	2.67
3500	3.59
4000	4.64

24 in. x 24 in. (610 mm x 610 mm)

Velocity (fpm)	Pressure Drop (in. wg)
500	0.01
1000	0.05
1500	0.11
2000	0.19
2500	0.30
3000	0.43
3500	0.58
4000	0.76

36 in. x 36 in. (914 mm x 914 mm)

Velocity (fpm)	Pressure Drop (in. wg)
500	0.01
1000	0.04
1500	0.09
2000	0.16
2500	0.24
3000	0.35
3500	0.48
4000	0.62

12 in. x 48 in. (305 mm x 1219 mm)

Velocity (fpm)	Pressure Drop (in. wg)
500	0.01
1000	0.05
1500	0.11
2000	0.20
2500	0.30
3000	0.43
3500	0.59
4000	0.77

48 in. x 12 in. (1219 mm x 305 mm)

Velocity (fpm)	Pressure Drop (in. wg)
500	0.06
1000	0.23
1500	0.52
2000	0.91
2500	1.43
3000	2.05
3500	2.82
4000	3.69

## AMCA 5.3

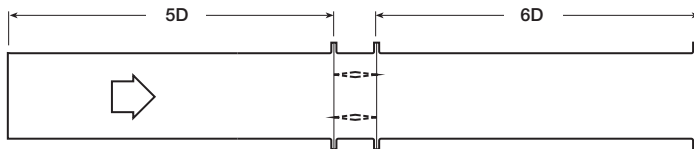

12 in. x 12 in. (305 mm x 305 mm)

Velocity (fpm)	Pressure Drop (in. wg)
500	0.05
1000	0.20
1500	0.45
2000	0.76
2500	1.19
3000	1.70
3500	2.29
4000	2.97

24 in. x 24 in. (610 mm x 610 mm)

Velocity (fpm)	Pressure Drop (in. wg)
500	0.01
1000	0.02
1500	0.05
2000	0.10
2500	0.15
3000	0.22
3500	0.30
4000	0.40

36 in. x 36 in. (914 mm x 914 mm)

Velocity (fpm)	Pressure Drop (in. wg)
500	0.01
1000	0.02
1500	0.04
2000	0.07
2500	0.10
3000	0.15
3500	0.20
4000	0.27

12 in. x 48 in. (305 mm x 1219 mm)

Velocity (fpm)	Pressure Drop (in. wg)
500	0.01
1000	0.03
1500	0.07
2000	0.12
2500	0.19
3000	0.26
3500	0.36
4000	0.46

48 in. x 12 in. (1219 mm x 305 mm)

Velocity (fpm)	Pressure Drop (in. wg)
500	0.03
1000	0.13
1500	0.29
2000	0.51
2500	0.81
3000	1.16
3500	1.59
4000	2.09

## AMCA 5.5

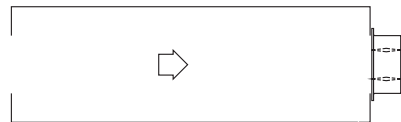

12 in. x 12 in. (305 mm x 305 mm)

Velocity (fpm)	Pressure Drop (in. wg)
500	0.1
1000	0.40
1500	0.88
2000	1.54
2500	2.41
3000	3.45
3500	4.75
4000	6.09

24 in. x 24 in. (610 mm x 610 mm)

Velocity (fpm)	Pressure Drop (in. wg)
500	0.03
1000	0.12
1500	0.29
2000	0.52
2500	0.80
3000	1.14
3500	1.60
4000	2.14

36 in. x 36 in. (914 mm x 914 mm)

Velocity (fpm)	Pressure Drop (in. wg)
500	0.03
1000	0.11
1500	0.26
2000	0.46
2500	0.72
3000	1.04
3500	1.43
4000	1.87

12 in. x 48 in. (305 mm x 1219 mm)

Velocity (fpm)	Pressure Drop (in. wg)
500	0.03
1000	0.12
1500	0.27
2000	0.49
2500	0.76
3000	1.11
3500	1.53
4000	2.00

48 in. x 12 in. (1219 mm x 305 mm)

Velocity (fpm)	Pressure Drop (in. wg)
500	0.08
1000	0.29
1500	0.63
2000	1.12
2500	1.76
3000	2.52
3500	3.40
4000	4.52



Greenheck Fan Corporation certifies that the model VCD-40 shown herein is licensed to bear the AMCA Seal. The ratings shown are based on tests and procedures performed in accordance with AMCA Publication 511 and comply with the requirements of the AMCA Certified Ratings Programs. The AMCA Certified Ratings Seal applies to air performance ratings only.

## Leakage

Air leakage is based on operation between 32°F (0°C) and 120°F (49°C).

Tested for leakage in accordance with ANSI/AMCA Standard 500-D, Figure 5.5.

Tested for air performance in accordance with ANSI/AMCA Standard 500-D, Figures 5.2, 5.3, and 5.5.

## Torque

Data are based on torque of 5.0 in. lb./ft<sup>2</sup> (0.56 N·m) applied to close and seat the damper during the test.

VCD-40 Maximum Damper Width	Leakage Class*					
	1 in. wg (0.25 kPa)	2 in. wg (0.5 kPa)	3 in. wg (0.75 in. wg)	4 in. wg (1 kPa)	5 in. wg (1.25 kPa)	6 in. wg (1.5 kPa)
36 in. (914 mm)	1A	1	1	1	1	1
48 in. (1219 mm)	1A	1	1	1	2	N/A
60 in. (1524 mm)	1A	2	2	N/A	N/A	N/A

### \*Leakage Class Definitions

The maximum allowable leakage is defined as the following:

- Leakage Class 1A - 3 cfm/ft<sup>2</sup> at 1 in. wg (class 1A is only defined at 1 in. wg).
- Leakage Class 1
  - 4 cfm/ft<sup>2</sup> at 1 in. wg
  - 8 cfm/ft<sup>2</sup> at 4 in. wg
  - 11 cfm/ft<sup>2</sup> at 8 in. wg
  - 12.6 cfm/ft<sup>2</sup> at 10 in. wg

## Temperature Limitations

Blade Seal	Temperature Range
TPE	-10°F to 200°F (-23°C to 93°C)
Silicone	-40°F to 250°F (-40°C to 121°C)

## Space Envelopes

On dampers less than 18 in. (457 mm) high, actuators may also require clearances above and/or below the damper frame. “B” and “T” dimensions are worst case clearance requirements for some dampers less than 18 in. (457 mm) high. All damper sizes under 18 in. (457mm) high do not require these worst case clearances. If space availability above or below the damper is limited, each damper size should be individually evaluated.

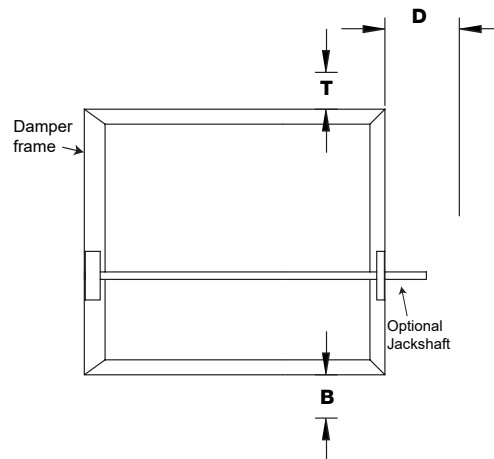

Actuator Type/Model	Height Inches (mm)	T	B Inches (mm)	D
AFBUP (-S) and FSNF Series, Belimo MSxx20 Series, Honeywell	≥6 to <10 (≥152 to <254)	0	12¾ (324)	6¼ (159)
	≥10 to <18 (≥254 to <457)	0	2 (51)	6¼ (159)
	≥18 (457)	0	0	6¼ (159)
FSLF, LF and TFB Series, Belimo	≥6 to <10 (≥152 to <254)	0	3½ (89)	6¼ (159)
	≥10 (≥254)	0	0	6¼ (159)
MSxx04 & MSxx09 Series, Honeywell	≥6 to <9 (≥152 to <229)	0	4¾ (121)	6¼ (159)
	≥9 (229)	0	0	6¼ (159)
MS75xx Series, Honeywell	≥6 to <10 (≥152 to <254)	0	12¾ (324)	6¼ (159)
	≥10 to <18 (≥254 to <457)	0	7 (178)	6¼ (159)
	≥18 (457)	0	0	6¼ (159)
GRD and GVD Series, Siemens	≥6 to <10 (≥152 to <254)	0	12¾ (324)	6¼ (159)
	≥10 to <18 (≥254 to <457)	0	2 (51)	6¼ (159)
	≥18 (457)	0	0	6¼ (159)
GJD Series, Siemens	≥6 to <10 (≥152 to <254)	0	3½ (89)	6¼ (159)
	≥10 to <18 (≥254 to <457)	0	0	6¼ (159)
	≥18 (457)	0	0	6¼ (159)

## Actuator Mounting

Actuators may be installed at the factory or shipped loose with the necessary linkage and brackets required for mounting. For more detail information on actuator mounting, click on link below or scan QR code.



[ACTUATOR MOUNTING](#)

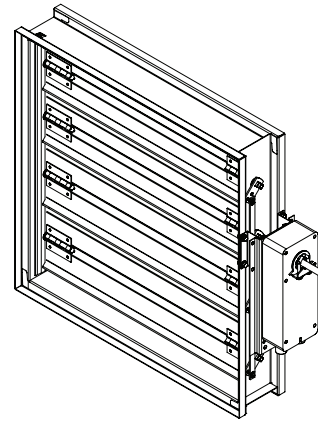

Non-jackshaft external right

## Clearance Requirements

This drawing depicts the worst case clearance requirements for an actuator with a jackshaft.

Internal mount only Actuator model	A	B	C
All except - EFB & EFCX Series	7 ¾ in (197 mm)	3 ¾ in (95 mm)	5 ⅝ in (137 mm)
EFB & EFCX Series	8 ½ in (216 mm)	6 in (152mm)	8 ½ in (216 mm)

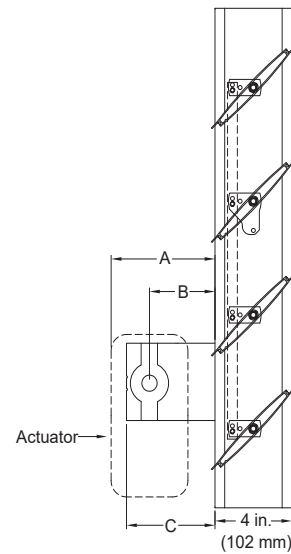

Dampers larger than the maximum single section size, will be made up of a multiple of equal size sections. Multiple section dampers can be jackshafted together so that all sections operate together as shown below.

**Note:** Dampers larger than 60 in. x 74 in. (1524 mm x 1880 mm) are not intended to be structurally self supporting. Refer to IOM document 483509 for structural support requirements on multi-section assemblies.

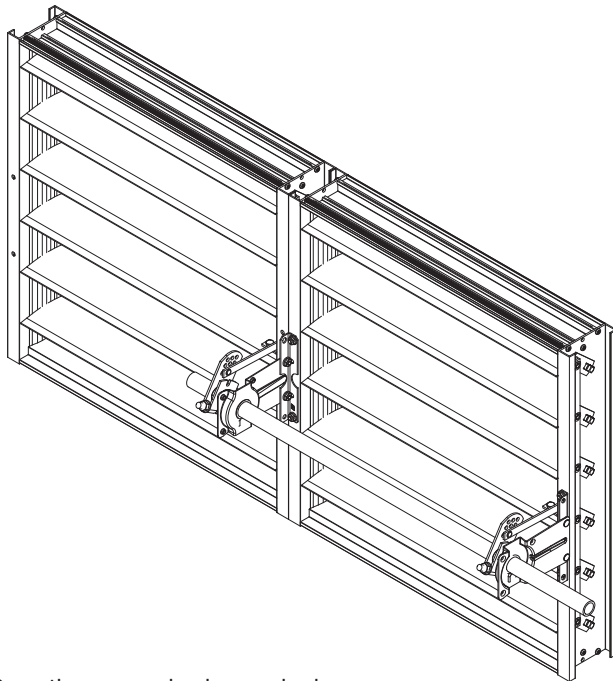

2 section example shows single jackshaft driving multiple sections

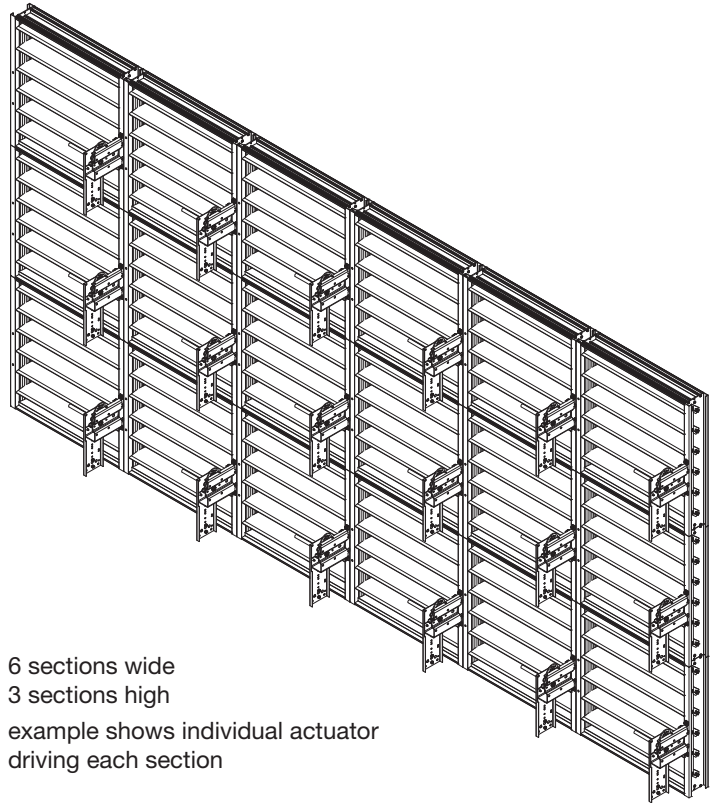

6 sections wide  
3 sections high  
example shows individual actuator driving each section

## Document Links



[INSTALLATION](#)



[CATALOG](#)



[SELECTION GUIDE](#)



[SPECIFICATIONS](#)



[WARRANTY](#)