

### Application

The VCD-33 is a low leakage damper with steel airfoil blades. The airfoil shape reduces pressure drop and turbulence in a HVAC system. The VCD-33 is intended for application in medium to high pressure and velocity systems.

This model is also IECC (International Energy Conservation Code) compliant with a leakage rating of 3 cfm/ft<sup>2</sup> at 1 in. wg (55 cmh/m<sup>2</sup> at .25 kPa) or less.

### Damper Ratings

#### Velocity

Up to 4000 fpm (20.3 m/s)

#### Pressure

Up to 8 in. wg (2 kPa) pressure differential  
For pressures greater than 8 in wg, consult factory.

#### Leakage

Class 1A at 1 in. wg (.25 kPa)  
Class 1 at 4 in. - 8 in. wg (1 kPa - 2 kPa)

#### Temperature

-40°F to 250°F (-40°C to 121°C). Consult factory for higher temperatures.



\* W&H dimension furnished approximately 1/4 in. (6 mm) undersize.

### Size Limitations

W x H	Minimum Size	Maximum Size	
		Single Section	Multiple Section
Inches	6 x 6	60 x 74	Unlimited
mm	152 x 152	1524 x 1880	Unlimited

### Construction

	Standard	Optional
<b>Frame Material</b>	Galvanized Steel	304SS
<b>Frame Thickness</b>	16 ga. (1.5 mm)	12 ga. (2.7 mm)*
<b>Frame Type</b>	5 in. x 1 in. (127 mm x 25 mm) hat channel	Single flange, Reversed flange, Double flange
<b>Blade Material</b>	Galvanized steel	304SS
<b>Blade Thickness</b>	2 skins of 20 ga. (1 mm)	-
<b>Blade Type</b>	Airfoil	-
<b>Blade Action</b>	Opposed	Parallel
<b>Linkage</b>	Plated steel out of airstream	316SS
<b>Axle Bearings</b>	Synthetic (acetal)	316SS
<b>Axle Material</b>	Plated steel	316SS
<b>Blade Seals</b>	TPE	Silicone
<b>Jamb Seals</b>	Stainless Steel	-

\*When 12 ga (2.7 mm) frame is selected and the damper height is less than 17 inches (432 mm), low profile top and bottom frame members are utilized. These low profile frame members will be made from 16 ga. (1.5 mm) material.

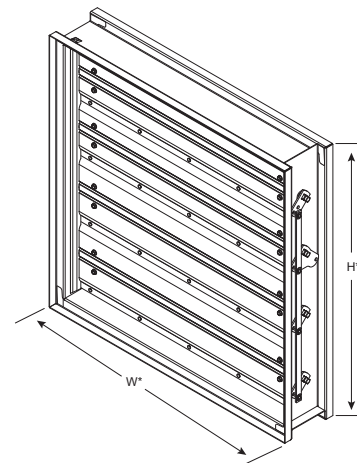

### Notes:

- Low profile head and sill are used on sizes less than 17 in (432 mm) high
- Linkage concealed in the frame
- Electric actuator and manual quadrant available. Factory supplied actuators are sized for 1500 fpm (7 m/s) and fully closed differential pressure of 2 in. wg (.5 kPa). contact factory for actuator sizing on applications exceeding those limits.
- In applications where airflow could be uneven, such as a discharge fan, it is imperative to verify that at no point the maximum velocity exceeds the damper's cataloged velocity.
- Blades must be horizontal for either horizontal or vertical mount. If you need vertical blades, see VCD-33V model.

# Blade Operation

**Parallel blade operation** - this configuration requires the damper blades to rotate in the same direction, parallel to one another.

**Opposed blade operation** - adjacent damper blades rotate opposite one another.

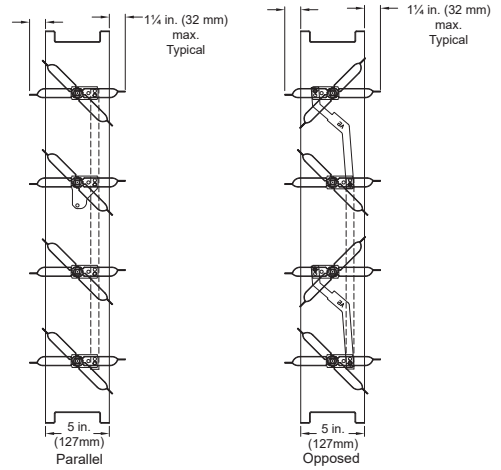

## Options

- Actuators (24V, 120V, manual, pull chain)
- Actuator mounting (external, external kit (field assembly), internal)
- Flanges
- Multi-section fastening
- NEMA enclosures (3, 4, 4X, 7)
- [OCI \(open or closed indicator\)](#)
- R Transition
- [Retaining angles](#)
- Sleeves
- Transformers

## Frame Options

### Channel Frame

The channel frame option is designed for in-duct or slip-in installation. Dampers with external actuators can be rotated in the field 180 degrees to change from right hand to left hand drive (not recommended on parallel blade dampers).

Scan the QR code or click on the link “More Info” for more information on single flange, reverse flange and double flange.



[MORE INFO](#)

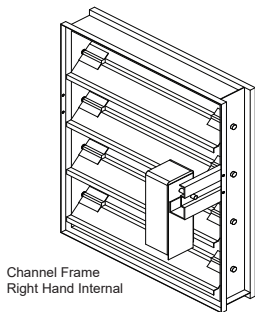

Channel Frame  
Right Hand Internal

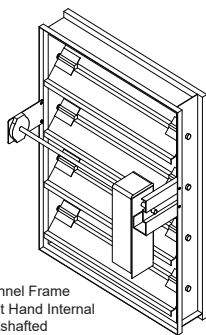

Channel Frame  
Right Hand Internal  
Jackshafted

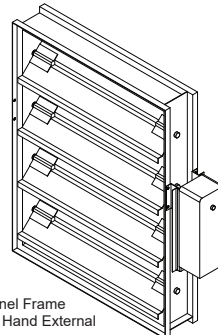

Channel Frame  
Right Hand External

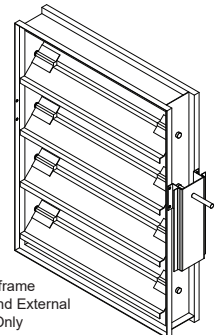

Channel frame  
Right Hand External  
Bracket Only

# AMCA Certified Pressure Drop Data



Greenheck Fan Corporation certifies that the model VCD-33 shown herein is licensed to bear the AMCA Seal. The ratings shown are based on tests and procedures performed in accordance with AMCA Publication 511 and comply with the requirements of the AMCA Certified Ratings Programs. The AMCA Certified Ratings Seal applies to Air Leakage and Air Performance ratings.

## AMCA 5.2

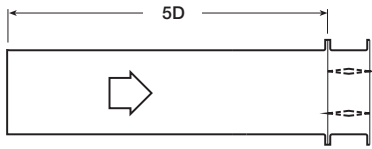

12 in. x 12 in. (305 mm x 305 mm)

Velocity (fpm)	Pressure Drop (in. wg)
500	0.01
1000	0.03
1500	0.07
2000	0.13
2500	0.19
3000	0.26
3500	0.35
4000	0.45

24 in. x 24 in. (610 mm x 610 mm)

Velocity (fpm)	Pressure Drop (in. wg)
500	0.01
1000	0.03
1500	0.06
2000	0.10
2500	0.15
3000	0.21
3500	0.28
4000	0.36

36 in. x 36 in. (914 mm x 914 mm)

Velocity (fpm)	Pressure Drop (in. wg)
500	0.01
1000	0.02
1500	0.04
2000	0.07
2500	0.11
3000	0.15
3500	0.20
4000	0.26

12 in. x 48 in. (305 mm x 1219 mm)

Velocity (fpm)	Pressure Drop (in. wg)
500	0.01
1000	0.03
1500	0.07
2000	0.11
2500	0.17
3000	0.23
3500	0.31
4000	0.39

48 in. x 12 in. (1219 mm x 305 mm)

Velocity (fpm)	Pressure Drop (in. wg)
500	0.01
1000	0.02
1500	0.04
2000	0.08
2500	0.12
3000	0.16
3500	0.21
4000	0.27

## AMCA 5.3

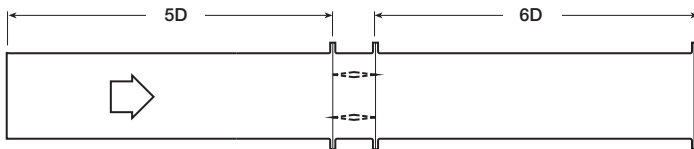

12 in. x 12 in. (305 mm x 305 mm)

Velocity (fpm)	Pressure Drop (in. wg)
500	0.01
1000	0.02
1500	0.05
2000	0.08
2500	0.12
3000	0.17
3500	0.23
4000	0.30

24 in. x 24 in. (610 mm x 610 mm)

Velocity (fpm)	Pressure Drop (in. wg)
500	0.01
1000	0.01
1500	0.03
2000	0.05
2500	0.09
3000	0.13
3500	0.17
4000	0.22

36 in. x 36 in. (914 mm x 914 mm)

Velocity (fpm)	Pressure Drop (in. wg)
500	0.01
1000	0.01
1500	0.02
2000	0.04
2500	0.06
3000	0.08
3500	0.12
4000	0.15

12 in. x 48 in. (305 mm x 1219 mm)

Velocity (fpm)	Pressure Drop (in. wg)
500	0.01
1000	0.02
1500	0.04
2000	0.08
2500	0.12
3000	0.17
3500	0.22
4000	0.29

48 in. x 12 in. (1219 mm x 305 mm)

Velocity (fpm)	Pressure Drop (in. wg)
500	0.01
1000	0.02
1500	0.04
2000	0.07
2500	0.11
3000	0.15
3500	0.20
4000	0.25

## AMCA 5.5

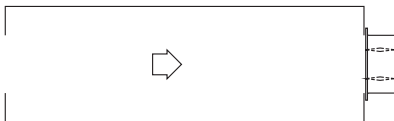

12 in. x 12 in. (305 mm x 305 mm)

Velocity (fpm)	Pressure Drop (in. wg)
500	0.03
1000	0.12
1500	0.27
2000	0.48
2500	0.74
3000	1.07
3500	1.46
4000	1.91

24 in. x 24 in. (610 mm x 610 mm)

Velocity (fpm)	Pressure Drop (in. wg)
500	0.03
1000	0.11
1500	0.26
2000	0.45
2500	0.71
3000	1.02
3500	1.40
4000	1.89

36 in. x 36 in. (914 mm x 914 mm)

Velocity (fpm)	Pressure Drop (in. wg)
500	0.02
1000	0.09
1500	0.21
2000	0.38
2500	0.58
3000	0.85
3500	1.15
4000	1.52

12 in. x 48 in. (305 mm x 1219 mm)

Velocity (fpm)	Pressure Drop (in. wg)
500	0.03
1000	0.11
1500	0.24
2000	0.43
2500	0.67
3000	0.96
3500	1.31
4000	1.71

48 in. x 12 in. (1219 mm x 305 mm)

Velocity (fpm)	Pressure Drop (in. wg)
500	0.03
1000	0.11
1500	0.24
2000	0.44
2500	0.68
3000	0.97
3500	1.32
4000	1.73

## AMCA Certified Leakage Data

Air leakage is based on operation between 32°F (0°C) and 120°F (49°C).

Tested for leakage in accordance with ANSI/AMCA Standard 500-D, Figure 5.5.

Tested for air performance in accordance with ANSI/AMCA Standard 500-D, Figures 5.2, 5.3 and 5.5.

## Torque

Data are based on a torque of 7.0 in. lb./ft<sup>2</sup> (0.79 N·m) applied to close and seat the damper during the test.

VCD-33 Maximum Damper Width	Leakage Class*		
	1 in. wg (0.25 kPa)	4 in. wg (1 kPa)	8 in. wg (2 kPa)
60 in. (1524 mm)	1A	1	1



Greenheck Fan Corporation certifies that the model VCD-33 shown herein is licensed to bear the AMCA Seal. The ratings shown are based on tests and procedures performed in accordance with AMCA Publication 511 and comply with the requirements of the AMCA Certified Ratings Programs. The AMCA Certified Ratings Seal applies to Air Leakage and Air Performance ratings.

### \*Leakage Class Definitions

The maximum allowable leakage is defined by AMCA as the following:

- Leakage Class 1A - 3 cfm/ft<sup>2</sup> at 1 in. wg (class 1A is only defined at 1 in. wg).
- Leakage Class 1
  - 4 cfm/ft<sup>2</sup> at 1 in. wg
  - 8 cfm/ft<sup>2</sup> at 4 in. wg
  - 11 cfm/ft<sup>2</sup> at 8 in. wg
  - 12.6 cfm/ft<sup>2</sup> at 10 in. wg

## Velocity Limitations

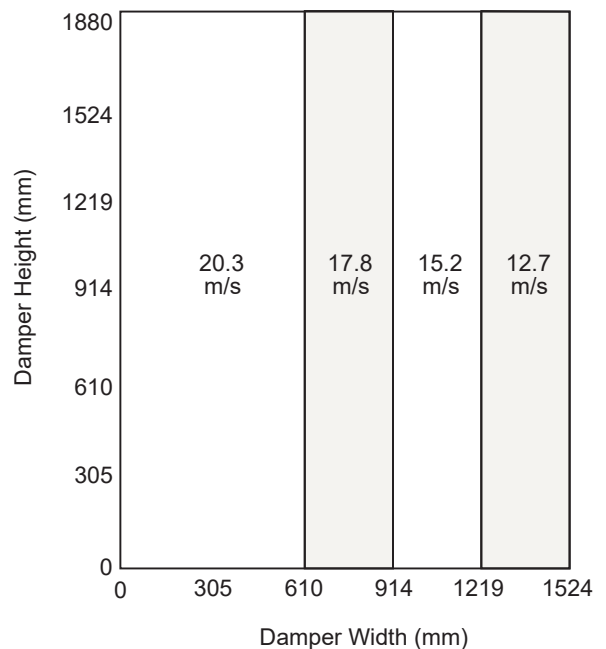
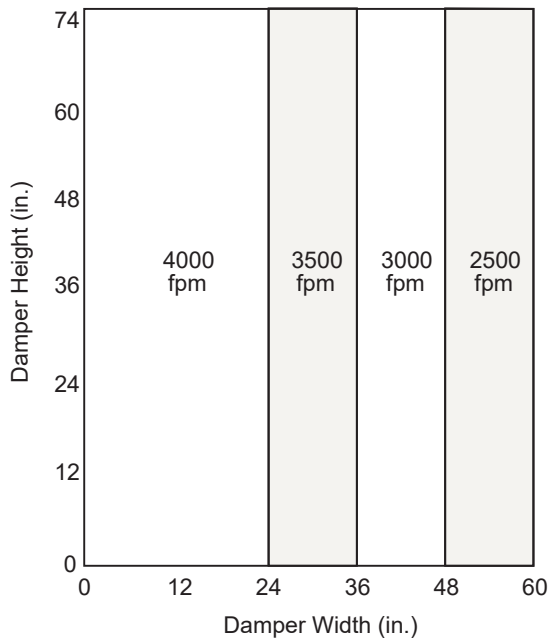

## Temperature Limitations

Blade Seal	Temperature Range
TPE	-10°F to 200°F (-23°C to 93°C)
Silicone	-40°F to 250°F (-40°C to 121°C)

## Space Envelopes

On dampers less than 18 in. (457 mm) high, actuators may also require clearances above and/or below the damper frame. “B” and “T” dimensions are worst case clearance requirements for some dampers less than 18 in. (457 mm) high. All damper sizes under 18 in. (457 mm) high do not require these worst case clearances. If space availability above or below the damper is limited, each damper size should be individually evaluated.

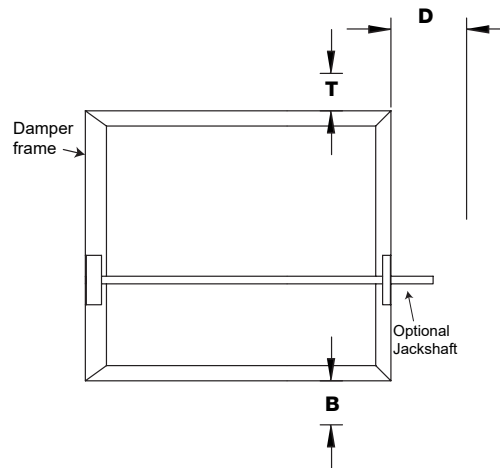

Actuator Type/Model	Height Inches (mm)	T	B Inches (mm)	D
AFBUP (-S) and FSNF Series, Belimo MSxx20 Series, Honeywell	≥6 to <10 (≥152 to <254)	0	12¾ (324)	6¼ (159)
	≥10 to <18 (≥254 to <457)	0	2 (51)	6¼ (159)
	≥18 (457)	0	0	6¼ (159)
FSLF, LF and TFB Series, Belimo	≥6 to <10 (≥152 to <254)	0	3½ (89)	6¼ (159)
	≥10 (≥254)	0	0	6¼ (159)
MSxx04 & MSxx09 Series, Honeywell	≥6 to <9 (≥152 to <229)	0	4¾ (121)	6¼ (159)
	≥9 (229)	0	0	6¼ (159)
MS75xx Series, Honeywell	≥6 to <10 (≥152 to <254)	0	12¾ (324)	6¼ (159)
	≥10 to <18 (≥254 to <457)	0	7 (178)	6¼ (159)
	≥18 (457)	0	0	6¼ (159)
GRD and GVD Series, Siemens	≥6 to <10 (≥152 to <254)	0	12¾ (324)	6¼ (159)
	≥10 to <18 (≥254 to <457)	0	2 (51)	6¼ (159)
	≥18 (457)	0	0	6¼ (159)
GJD Series, Siemens	≥6 to <10 (≥152 to <254)	0	3½ (89)	6¼ (159)
	≥10 to <18 (≥254 to <457)	0	0	6¼ (159)
	≥18 (457)	0	0	6¼ (159)

## Actuator Mounting

Actuators may be installed at the factory, shipped loose with the necessary linkage and brackets for mounting, or field supplied. For more detail information on actuator mounting, click on link below or scan QR code.



[ACTUATOR MOUNTING](#)

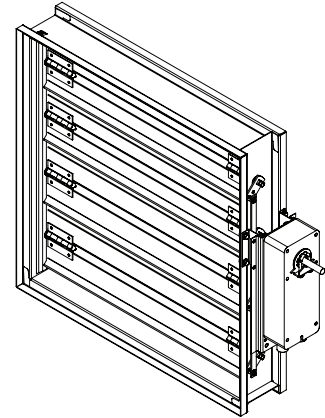

**Non-jackshaft external right**

## Clearance Requirements

This drawing depicts the worse case clearance requirements for an actuator with a jackshaft.

Internal mount only Actuator model	A	B	C
All except - EFB & EFCX Series	7 ¾ in (197 mm)	3 ¾ in (95 mm)	5 ⅜ in (136.5 mm)
EFB & EFCX Series	8 ½ in (216 mm)	6 in (152 mm)	8 ½ in (216 mm)

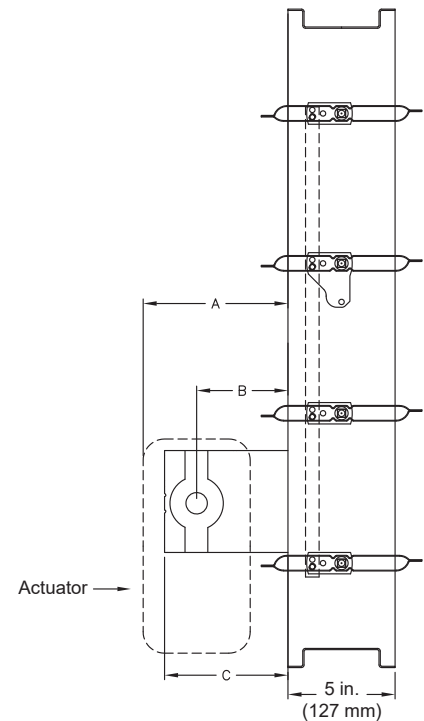

## Multi-Section Dampers

Dampers larger than the maximum single section size, will be made up of a multiple of equal size sections.

**NOTE:** Dampers larger than 60 in. x 74 in. (1524 mm x 1880 mm) are not intended to be structurally self supporting. Refer to IOM document 463384 for structural support requirements on multi-section assemblies.

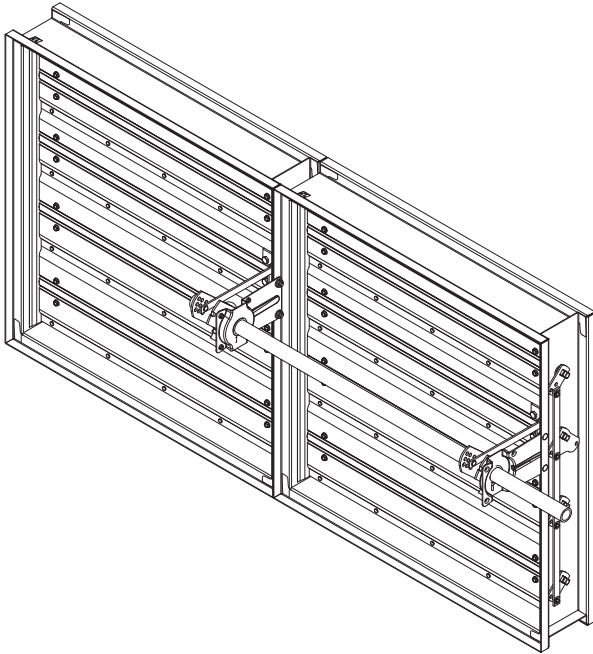

2 section example shows single jackshaft driving multiple sections

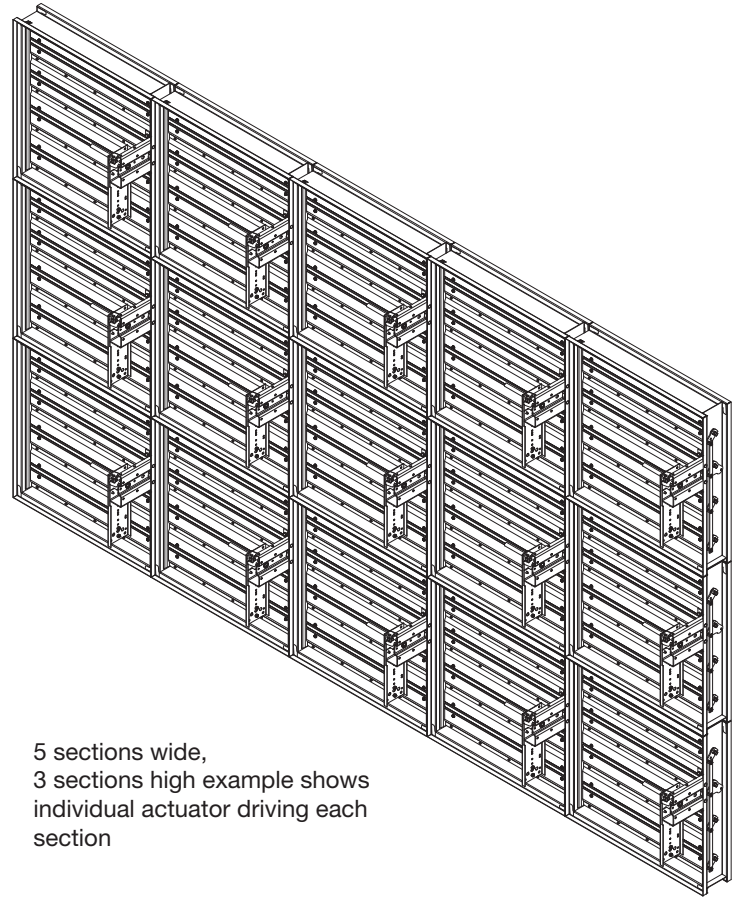

5 sections wide,  
3 sections high example shows  
individual actuator driving each  
section

## Document Links



[INSTALLATION](#)



[CATALOG](#)



[SELECTION GUIDE](#)



[SPECIFICATIONS](#)



[WARRANTY](#)