

Application

Model DFD-210 is a dynamic rated multi-blade fire damper with 3V style blades. The DFD-210 may be installed vertically (with blades running horizontal) or horizontally and is rated for airflow in either direction.

This model has a manual quadrant which allows the DFD-210 to function as both a fire damper and a manual balancing damper.

Ratings

UL 555 Fire Resistance Rating

Fire Rating: 1½ hours

Dynamic Closure Rating: Actual ratings are size dependent

Velocity: Up to 4000 fpm (20.3 m/s)

Pressure: Up to 10 in. wg (2.5 kPa)

Construction

	Standard	Optional
Frame Material	Galvanized steel	-
Frame Material Thickness	16 ga. (1.5mm)	-
Frame Type	5 in. x 1 in. (127 mm x 25 mm) hat channel	-
Blade Material	Galvanized steel	-
Blade Material Thickness	16 ga. (1.5 mm)	-
Blade Type	3V	-
Blade Action	Parallel	-
Linkage	Plated steel out of airstream, concealed in jamb	-
Axle Bearings	316SS	-
Axle Material	Plated steel	-
Jamb Seals	Stainless Steel	-
Closure Device	Fusible link	-
Closure Temperature	165°F (74°C)	212°F (100°C), 286°F (141°C)*, 350°F (177°C)
Actuator	Manual quadrant	-

Note:

The frames are constructed with reinforced corners. Low profile head and sill are used on sizes less than 17 in. (432 mm) high for lower pressure drop and improved damper performance.

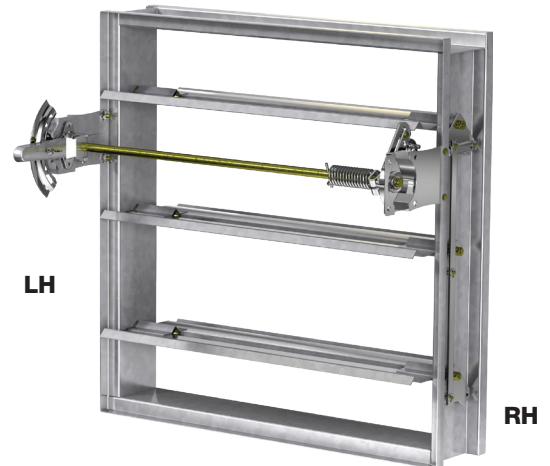

W & H dimensions furnished approximately ¼ in. (6 mm) undersize. Add sleeve thickness for overall sleeved damper dimension.



See complete marking on product.

UL 555 Classification R13317

CAN/ULC S112 Classified Fire Damper

Model DFD-210 meets the requirements for fire dampers established by:

National Fire Protection Association

NFPA Standards 80, 90A, & 101

IBC International Building Codes

CSFM California State Fire Marshal

Fire Damper Listing (#3225-0981:0103)

W x H	Minimum Size	Maximum Size	
		Single Section	Multiple Section
		Horizontal	Vertical
2000 fpm (10.2 m/s) 4 in.wg (1 kPa)			
Inches	8 x 6	36 x 36 or 32 x 50	128 x 96 128 x 100
mm	203 x 152	914 x 914 or 813 x 1270	3251 x 2438 3251 x 2540
2000 fpm (10.2 m/s) > 4 in. wg (1 kPa)			
Inches	8 x 6	32 x 50	64 x 50 64 x 50
mm	203 x 152	813 x 1270	1626 x 1270 1626 x 1270
> 2000 fpm (20.3 m/s)			
Inches	8 x 6	32 x 50	- -
mm	203 x 152	813 x 1270	- -

Options

- [Breakaway connections](#)
- Clean wrap
- [Grille tabs](#)
- [OCI \(Open Closed Indication Switches\)*](#)
- [Retaining angles](#)
- [Security bars](#)
- Sealed Transition and sleeves
- Sleeves
- [Test Switch \(GTS-4\)](#)
- Transition (C, O, R)

*Note: Dampers more than one section wide will be furnished with a single OCI device per row when selected.

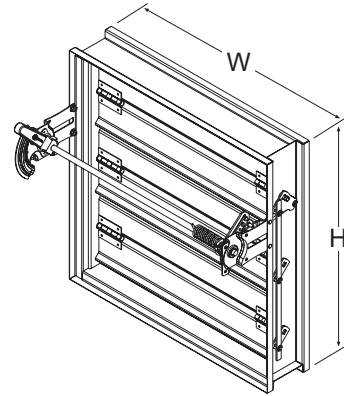

Transitioned Damper Dimensions

When a fire damper is being used in conjunction with round or oval ductwork, the DFD-210 can be supplied in a factory sleeve with round or oval transitions on both ends of the sleeve. Dampers should be ordered to the duct dimensions. Drawings below show overall damper size.

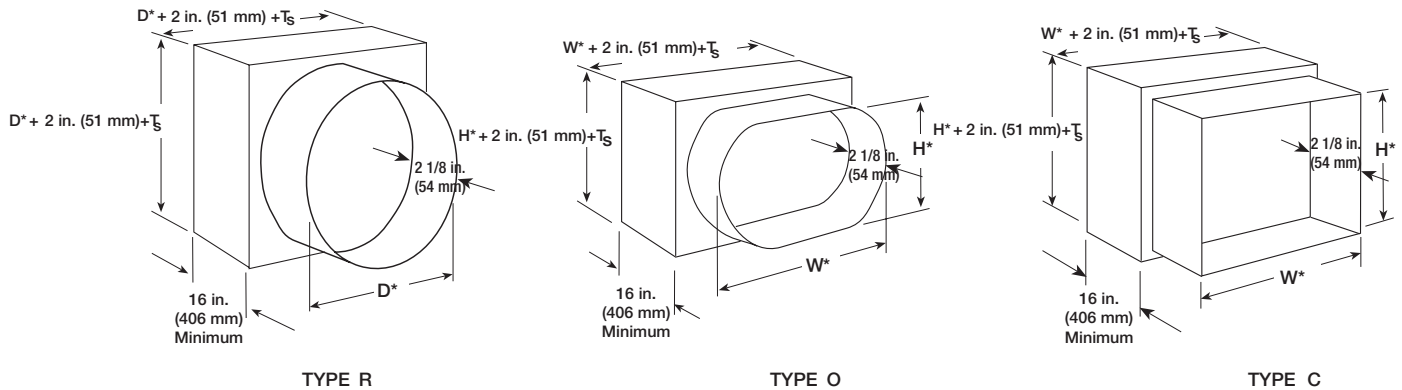

*These dimensions are furnished approximately 1/4 in. (6mm) undersize, except round and oval dimensions which are approximately 1/8 in. (3 mm) undersize.

$T_s = (2)(\text{Sleeve Thickness})$

Pressure Drop

AMCA Figure 5.2

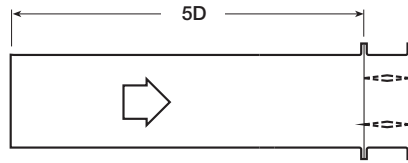

12 in. x 12 in. (305mm x 305mm)

Velocity (fpm)	Pressure Drop (in. wg)
500	0.04
1000	0.14
1500	0.31
2000	0.55
2500	0.86
3000	1.24
3500	1.69
4000	2.20

24 in. x 24 in. (610mm x 610mm)

Velocity (fpm)	Pressure Drop (in. wg)
500	0.02
1000	0.07
1500	0.16
2000	0.29
2500	0.45
3000	0.65
3500	0.89
4000	1.16

36 in. x 36 in. (914mm x 914mm)

Velocity (fpm)	Pressure Drop (in. wg)
500	0.01
1000	0.04
1500	0.09
2000	0.16
2500	0.25
3000	0.36
3500	0.49
4000	0.64

12 in. x 48 in. (305mm x 1219mm)

Velocity (fpm)	Pressure Drop (in. wg)
500	0.01
1000	0.06
1500	0.13
2000	0.23
2500	0.36
3000	0.52
3500	0.70
4000	0.92

48 in. x 12 in. (1219mm x 305mm)

Velocity (fpm)	Pressure Drop (in. wg)
500	0.03
1000	0.10
1500	0.23
2000	0.41
2500	0.63
3000	0.91
3500	1.24
4000	1.62

AMCA Figure 5.3

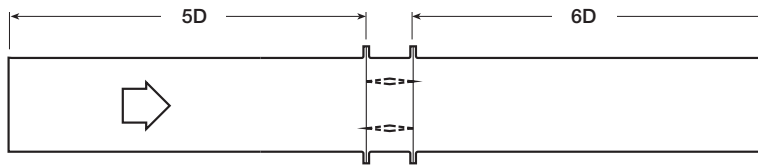

12 in. x 12 in. (305mm x 305mm)

Velocity (fpm)	Pressure Drop (in. wg)
500	0.02
1000	0.09
1500	0.20
2000	0.36
2500	0.56
3000	0.81
3500	1.10
4000	1.44

24 in. x 24 in. (610mm x 610mm)

Velocity (fpm)	Pressure Drop (in. wg)
500	0.01
1000	0.04
1500	0.09
2000	0.16
2500	0.25
3000	0.35
3500	0.48
4000	0.63

36 in. x 36 in. (914mm x 914mm)

Velocity (fpm)	Pressure Drop (in. wg)
500	0.01
1000	0.03
1500	0.06
2000	0.11
2500	0.17
3000	0.24
3500	0.33
4000	0.42

12 in. x 48 in. (305mm x 1219mm)

Velocity (fpm)	Pressure Drop (in. wg)
500	0.01
1000	0.04
1500	0.10
2000	0.17
2500	0.27
3000	0.39
3500	0.53
4000	0.70

48 in. x 12 in. (1219mm x 305mm)

Velocity (fpm)	Pressure Drop (in. wg)
500	0.02
1000	0.07
1500	0.16
2000	0.29
2500	0.45
3000	0.64
3500	0.88
4000	1.14

AMCA Figure 5.5

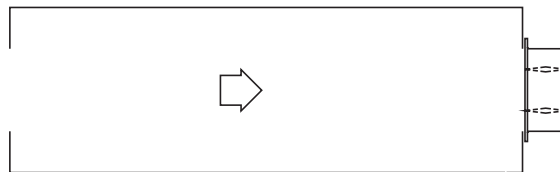

12 in. x 12 in. (305mm x 305mm)

Velocity (fpm)	Pressure Drop (in. wg)
500	0.06
1000	0.22
1500	0.50
2000	0.89
2500	1.39
3000	2.00
3500	2.72
4000	3.55

24 in. x 24 in. (610mm x 610mm)

Velocity (fpm)	Pressure Drop (in. wg)
500	0.03
1000	0.14
1500	0.31
2000	0.54
2500	0.85
3000	1.22
3500	1.66
4000	2.17

36 in. x 36 in. (914mm x 914mm)

Velocity (fpm)	Pressure Drop (in. wg)
500	0.03
1000	0.12
1500	0.26
2000	0.46
2500	0.73
3000	1.05
3500	1.42
4000	1.86

12 in. x 48 in. (305mm x 1219mm)

Velocity (fpm)	Pressure Drop (in. wg)
500	0.03
1000	0.13
1500	0.30
2000	0.53
2500	0.83
3000	1.19
3500	1.62
4000	2.11

48 in. x 12 in. (1219mm x 305mm)

Velocity (fpm)	Pressure Drop (in. wg)
500	0.04
1000	0.17
1500	0.38
2000	0.67
2500	1.04
3000	1.50
3500	2.05
4000	2.67



Greenheck Fan Corporation certifies that the model DFD-210 shown herein is licensed to bear the AMCA Seal. The ratings shown are based on tests and procedures performed in accordance with AMCA Publication 511 and comply with the requirements of the AMCA Certified Ratings Programs. The AMCA Certified Ratings Seal applies to air performance ratings only.

Space Envelopes

The drawings below and corresponding table show the position of the DFD-210 damper when mounted in a factory sleeve ("A" dimension). The standard mounting locations provide enough space for the mounting of manual quadrant(s) and allow space for installation of retaining angles and duct connections. The following options may affect the range of available mounting locations: transitions, security bars, grille tabs.

The standard location of a damper mounted in a factory sleeve ("A" dimension) is shown below. The damper can be positioned at other locations within a range of 7 3/16 in. (183 mm) to 16 in. (406 mm) for the "A" dimension.

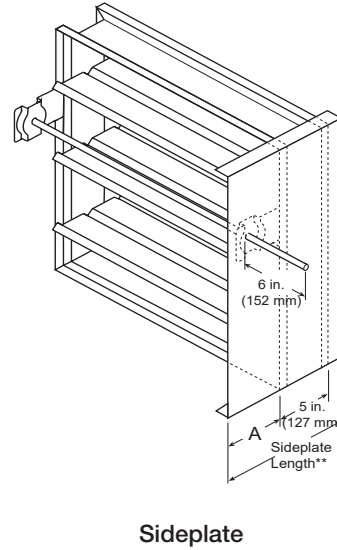
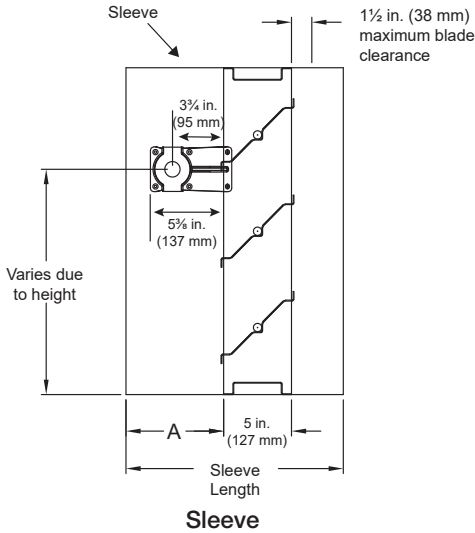

in. (mm)	"A" Dimension		
	Sleeve Std	Sleeve Max	Sideplate
Dampers with no OCI	7 3/16 in. (183)	16 (406)	6 3/16 (157)
Height <11 in. (279) with OCI	12 (305)	16 (406)	12 (305)
Height ≥ 11 in. (279) with OCI	7 3/16 in. (183)	16 (406)	6 3/16 (157)

NOTE: Entire damper frame is not required to be installed within the wall. The damper blades, when closed should be contained within the wall.

Multiple Section Dampers

Dampers larger than maximum single section size are supplied as a factory assembly of two or more sections of equal size. The following figures show maximum damper section size and assembly configurations for multi-section dampers.

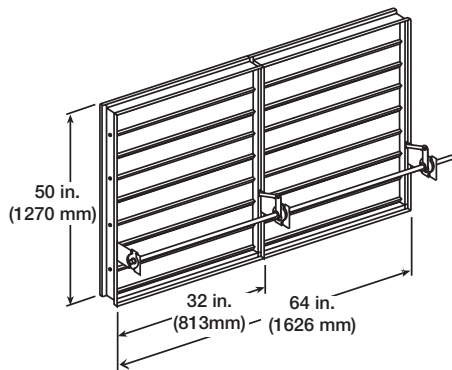

Two sections

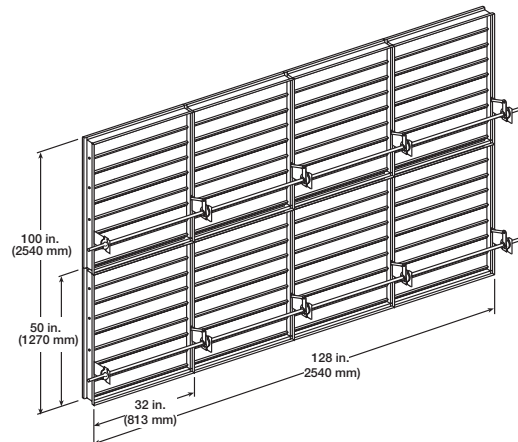

4 Sections wide
2 sections high



[INSTALLATION](#)



[CATALOG](#)



[SELECTION GUIDE](#)



[ALTERNATE INSTALLATIONS](#)



[WARRANTY](#)



[SPECIFICATIONS](#)