

ALL-LITE

EFD-645

Extruded Aluminum Louver
6" deep • 45° Drainable Blade

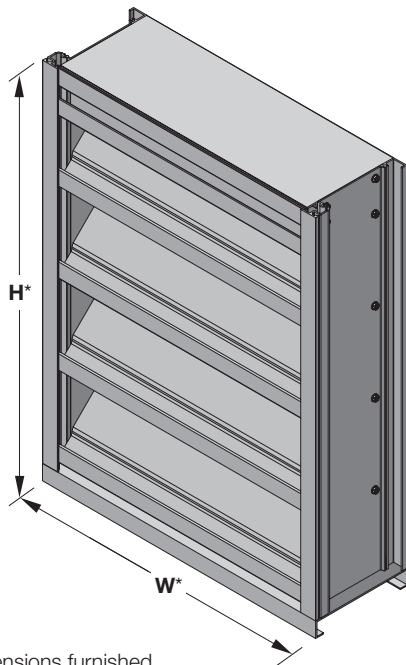

EFD-645 (standard)

*Louver dimensions furnished
approximately 1/2" (13) undersize.

Ratings

Free Area: [48" x 48" (1219 x 1219) unit]: 8.7 ft² (0.81 m²)
54.6%

Performance @ Beginning Point of Water Penetration

Free Area Velocity: 1,009 fpm (5.13 m/s)

Air Volume Delivered: 8,811 cfm (4.16 m³/s)

Pressure Loss: 0.13 in.wg. (32 Pa)

Velocity @ 0.15 in.wg. Pressure Loss: 1,092 fpm (5.55 m/s)

Std. Design Load: 30 psf



Certified Ratings:

All-Lite certifies that the model EFD-645 shown herein is licensed to bear the AMCA seal. The ratings shown are based on test and procedures performed in accordance with AMCA Publication 511 and comply with the requirements of the AMCA Certified Ratings Program. The AMCA Certified Ratings seal applies to air performance and water penetration ratings.

The EFD-645 drainable blade louver is designed to prevent water penetration in non-wind-driven rain applications by collecting water in frame and blade gutters and channeling it into downspouts and away from airflow paths. The EFD-645 is available in a wide array of anodized and painted finishes including custom color matching.

Standard Construction

Material: Mill finish 6063-T5 extruded aluminum

Frame: 6" deep x 0.081" thick (152 x 2) channel

Blades: 45° x 0.081" thick (2) drainable style

Screen: 1/2" x 0.063" (12.7 x 1.6) expanded and flattened aluminum

Mullion: Visible

Minimum Size: 4.5" x 8" (114 x 203)

Maximum Size:

Single section: 60" x 120" (1524 x 3048)

120" x 60" (3048 x 1524)

Multiple section: Unlimited

Options

■ Factory finish:

- High Performance Fluoropolymer
- Baked Enamel
- Prime Coat
- Clear Anodize
- Integral Color Anodize

■ Frame Options:

- 1-1/2" (38) flange frame
- Stucco flange
- Glazing frame

■ Installation Hardware

- Clip angles
- Continuous angles

■ Hidden Vertical Mullion

■ Alternate bird or insect screens

■ Insulated or non-insulated blank-off panels

■ Filter racks

■ Hinged frame

■ Subframe

■ Head and/or sill flashing

■ Burglar bars

■ Frame closure

■ Net OD (actual size)

5 year
warranty

NOTE: Dimensions in parentheses () are millimeters.
Information is subject to change without notice or obligation.

PERFORMANCE

EFD-645

Extruded Aluminum Louver
6" deep • 45° Drainable Blade

Free Area (ft²)

Width (Inches)

Height (Inches)	Width (Inches)																			
	4.5	12	18	24	30	36	42	48	54	60	66	72	78	84	90	96	102	108	114	120
7	0.0	0.1	0.1	0.1	0.2	0.2	0.2	0.3	0.3	0.3	0.4	0.4	0.4	0.5	0.5	0.6	0.6	0.6	0.7	0.7
12	0.1	0.2	0.4	0.5	0.6	0.8	0.9	1.0	1.2	1.3	1.4	1.6	1.7	1.8	2.0	2.1	2.2	2.4	2.5	2.6
18	0.1	0.5	0.7	1.0	1.3	1.6	1.8	2.1	2.4	2.7	3.0	3.2	3.5	3.8	4.1	4.3	4.6	4.9	5.2	5.5
24	0.2	0.8	1.3	1.7	2.2	2.7	3.2	3.7	4.1	4.6	5.1	5.6	6.0	6.5	7.0	7.5	7.9	8.4	8.9	9.4
30	0.3	1.1	1.7	2.4	3.0	3.7	4.3	5.0	5.6	6.3	6.9	7.6	8.3	8.9	9.6	10.2	10.9	11.5	12.2	12.8
36	0.3	1.4	2.2	3.0	3.9	4.7	5.5	6.3	7.2	8.0	8.8	9.6	10.5	11.3	12.1	12.9	13.8	14.6	15.4	16.3
42	0.4	1.7	2.7	3.6	4.6	5.6	6.6	7.6	8.6	9.6	10.6	11.6	12.6	13.6	14.6	15.6	16.3	17.6	18.6	19.6
48	0.5	1.9	3.0	4.2	5.3	6.5	7.6	8.7	9.9	11.0	12.1	13.3	14.4	15.6	16.7	17.8	19.0	20.1	21.3	22.4
54	0.5	2.1	3.4	4.7	6.0	7.3	8.5	9.8	11.1	12.4	13.7	15.0	16.2	17.5	18.8	20.1	21.4	22.7	23.9	25.2
60	0.6	2.4	3.8	5.2	6.7	8.1	9.5	10.9	12.4	13.8	15.2	16.6	18.1	19.5	20.9	22.3	23.8	25.2	26.6	28.0
66	0.7	2.7	4.3	6.0	7.6	9.2	10.8	12.5	14.1	15.7	17.3	19.0	20.6	22.2	23.8	25.5	27.1	28.7	30.3	32.0
72	0.7	3.0	4.8	6.6	8.4	10.2	12.0	13.8	15.6	17.4	19.2	21.0	22.8	24.6	26.4	28.2	30.0	31.8	33.6	35.4
78	0.8	3.3	5.3	7.2	9.2	11.2	13.2	15.1	17.1	19.1	21.1	23.3	25.0	27.0	29.0	30.9	32.9	34.9	36.9	38.8
84	0.9	3.6	5.7	7.9	10.0	12.1	14.3	16.4	18.6	20.7	22.9	25.0	27.2	29.3	31.4	33.6	35.7	37.9	40.0	42.2
90	1.0	3.8	6.1	8.4	10.7	13.0	15.2	17.5	19.8	22.1	24.4	26.7	29.0	31.3	33.5	35.8	38.1	40.4	42.7	45.0
96	1.0	4.1	6.5	8.9	11.3	13.8	16.2	18.6	21.1	23.5	25.9	28.4	30.8	33.2	35.6	38.1	40.5	42.9	45.4	47.8
102	1.1	4.3	6.9	9.4	12.0	14.6	17.2	19.7	22.3	24.9	27.5	30.0	32.6	35.2	37.8	40.3	42.9	45.5	48.1	50.6
108	1.2	4.6	7.4	10.2	12.9	15.7	18.5	21.3	24.0	26.8	29.6	32.4	35.1	37.9	40.7	43.4	46.2	49.0	51.8	54.5
114	1.2	4.9	7.9	10.8	13.8	16.7	19.7	22.6	25.6	28.5	31.4	34.4	37.3	40.3	43.2	46.2	49.1	52.1	55.0	58.0
120	1.3	5.2	8.3	11.5	14.6	17.7	20.8	23.9	27.1	30.2	33.3	36.4	39.6	42.7	45.8	48.9	52.1	55.2	58.3	61.4

Water Penetration

AMCA defines the beginning point of water penetration as the free area velocity at the intersection of a simple linear regression of test data and the line of 0.01 ounces of water per square foot of free area and is measured through a 48" x 48" louver during a 15 minute period. The AMCA water penetration test provides a method for comparing louver models and designs as to their efficiency in resisting the penetration of rainfall under specific lab conditions. We recommend that intake louvers are selected with a reasonable margin of safety below the beginning point of water penetration in order to avoid unwanted penetration during severe storm conditions.

Beginning Point of Water Penetration = 1,009 fpm

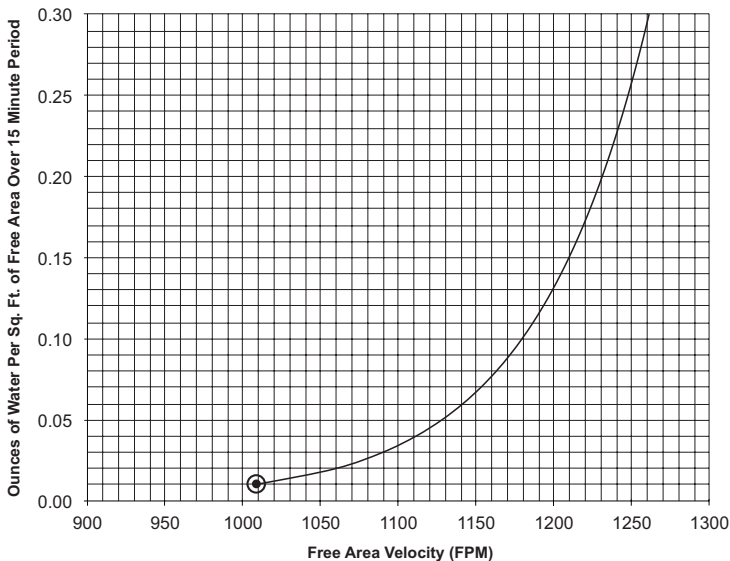

Certified Ratings:

All-Lite certifies that the model EFD-645 shown herein is licensed to bear the AMCA seal. The ratings shown are based on test and procedures performed in accordance with AMCA Publication 511 and comply with the requirements of the AMCA Certified Ratings Program. The AMCA Certified Ratings seal applies to air performance and water penetration ratings.

Pressure Loss

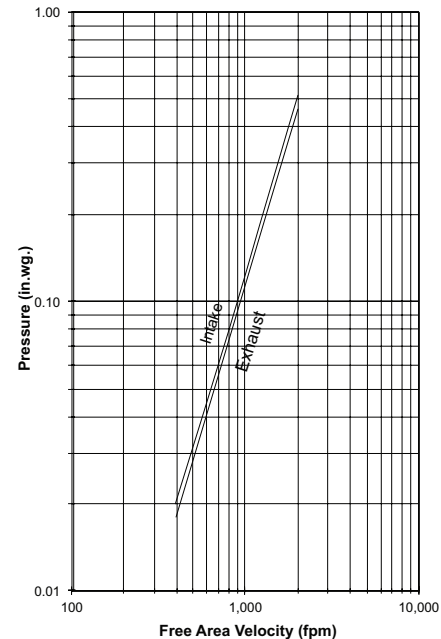

Louver Test Size = 48" x 48" (1219 x 1219)

EFD-645

Extruded Aluminum Louver
6" deep • 45° Drainable Blade

Attributes

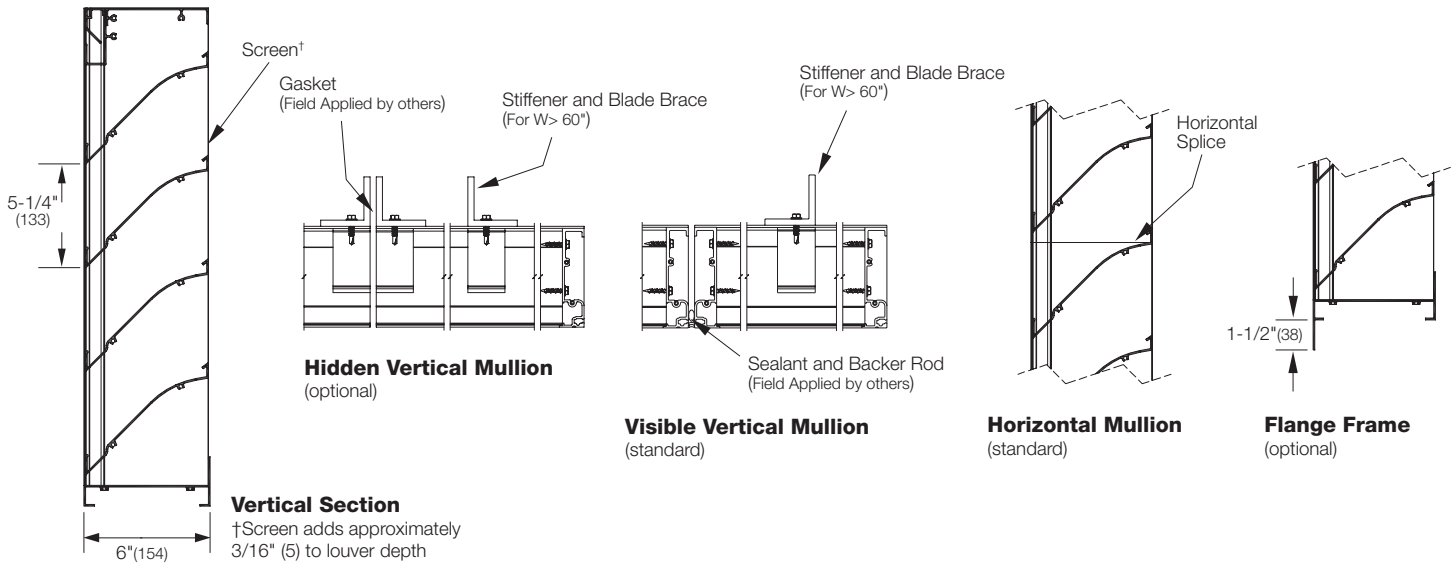

Supplemental Options

