

## Application

Model DFDAF-310 is a dynamic rated multi-blade fire damper with airfoil style blades for use in walls, floors, and partitions with fire resistance rating of less than 3 hours. This damper may be installed vertically (with blades running horizontal) or horizontally and is rated for airflow in either directions.

This model has a manual quadrant which allows the DFDAF-310 to function as both a fire damper and a manual balancing damper.

## Ratings

### UL 555 Fire Resistance Rating

Fire Rating: 1½ hours

Dynamic Closure Rating: Actual ratings are size dependent

Velocity: Up to 4000 fpm (20.3 m/s) on sizes up to 32 in. x 50 in. (813 mm x 1270 mm);  
 2000 fpm (10.2 m/s) on sizes greater than 32 in. x 50 in.  
 (813 mm x 1270 mm)

Pressure: Up to 8 in. wg (2 kPa)

## Construction

Construction	Standard	Optional
Frame Material	Galvanized steel	-
Frame Material Thickness	16 ga. (1.5 mm)	-
Frame Type	5 in. x 1 in. (127 mm x 25 mm) hat channel	-
Blade Action	Opposed	-
Blade Material	Galvanized steel	-
Blade Material Thickness	14 ga. (2 mm) equivalent	-
Blade Type	Double skin airfoil	-
Linkage	Plated steel out of airstream, concealed in jamb	316SS
Axle Bearings	316SS	-
Axle Material	Plated steel	316SS
Jamb Seals	Stainless Steel	-
Closure Device	Fusible link	-
Closure Temperature	165°F (74°C)	212°F (100°C), 286°F (141°C), 350°F (177°C)
Actuator	Manual quadrant	-



W & H dimensions furnished approximately ¼ in. (6 mm) undersize.  
 (Add sleeve thickness for overall sleeved damper dimension)



See complete marking on product.

UL 555 Classification R13317

CAN/ULC S112 Classified Fire Damper

Model DFDAF-310 meets the requirements for fire dampers established by:

### National Fire Protection Association

NFPA Standards 80, 90A & 101

### IBC International Building Codes

### CSFM California State Fire Marshal

Fire Damper Listing (#3225-0981:103)

## Size Limitations

W x H	Minimum Size	Maximum Size		
		Single Section	Multi-Section	
			2000 fpm (10.2 m/s)	4000 fpm (20.3 m/s)
Inches	8 x 6	32 x 50	128 x 100 (V) or 144 x 96 (H)	32 x 50
mm	203 x 152	813 x 1270	3251 x 2540 or 3658 x 2438	813 x 1270



# AMCA Pressure Drop

AMCA Figure 5.2

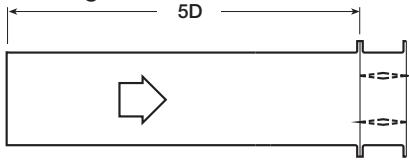

12 in. x 12 in. (305mm x 305mm)

Velocity (fpm)	Pressure Drop (in. wg)
500	0.03
1000	0.12
1500	0.26
2000	0.46
2500	0.72
3000	1.04
3500	1.41
4000	1.84

24 in. x 24 in. (610mm x 610mm)

Velocity (fpm)	Pressure Drop (in. wg)
500	0.01
1000	0.06
1500	0.12
2000	0.22
2500	0.34
3000	0.49
3500	0.67
4000	0.87

36 in. x 36 in. (914mm x 914mm)

Velocity (fpm)	Pressure Drop (in. wg)
500	0.01
1000	0.06
1500	0.12
2000	0.22
2500	0.34
3000	0.49
3500	0.67
4000	0.88

12 in. X 48 in. (305mm x 1219mm)

Velocity (fpm)	Pressure Drop (in. wg)
500	0.01
1000	0.05
1500	0.12
2000	0.21
2500	0.33
3000	0.48
3500	0.65
4000	0.88

48 in. x 12 in. (1219mm x 305mm)

Velocity (fpm)	Pressure Drop (in. wg)
500	0.02
1000	0.08
1500	0.18
2000	0.33
2500	0.51
3000	0.74
3500	1.00
4000	1.31

AMCA Figure 5.3

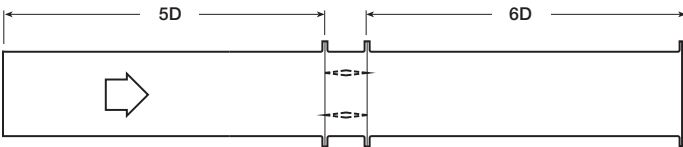

12 in. x 12 in. (305mm x 305mm)

Velocity (fpm)	Pressure Drop (in. wg)
500	0.01
1000	0.06
1500	0.13
2000	0.23
2500	0.37
3000	0.53
3500	0.73
4000	0.95

24 in. x 24 in. (610mm x 610mm)

Velocity (fpm)	Pressure Drop (in. wg)
500	0.01
1000	0.02
1500	0.06
2000	0.10
2500	0.16
3000	0.23
3500	0.32
4000	0.42

36 in. x 36 in. (914mm x 914mm)

Velocity (fpm)	Pressure Drop (in. wg)
500	0.01
1000	0.02
1500	0.05
2000	0.09
2500	0.14
3000	0.21
3500	0.29
4000	0.38

12 in. X 48 in. (305mm x 1219mm)

Velocity (fpm)	Pressure Drop (in. wg)
500	0.01
1000	0.02
1500	0.06
2000	0.10
2500	0.16
3000	0.24
3500	0.33
4000	0.43

48 in. x 12 in. (1219mm x 305mm)

Velocity (fpm)	Pressure Drop (in. wg)
500	0.01
1000	0.04
1500	0.10
2000	0.18
2500	0.29
3000	0.42
3500	0.57
4000	0.74

AMCA Figure 5.5

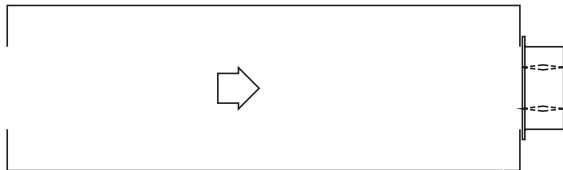

12 in. x 12 in. (305mm x 305mm)

Velocity (fpm)	Pressure Drop (in. wg)
500	0.04
1000	0.18
1500	0.42
2000	0.75
2500	1.17
3000	1.68
3500	2.29
4000	2.99

24 in. x 24 in. (610mm x 610mm)

Velocity (fpm)	Pressure Drop (in. wg)
500	0.03
1000	0.13
1500	0.29
2000	0.52
2500	0.81
3000	1.17
3500	1.60
4000	2.14

36 in. x 36 in. (914mm x 914mm)

Velocity (fpm)	Pressure Drop (in. wg)
500	0.03
1000	0.12
1500	0.27
2000	0.48
2500	0.75
3000	1.08
3500	1.48
4000	1.93

12 in. X 48 in. (305mm x 1219mm)

Velocity (fpm)	Pressure Drop (in. wg)
500	0.03
1000	0.12
1500	0.27
2000	0.49
2500	0.77
3000	1.11
3500	1.51
4000	1.97

48 in. x 12 in. (1219mm x 305mm)

Velocity (fpm)	Pressure Drop (in. wg)
500	0.03
1000	0.14
1500	0.32
2000	0.57
2500	0.89
3000	1.28
3500	1.75
4000	2.29



Greenheck Fan Corporation certifies that the model DFDAF-310 shown herein is licensed to bear the AMCA Seal. The ratings shown are based on tests and procedures performed in accordance with AMCA Publication 511 and comply with the requirements of the AMCA Certified Ratings Programs. The AMCA Certified Ratings Seal applies to air performance ratings only.

## Sleeve and Sideplate Dimensions

The drawings below and corresponding table show the position of the DFDAF-310 damper when mounted in a factory sleeve ("A" dimension). The standard mounting locations provide enough space for the mounting of manual quadrant(s) and allow space for installation of retaining angles and duct connections. The following options may affect the range of available mounting locations: transitions, security bars, grille tabs.

The standard location of a damper mounted in a factory sleeve ("A" dimension) is shown below. The damper can be positioned at other locations within a range of 7 3/16 in. (183 mm) to 16 in. (406 mm) for the "A" dimension.

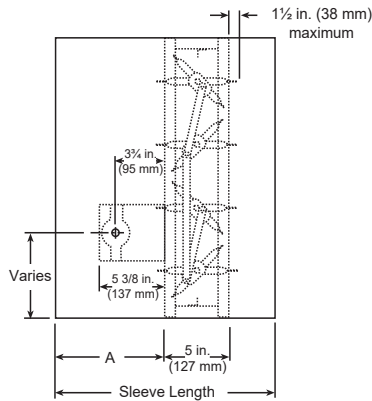

Sleeve

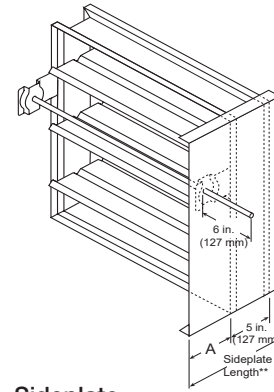

Sideplate

in. (mm)	With Sleeve		Sideplate Damper Location "A"
	Minimum Damper Location "A"	Maximum Damper Location "A"	
Dampers with no OCI	7 3/16 in. (183)	16 (406)	6 3/16 (157)
Height < 12 in. (305) OCI	12 (305)	16 (406)	12 (305)
Height ≥ 12 in. (305) OCI	7 3/16 in. (183)	16 (406)	12 (305)

**NOTE:** Entire damper frame is not required to be installed within the wall. The damper blades, when closed should be contained within the wall.

## Multiple Section Dampers

Dampers larger than maximum single section size are supplied as a factory assembly of two or more sections of equal size. The following figures show maximum damper section size and assembly configurations for multi-section dampers. Larger damper sizes may ship in multiple sections.

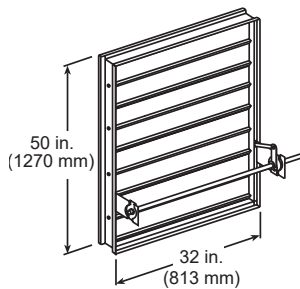

Single Section

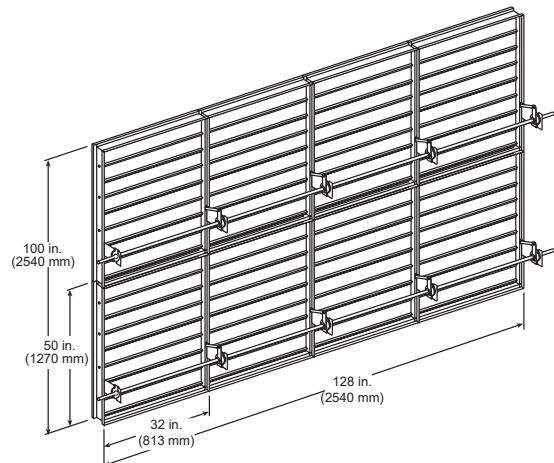

Multi-Section

Document Links

---



[INSTALLATION](#)



[CATALOG](#)



[INSTALLATION SOLUTIONS](#)



[SELECTION GUIDE](#)



[SPECIFICATIONS](#)



[WARRANTY](#)