

ECV-545

(standard)

*Louver dimensions furnished approximately 1/2" (13) undersize.

Ratings

Free Area: [48" × 48" (1219 × 1219) unit]: 8.77 ft² (0.82 m²)
54.8%

Performance @ Beginning Point of Water Penetration

Free Area Velocity: 1,250 fpm (6.35 m/s)

Air Volume Delivered: 10,963 cfm (5.17 m³/s)

Pressure Loss: 0.28 in.wg. (70 Pa)

Velocity @ 0.15 in.wg. Pressure Loss: 912 fpm (4.63 m/s)

AMCA 540 (impact resistant, Enhanced protection) listed

AMCA 550 (high velocity rain resistant) listed

Design Load: 130 psf

The ECV-545 is engineered and tested to withstand extreme loads, debris impact, and cyclic fatigue associated with the severe weather effects of hurricanes while maintaining maximum water infiltration resistance at a minimum louver depth. For installation, the ECV-545 offers a continuous angle option. The ECV-545 is AMCA 540 and 550 listed, making it ideally suited for use in hurricane-prone and wind-borne debris regions as per the International Building Code.

Standard Construction

Material: Mill finish 6063-T6 extruded aluminum

Frame: 5" deep × 0.081" thick (127 × 2) channel

Blades: 45° × 0.06" (1.5) thick vertical chevron style.
Right-facing blade orientation

Screen: 1/2" × 0.063" (12.7 × 1.6) expanded and flattened aluminum

Mullion: Visible

Minimum Size: 12" × 12" (305 × 305)

Maximum Size:

Single section: 60" × 120" (1524 × 3048)
Multiple section: Unlimited

Shipping Weight (approximate): 5.5 lbs/ft² (48 kg/m²)

Options

■ Factory finish:

- High Performance Fluoropolymer
- Prime Coat
- Baked Enamel
- Clear Anodize
- Integral Color Anodize

■ Frame Options:

- 1-1/2" (38) flange frame

■ Installation Hardware

- Continuous angles

■ Alternate bird or insect screens

■ Insulated or non-insulated blank-off panels

■ Filter racks

■ Head and/or sill flashing

■ Burglar bars

■ Left-facing blade orientation

5 year
warranty

NOTE: Dimensions in parentheses () are millimeters.
Information is subject to change without notice or obligation.

PERFORMANCE

ECV-545

Extruded Aluminum Louver
5" deep • Vertical Blade

Free Area (ft²)

		Width (Inches)								
		12	18	24	30	36	42	48	54	60
Height (Inches)	12	0.3	0.4	0.6	0.8	1.0	1.2	1.3	1.5	1.7
	18	0.5	0.8	1.2	1.5	1.9	2.2	2.6	2.9	3.3
	24	0.7	1.2	1.8	2.3	2.8	3.3	3.8	4.3	4.8
	30	1.0	1.6	2.3	3.0	3.7	4.4	5.1	5.7	6.4
	36	1.2	2.1	2.9	3.7	4.6	5.4	6.3	7.1	8.0
	42	1.4	2.5	3.5	4.5	5.5	6.5	7.5	8.5	9.6
	48	1.7	2.9	4.0	5.2	6.4	7.6	8.8	9.9	11.1
	54	1.9	3.3	4.6	6.0	7.3	8.7	10.0	11.4	12.7
	60	2.2	3.7	5.2	6.7	8.2	9.7	11.2	12.8	14.3
	66	2.4	4.1	5.8	7.4	9.1	10.8	12.5	14.2	15.8
	72	2.6	4.5	6.3	8.2	10.0	11.9	13.7	15.6	17.4
	78	2.9	4.9	6.9	8.9	10.9	12.9	15.0	17.0	19.0
	84	3.1	5.3	7.5	9.6	11.8	14.0	16.2	18.4	20.6
90	3.3	5.7	8.0	10.4	12.7	15.1	17.4	19.8	22.1	
96	3.6	6.1	8.6	11.1	13.6	16.1	18.7	21.2	23.7	
102	3.8	6.5	9.2	11.9	14.5	17.2	19.9	22.6	25.3	
108	4.0	6.9	9.7	12.6	15.4	18.3	21.1	24.0	26.8	
114	4.3	7.3	10.3	13.3	16.3	19.4	22.4	25.4	28.4	
120	4.5	7.7	10.9	14.1	17.2	20.4	23.6	26.8	30.0	



Certified Ratings:

Pottorff certifies that the model ECV-545 shown herein is licensed to bear the AMCA seal. The ratings shown are based on test and procedures performed in accordance with AMCA Publication 511 and comply with the requirements of the AMCA Certified Ratings Program. The AMCA Certified Ratings seal applies to air performance, water penetration and wind-driven rain ratings.



HIGH VELOCITY RAIN RESISTANT AND IMPACT RESISTANT LOUVER *Enhanced Protection*

See www.AMCA.org for all certified or listed products

This label does not signify
AMCA airflow performance
certification.

Certified Ratings:

Pottorff certifies that the model ECV-545 shown herein is approved to bear the AMCA listing label. The ratings shown are based on tests and procedures performed in accordance with AMCA publications and comply with the requirements of the AMCA listing label program. The AMCA listing label applies to high velocity rain and wind borne debris impact resistant louvers.

Water Penetration

AMCA defines the beginning point of water penetration as the free area velocity at the intersection of a simple linear regression of test data and the line of 0.01 ounces of water per square foot of free area measured through a 48" x 48" louver during a 15 minute period. The AMCA water penetration test provides a method for comparing louver models and designs as to their efficiency in resisting the penetration of rainfall under specific lab conditions. We recommend that intake louvers are selected with a reasonable margin of safety below the beginning point of water penetration in order to avoid unwanted penetration during severe storm conditions.

Beginning Point of Water Penetration = 1,250 fpm

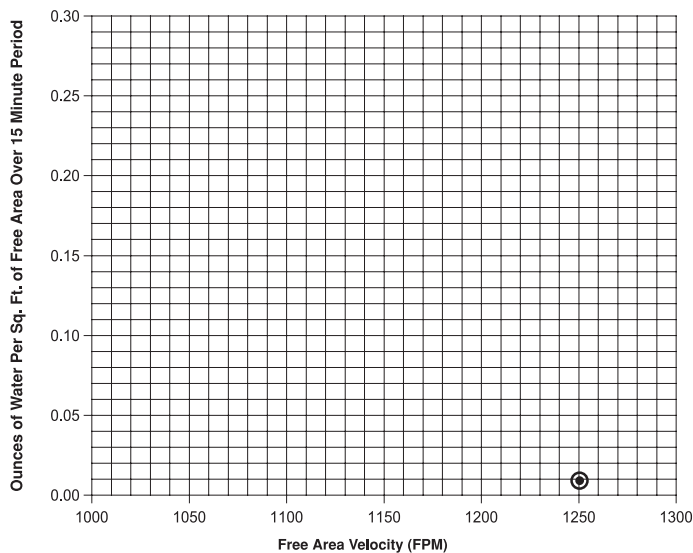

Pressure Loss

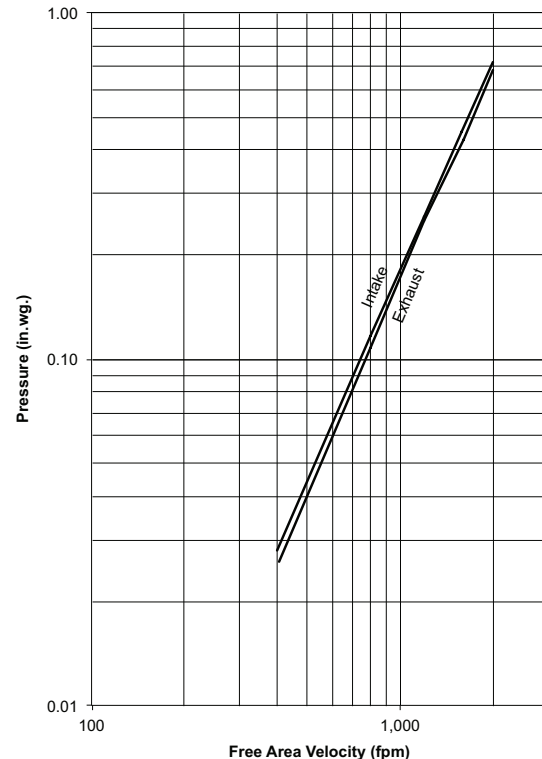

Louver Test Size = 48" x 48" (1219 x 1219)

Pressure loss tested in accordance with Figure 5.5 of AMCA Standard 500-L. Data corrected to standard air density.

PERFORMANCE

ECV-545

Extruded Aluminum Louver
5" deep • Vertical Blade

Wind Driven Rain Performance - AMCA 500L Wind-Driven Rain Test

Wind Velocity	Rainfall	Airflow cfm (m ³ /s)	Core Velocity ¹ fpm (m/s)	Free Area Velocity ² fpm (m/s)	Effectiveness Ratio	Wind-Driven Rain Penetration Class
29 mph	3 in/hr	10,601 (5.0)	985 (5.0)	1,631 (8.3)	100%	A
50 mph	8 in/hr	10,605 (5.0)	985 (5.0)	1,632 (8.3)	99.7%	A

NOTE:

1. Core area is the open area of the louver face (face area less louver frame). Core velocity is the airflow divided by core area. Test louver core area is 10.77 ft² (1 m²).

2. Free area velocity is the airflow divided by free area. Test louver free area is 6.5 ft² (0.6 m²).

Wind Driven Rain

Class	Effectiveness
A	99% and above
B	95% to 98.9%
C	80% to 94.9%
D	below 80%

Attributes

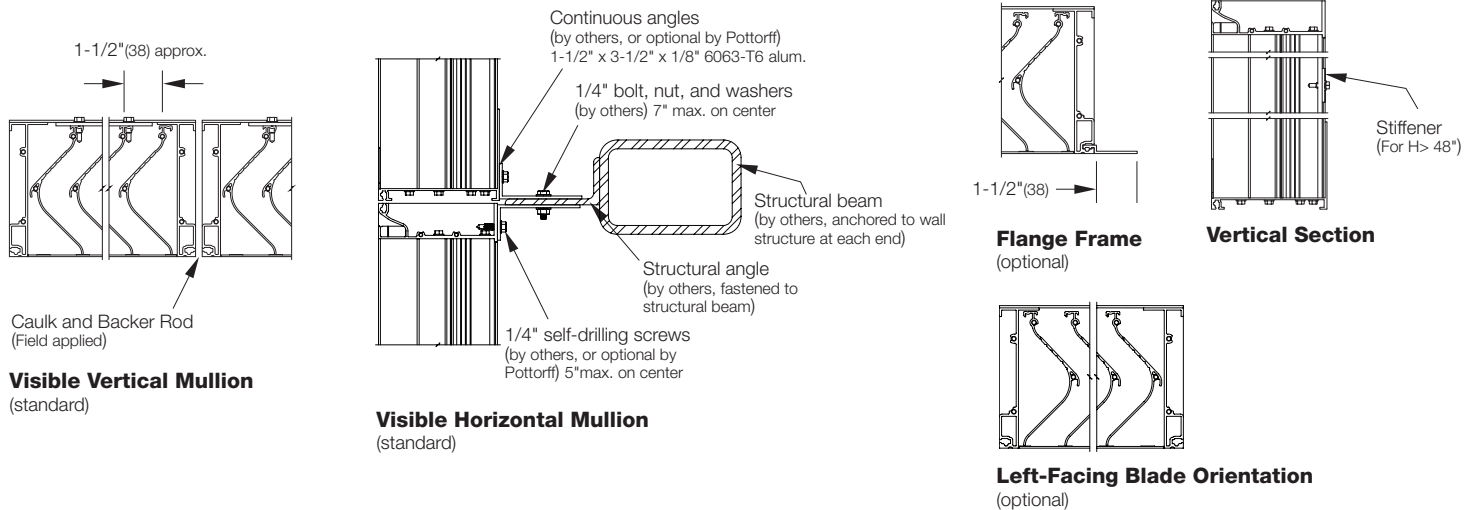

Supplemental Options

