

Centrifugal Upblast & Sidewall Exhaust Models CUE, CUBE and USGF Performance Data



 **VARI-GREEN** performance data included



BUILDING VALUE IN AIR.

November
2024

Model Comparison																										
Model	Location		Mounting					Airflow				Application						Drive Type		Impeller Type			Performance			
	Outdoor	Indoor	Roof Curb	Base/Floor	Hanging	Wall	Ceiling Mounted	Exhaust	Supply	Reversible	Recirculate	General/Clean Air	Contaminated Air	Spark Resistant	Grease (UL 705 Supplement SC)	Smoke Control (UL 705 Supplement SD)	High Wind (150 mph)	High Temp (above 200°F)	Seismic Certification	Belt	Direct	Centrifugal	Propeller/Axial	Mixed Flow	Maximum Volume (cfm)	Maximum Static Pressure (in. wg)
CUE	✓		✓			✓		✓				✓	✓	✓	✓		✓	✓		✓	✓				14,700	3
CUBE	✓		✓			✓		✓				✓	✓	✓	✓	✓	✓	✓		✓		✓			30,000	5
USGF	✓		✓					✓				✓	✓	✓			✓			✓		✓			6,800	3.25

Adjusting curb cap sizes in CAPS® eliminates the need for ordering an adapter. This is available for both roof or sidewall mounted. Here is a chart of available curb cap sizes that are selectable in CAPS.

		Curb Cap Sizes																									
		17	18	19	20	21	22	23	24	25	26	27	28	29	30	31	32	33	34	35	36	37	38	39	40		
Model Size	60	std.																									
	70	std.																									
	80			std.																							
	90			std.																							
	95			std.																							
	99			std.			✓																				
	100*			std.			✓																				
	120			std.			✓																				
	130			std.			✓																				
	140*						std.				✓																
	160*						std.				✓																
	180*																										std.
	200*																										std.
	220*																										std.
	240*																										std.

* Includes HP and XP



- UL/cUL705 Listed Power Ventilators
File E40001 (CUE and CUBE)
- UL/cUL 705 Supplement SC Power Ventilators for Restaurant Exhaust Appliances
File MH11745 (CUE, CUBE and USGF sizes 099 and larger)
- UL/cUL Power Ventilators for Smoke Control Systems
File MH17511 (CUBE and USGF models 500°F (260°C) for 4 hours and 1,000°F (538°C) for 15 minutes)

Note: UL/cUL is optional and must be specified

Model sizes CUBE-099, 160XP, 240XP, 300HP & 300XP are excluded from Power Ventilators for Smoke Control Systems



Models CUE, CUBE, and USGF meet CE (Conformité Européenne).



Greenheck Fan Corporation certifies that the Model CUE, CUBE, and USGF shown herein are licensed to bear the AMCA Seal. The ratings shown are based on tests and procedures performed in accordance with AMCA Publication 211 and Publication 311 and comply with the requirements of the AMCA Certified Ratings Program. The certified ratings for Model CUBE, CUE and USGF, are shown on pages 4-35.



Dimension Quick Reference						Material Thickness		
Model Size	CUE / CUBE					Windband	Motor Cover	Curb Cap
	Standard Curb Cap	Damper	Roof / Wall Opening	Wall Opening with a curb	Approximate Weight **			
060 •	17	8	13 1/2	17	29	0.051	0.051	0.051
070 •	(432)	(203)	(343)	(432)	(13)	(1.3)	(1.3)	(1.3)
080 •								
090 •	19	10	15 1/2	19	40	0.051	0.051	0.064
095 •	(483)	(254)	(393)	(483)	(18)	(1.3)	(1.3)	(1.6)
099 •								
100 •								
100HP •	19	12	15 1/2	19	67			
120 •	(483)	(305)	(393)	(483)	(30)			
130 •						0.051	0.040	0.064
140 •						(1.3)	(1.0)	(1.6)
140HP •								
160 •	22	16	18 1/2	22	90			
160HP •	(559)	(406)	(470)	(559)	(41)			
160XP •								
180 •					126			
180HP •	30	24	26 1/2	30	(57)			
200 •	(762)	(610)	(673)	(762)	142	0.064	0.040	0.064
200HP •					(64)	(1.6)	(1.0)	(1.6)
220 •								
220HP •								
240 •	34	24	30 1/2	34	175	0.064	0.051	0.064
240HP •	(864)	(610)	(775)	(864)	(79)	(1.6)	(1.3)	(1.6)
240XP •								
300 •								
300HP •	40	34	36 1/2	40	313	0.080	0.051	0.064
300XP •	(1016)	(864)	(927)	(1016)	(142)	(2.0)	(1.3)	(1.6)
360* •								
360HP* •	46	40	42 1/2	N/A	440	0.080	0.064	0.080
360XP* •	(1168)	(1016)	(1080)		(200)	(2.0)	(1.6)	(2.0)
420* •	52	46	48 1/2	N/A	578	0.080	0.064	0.100
	(1321)	(1168)	(1232)		(262)	(2.0)	(1.6)	(2.5)
480* •	58	52	54 1/2	N/A	675			
	(1473)	(1321)	(1384)		(306)			

USGF					Windband	Motor Cover	Curb Cap
Model Size	Standard Curb Cap	Damper	Roof / Wall Opening	Wall Opening with a curb			
140							
140HP							
160	26	N/A	18 1/2	N/A	125	0.051	0.040
160HP	(660)		(470)		(57)	(1.3)	(1.0)
160XP					131		0.064
					(59)		(1.6)
180					190		
180HP	30	N/A	20 1/2	N/A	(86)		
200	(762)		(521)		213		
200HP					(97)		

The Model number system is designed to completely identify the fan. The correct code letters must be specified to designate belt or direct drive. The remainder of the model number is determined by the size and performance.

CUBE-240HP-A-5-VG/VGD-1-34-X

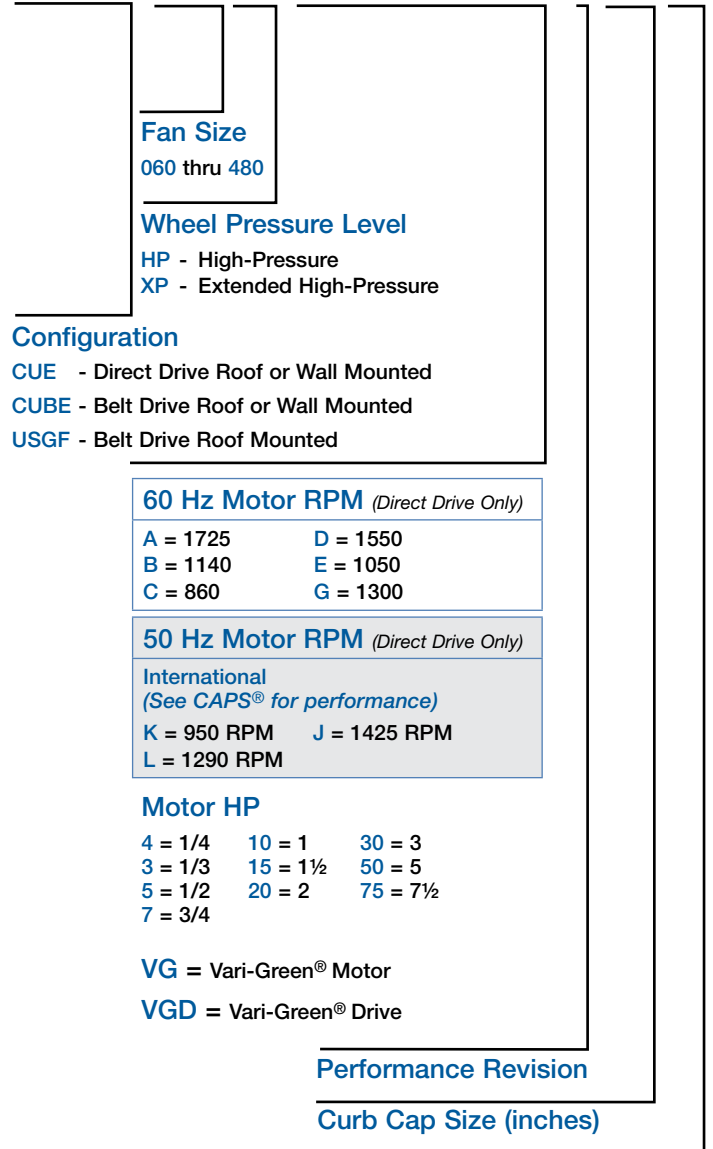

All dimensions are in inches (millimeters)

● Vari-Green option available

* CUBE only

** Approximate weight shown in lbs. (kg) is the largest cataloged open drip proof motor

Roof Upblast/Sidewall Exhaust Size-060: CUE

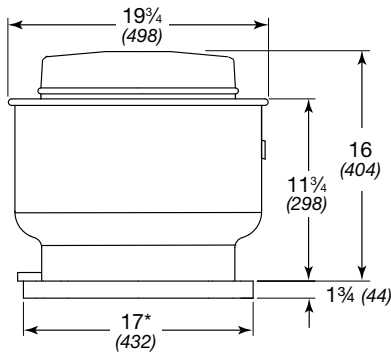

Direct Drive RPM

E-1050 RPM
G-1300 RPM
D-1550 RPM
VG-1725 RPM

All dimensions in inches (millimeters), weight in pounds (kilograms).
^Weight shown is largest cataloged open drip-proof motor.

With Standard Curb Cap*

	CUE
^Approximate Weight	29 (13)
Damper Size	8 x 8 (203 x 203)
Roof/Wall (without wall bracket) Opening	13 1/2 x 13 1/2 (343 x 343)
Wall Opening with Wall Bracket	13 x 13 (330 x 330)
Wall Opening with Curb Through Wall	17 x 17 (432 x 432)

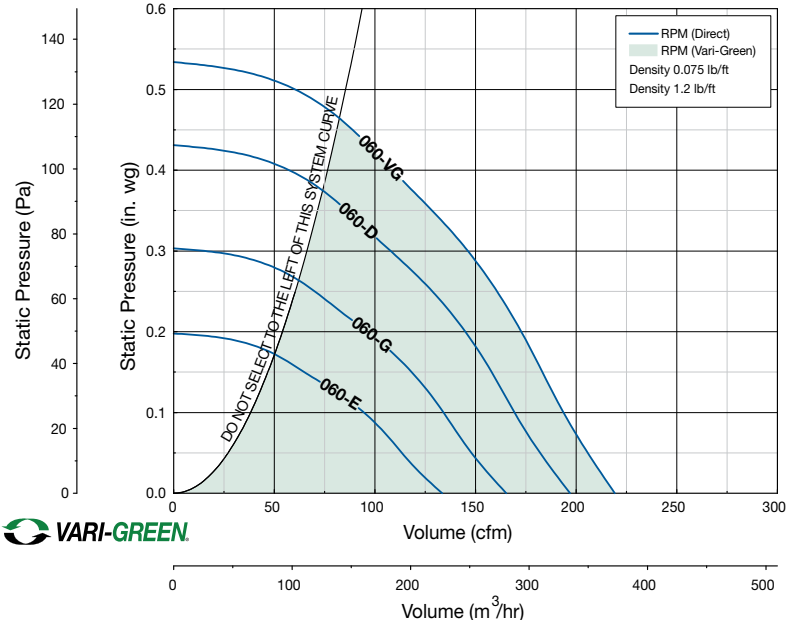

Motor HP	Fan RPM	Static Pressure in Inches wg											
			0	0.05	0.1	0.125	0.15	0.2	0.25	0.3	0.35	0.375	
060													
VARI-GREEN	E-1/200	1050	CFM	133	113	94	81	65					
		BHP	0.01	0.01	0.01	0.01	0.01						
		Sones	1.7	1.7	1.7	1.7	1.7						
	G-1/100	1300	CFM	165	148	134	126	117	96	70			
		BHP	0.01	0.01	0.01	0.01	0.01	0.01	0.01	0.01			
		Sones	2.9	2.6	2.5	2.5	2.5	2.5	2.5	2.5			
	D-1/60	1550	CFM	197	183	169	164	158	143	128	107	85	
		BHP	0.02	0.02	0.02	0.02	0.02	0.02	0.02	0.02	0.02	0.02	
		Sones	4.3	3.9	3.9	3.9	3.9	4.0	4.0	4.0	4.0	4.0	
		1725	CFM	219	207	194	188	183	172	159	146	137	118
		BHP	0.028	0.028	0.028	0.028	0.028	0.028	0.028	0.028	0.029	0.029	0.029
		Sones	5.4	5	5.1	5.2	5.2	5.2	5.2	5.3	5.3	5.4	5.5

Performance certified is for installation type A: Free inlet, Free outlet. Power rating (BHP) does not include transmission losses. Performance ratings do not include the effects of appurtenances (accessories). The sound ratings shown are loudness values in fan sones at 5 ft. (1.5 m) in a hemispherical free field calculated per AMCA Standard 301. Values shown are for installation type A: Free inlet hemispherical sone levels.

Roof Upblast/Sidewall Exhaust Size-070: CUE

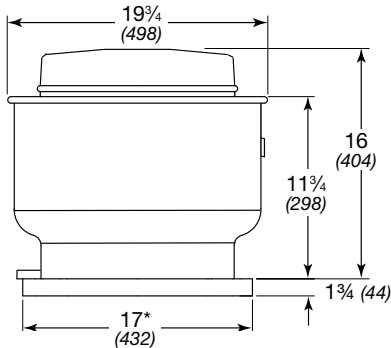

Direct Drive RPM

E-1050 RPM
G-1300 RPM
D-1550 RPM
VG-1725 RPM

All dimensions in inches (millimeters), weight in pounds (kilograms).

^Weight shown is largest cataloged open drip-proof motor.

With Standard Curb Cap*	CUE
^Approximate Weight	29 (13)
Damper Size	8 x 8 (203 x 203)
Roof/Wall (without wall bracket) Opening	13½ x 13½ (343 x 343)
Wall Opening with Wall Bracket	13 x 13 (330 x 330)
Wall Opening with a Curb Through Wall	17 x 17 (432 x 432)

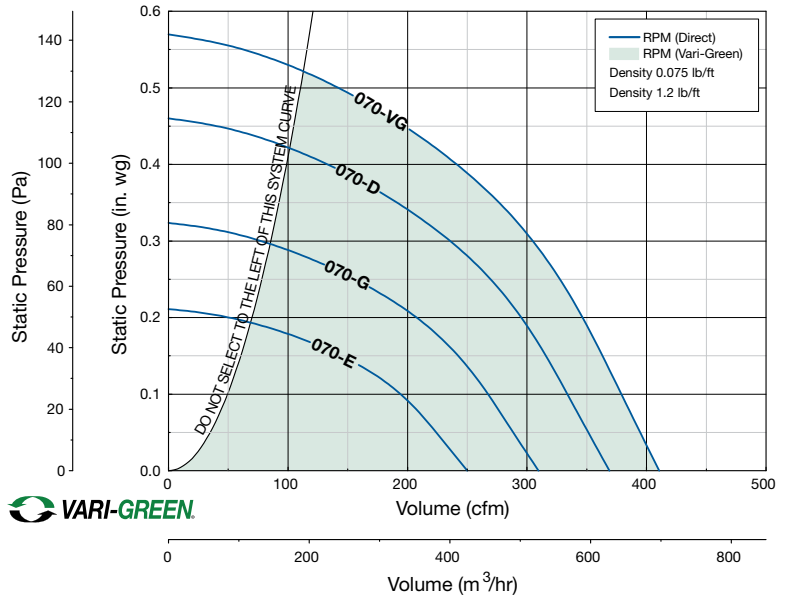

Motor HP	Fan RPM	Static Pressure in Inches wg												
		0	0.05	0.1	0.125	0.15	0.2	0.25	0.3	0.35	0.375			
070														
VARI-GREEN	E-1/100	1050	CFM	250	224	193	171	143						
			BHP	0.01	0.01	0.01	0.01	0.01						
			Sones	2.7	2.1	1.7	1.4	1.1						
	G-1/60	1300	CFM	309	288	267	255	241	205	152				
			BHP	0.01	0.01	0.02	0.02	0.02	0.02	0.01				
			Sones	4.1	3.8	3.4	3.3	3.2	2.8	2.5				
	D-1/30	1550	CFM	369	351	333	325	316	293	269	234	187	160	
			BHP	0.02	0.02	0.03	0.03	0.03	0.03	0.03	0.03	0.02	0.02	
			Sones	5.6	5.4	5.2	5.2	5.1	4.9	4.7	4.5	4.1	3.9	
		1725	CFM	411	395	379	371	363	346	326	305	289	258	
			BHP	0.032	0.032	0.033	0.034	0.035	0.036	0.036	0.036	0.036	0.035	0.035
			Sones	6.8	6.7	6.7	6.6	6.6	6.5	6.4	6.2	6.1	5.9	

Performance certified is for installation type A: Free inlet, Free outlet. Power rating (BHP) does not include transmission losses. Performance ratings do not include the effects of appurtenances (accessories). The sound ratings shown are loudness values in fan sones at 5 ft. (1.5 m) in a hemispherical free field calculated per AMCA Standard 301. Values shown are for installation type A: Free inlet hemispherical sone levels.

Roof Upblast/Sidewall Exhaust Size-080: CUE

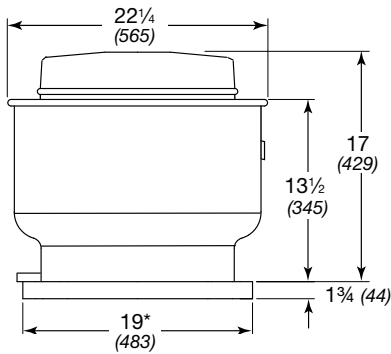

Direct Drive RPM

E-1050 RPM
G-1300 RPM
D-1550 RPM
VG-1725 RPM

All dimensions in inches (millimeters), weight in pounds (kilograms).
^Weight shown is largest cataloged open drip-proof motor.

With Standard Curb Cap*	CUE
^Approximate Weight	40 (18)
Damper Size	10 x 10 (254 x 254)
Roof/Wall (without wall bracket) Opening	15½ x 15½ (394 x 394)
Wall Opening with Wall Bracket	15 x 15 (381 x 381)
Wall Opening with a Curb Through Wall	19 x 19 (483 x 483)

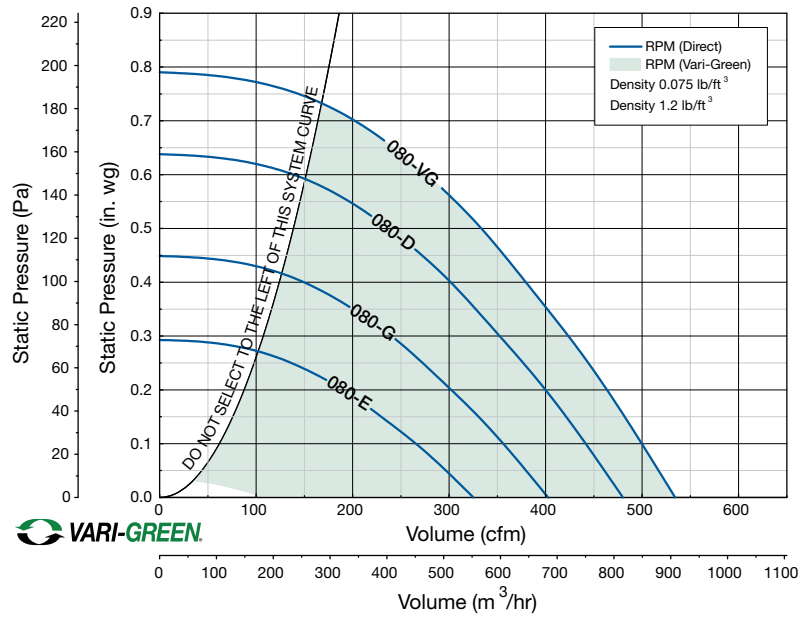

Motor HP	Fan RPM	Static Pressure in Inches wg											
		0	0.1	0.125	0.15	0.2	0.25	0.3	0.375	0.5	0.625		
080													
VARI-GREEN VG-1/10	E-1/40	1050	CFM	325	265	247	230	189	133				
			BHP	0.01	0.01	0.02	0.02	0.02	0.02	0.02			
			Sones	3.8	3.7	3.6	3.7	3.9	4.2				
	G-1/30	1300	CFM	403	356	343	330	302	272	239	173		
			BHP	0.02	0.03	0.03	0.03	0.03	0.03	0.03	0.03	0.03	
			Sones	5.4	5.4	5.4	5.4	5.4	5.5	5.6	5.9		
	D-1/20	1550	CFM	480	441	431	421	400	376	352	314	235	
			BHP	0.04	0.04	0.04	0.04	0.05	0.05	0.05	0.05	0.05	0.05
			Sones	7.3	7.3	7.3	7.3	7.3	7.2	7.2	7.3	7.5	
		1725	CFM	534	500	491	481	463	444	423	390	333	257
			BHP	0.05	0.06	0.06	0.06	0.06	0.06	0.07	0.07	0.07	0.07
			Sones	8.4	8.5	8.5	8.5	8.6	8.6	8.6	8.6	8.5	8.7

Performance certified is for installation type A: Free inlet, Free outlet. Power rating (BHP) does not include transmission losses. Performance ratings do not include the effects of appurtenances (accessories). The sound ratings shown are loudness values in fan sones at 5 ft. (1.5 m) in a hemispherical free field calculated per AMCA Standard 301. Values shown are for installation type A: Free inlet hemispherical sone levels.

Roof Upblast/Sidewall Exhaust Size-090: CUE

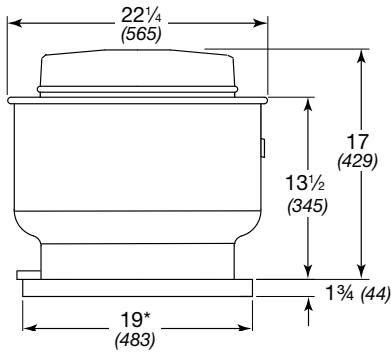

Direct Drive RPM

E-1050 RPM
G-1300 RPM
D-1550 RPM
VG-1725 RPM

All dimensions in inches (millimeters), weight in pounds (kilograms).
^Weight shown is largest cataloged open drip-proof motor.

With Standard Curb Cap*	CUE
^Approximate Weight	40 (18)
Damper Size	10 x 10 (254 x 254)
Roof/Wall (without wall bracket) Opening	15½ x 15½ (394 x 394)
Wall Opening with Wall Bracket	15 x 15 (381 x 381)
Wall Opening with a Curb Through Wall	19 x 19 (483 x 483)

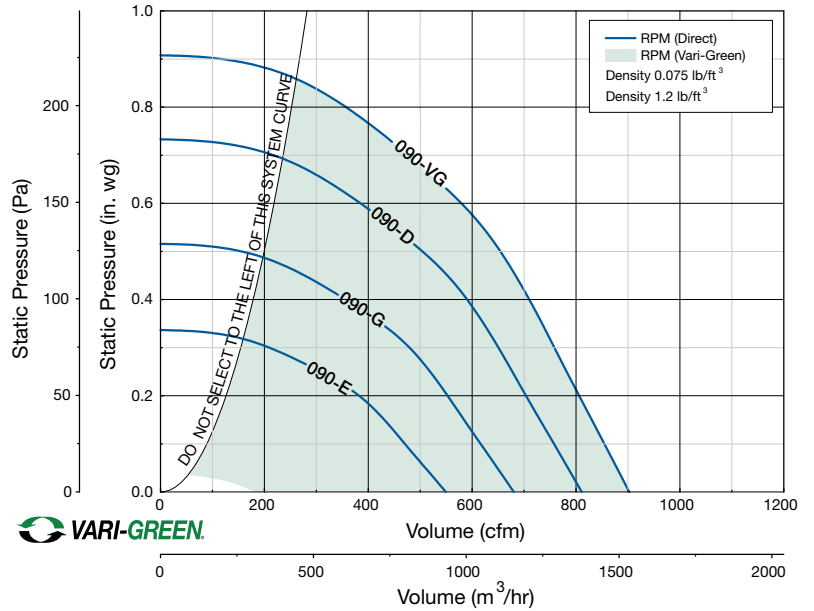

Motor HP	Fan RPM	Static Pressure in Inches wg	Static Pressure in Inches wg																			
			0	0.1	0.125	0.15	0.2	0.25	0.3	0.375	0.5	0.625										
090																						
VARI-GREEN VG-1/10	E-1/40	1050	CFM	549	470	451	429	381	306	204												
			BHP	0.02	0.02	0.02	0.03	0.03	0.03	0.03	0.03											
	Sones	4.0	3.9	3.9	4.0	4.1	4.2	4.5														
	G-1/30	1300	CFM	680	616	600	584	553	517	479	391											
			BHP	0.04	0.04	0.04	0.04	0.05	0.05	0.05	0.05	0.05										
	Sones	5.4	5.4	5.4	5.4	5.4	5.5	5.5	5.5	5.6												
	D-1/20	1550	CFM	811	757	744	731	704	677	651	604	501	347									
			BHP	0.06	0.07	0.07	0.07	0.07	0.08	0.08	0.08	0.08	0.09	0.08								
	Sones	7.6	7.5	7.5	7.5	7.5	7.5	7.5	7.5	7.4	7.4	7.4	7.9									
			1725	CFM	903	854	842	830	806	782	758	722	652	553								
				BHP	0.08	0.09	0.09	0.09	0.1	0.1	0.1	0.11	0.12	0.12								
	Sones	8.8	8.8	8.8	8.8	8.8	8.8	8.8	8.7	8.7	8.7	8.8	8.9									

Performance certified is for installation type A: Free inlet, Free outlet. Power rating (BHP) does not include transmission losses. Performance ratings do not include the effects of appurtenances (accessories). The sound ratings shown are loudness values in fan sones at 5 ft. (1.5 m) in a hemispherical free field calculated per AMCA Standard 301. Values shown are for installation type A: Free inlet hemispherical sone levels.

Roof Upblast/Sidewall Exhaust Size-095: CUE

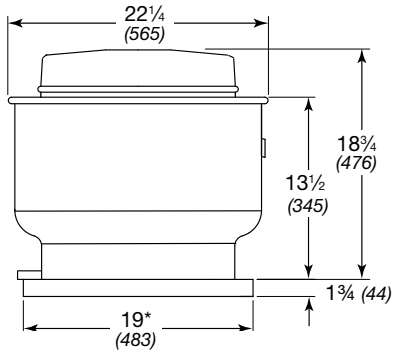

Direct Drive RPM

E-1050 RPM
G-1300 RPM
D-1550 RPM
VG-1725 RPM

All dimensions in inches (millimeters), weight in pounds (kilograms).
 ^Weight shown is largest cataloged open drip-proof motor.

With Standard Curb Cap*	CUE
^Approximate Weight	40 (18)
Damper Size	10 x 10 (254 x 254)
Roof/Wall (without wall bracket) Opening	15 1/2 x 15 1/2 (394 x 394)
Wall Opening with Wall Bracket	15 x 15 (381 x 381)
Wall Opening with a Curb Through Wall	19 x 19 (483 x 483)

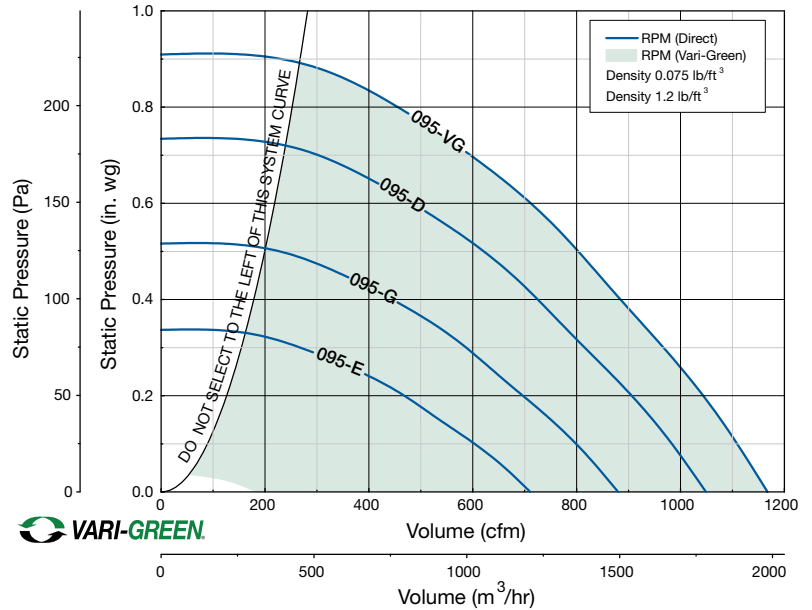

Motor HP	Fan RPM	Static Pressure in Inches wg											
		0	0.1	0.125	0.15	0.2	0.25	0.3	0.375	0.5	0.625		
095													
VARI-GREEN VG-1/6	E-1/30	1050	CFM	711	603	570	536	468	381	265			
		BHP	0.03	0.04	0.04	0.04	0.04	0.04	0.03				
		Sones	5.4	4.5	4.5	4.5	4.4	4.5	4.6				
	G-1/12	1300	CFM	880	797	774	750	696	641	587	484	199	
		BHP	0.06	0.07	0.07	0.07	0.07	0.07	0.07	0.07	0.07	0.05	
		Sones	7.6	6.9	6.7	6.6	6.5	6.4	6.4	6.4	6.4	6.8	
	D-1/8	1550	CFM	1049	983	964	944	905	861	816	747	616	442
		BHP	0.1	0.11	0.11	0.11	0.11	0.12	0.12	0.12	0.12	0.12	0.11
		Sones	9.6	9.4	9.3	9.2	8.9	8.6	8.4	8.3	8.3	8.1	7.8
		1725	CFM	1167	1108	1093	1077	1041	1005	967	905	802	680
		BHP	0.14	0.15	0.15	0.15	0.16	0.16	0.16	0.17	0.17	0.17	0.17
		Sones	11.3	11.1	11.0	11.0	10.8	10.5	10.2	9.9	9.8	9.8	9.6

Performance certified is for installation type A: Free inlet, Free outlet. Power rating (BHP) does not include transmission losses. Performance ratings do not include the effects of appurtenances (accessories). The sound ratings shown are loudness values in fan sones at 5 ft. (1.5 m) in a hemispherical free field calculated per AMCA Standard 301. Values shown are for installation type A: Free inlet hemispherical sone levels.

Roof Upblast/Sidewall Exhaust Size-099: CUBE • CUE

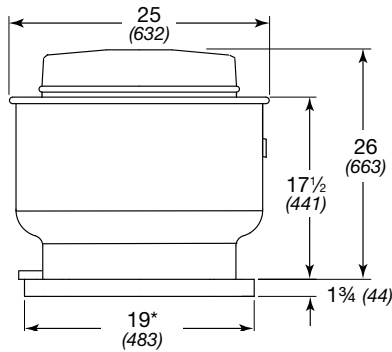

Direct Drive RPM

- C-860 RPM
- B-1140 RPM
- A-1725 RPM
- VG-1725 RPM

All dimensions in inches (millimeters), weight in pounds (kilograms).
^Weight shown is largest cataloged open drip-proof motor.

With Standard Curb Cap*	CUBE	CUE
^Approximate Weight	66 (30)	64 (29)
Damper Size	12 x 12 (305 x 305)	
Roof/Wall (without wall bracket) Opening	15½ x 15½ (394 x 394)	
Wall Opening with Wall Bracket	15 x 15 (381 x 381)	
Wall Opening with a Curb Through Wall	19 x 19 (483 x 483)	

* Additional curb cap sizes available, see page 2

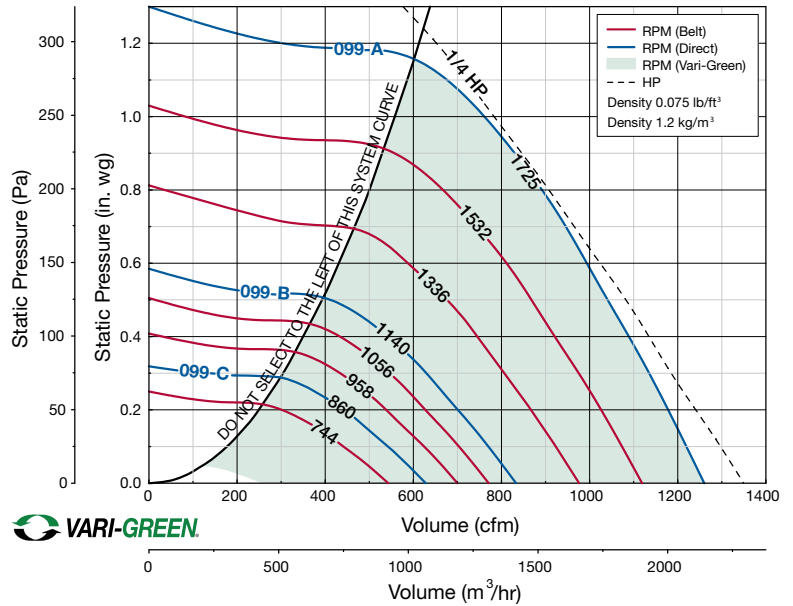

Motor HP		Fan RPM	Static Pressure in Inches wg																							
Belt	Direct		0	0.125	0.25	0.375	0.5	0.625	0.75	0.875	1	1.125														
099																										
1/4	VARI-GREEN	C-1/8	744	CFM	543	414																				
			BHP	0.02	0.02																					
		Sones	4.5	4.0																						
		860	CFM	628	518	376																				
			BHP	0.03	0.03	0.03																				
		Sones	5.3	4.7	4.3																					
		958	CFM	700	603	490																				
			BHP	0.04	0.04	0.04																				
		Sones	6.1	5.4	4.9																					
		1056	CFM	771	685	588	464																			
			BHP	0.05	0.06	0.06	0.06																			
		Sones	7.1	6.2	5.7	5.3																				
		B-1/6	1140	CFM	833	754	665	565	408																	
				BHP	0.06	0.07	0.07	0.07	0.07																	
		Sones	7.8	7.0	6.3	5.9	5.5																			
		1238	CFM	904	832	752	668	559																		
			BHP	0.08	0.09	0.09	0.09	0.09																		
		Sones	8.8	8.1	7.2	6.7	6.4																			
		1336	CFM	976	909	837	760	674	564																	
			BHP	0.10	0.11	0.11	0.12	0.12	0.11																	
		Sones	9.9	9.4	8.5	7.6	7.3	6.9																		
		1434	CFM	1047	986	920	848	776	687	567																
			BHP	0.13	0.13	0.14	0.14	0.14	0.14	0.14																
		Sones	10.8	10.4	9.7	8.8	8.3	8.0	7.6																	
1532	CFM	1119	1062	1001	935	868	794	705	583																	
	BHP	0.15	0.16	0.17	0.17	0.18	0.18	0.17	0.16																	
Sones	11.9	11.4	10.9	10.0	9.4	9.1	8.8	8.4																		
1630	CFM	1191	1137	1080	1020	956	893	818	730	609																
	BHP	0.19	0.19	0.20	0.21	0.21	0.21	0.21	0.21	0.20																
Sones	13.0	12.6	12.1	11.4	10.8	10.4	10.1	9.8	9.4																	
A-1/4	1725	CFM	1260	1209	1156	1100	1041	981	918	846	759	639														
		BHP	0.22	0.23	0.23	0.24	0.25	0.25	0.25	0.25	0.25	0.24	0.23													
Sones	14.2	13.8	13.4	12.9	12.3	11.7	11.5	11.2	10.8	10.6																

MAXIMUM BHP AT A
GIVEN RPM = $(RPM/3099)^3$
MAXIMUM RPM = 1725
TIP SPEED (ft/min) = $RPM \times 2.846$
MAXIMUM MOTOR FRAME SIZE = 56
AVERAGE DISCHARGE VELOCITY
(FPM) = $CFM/1.28$

Performance certified is for installation type A: Free inlet, Free outlet. Power rating (BHP) does not include transmission losses. Performance ratings do not include the effects of appurtenances (accessories). The sound ratings shown are loudness values in fan sones at 5 ft. (1.5 m) in a hemispherical free field calculated per AMCA Standard 301. Values shown are for installation type A: Free inlet hemispherical sone levels.

Roof Upblast/Sidewall Exhaust

Size-100: CUBE • CUE

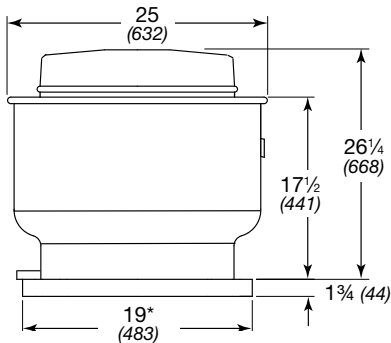

Direct Drive RPM

C-860 RPM
B-1140 RPM
A-1725 RPM
VG-1725 RPM

All dimensions in inches (millimeters), weight in pounds (kilograms).
 ^Weight shown is largest cataloged open drip-proof motor.

With Standard Curb Cap*

	CUBE	CUE
^Approximate Weight	66 (30)	64 (29)
Damper Size	12 x 12 (305 x 305)	
Roof/Wall (without wall bracket) Opening	15 1/2 x 15 1/2 (394 x 394)	
Wall Opening with Wall Bracket	15 x 15 (381 x 381)	
Wall Opening with a Curb Through Wall	19 x 19 (483 x 483)	

* Additional curb cap sizes available, see page 2

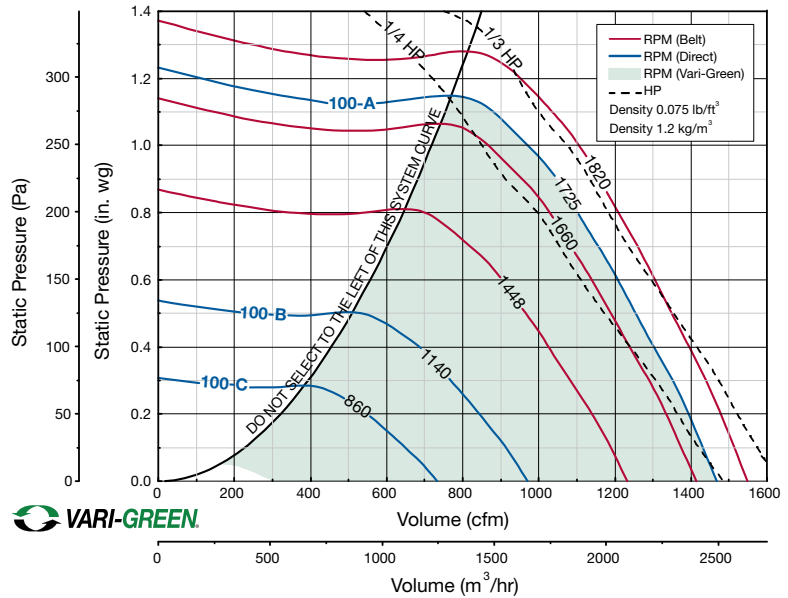

Motor HP	Fan RPM	Static Pressure in Inches wg																			
		0	0.125	0.25	0.375	0.5	0.625	0.75	0.875	1	1.125										
100																					
1/4	VG-1/4	C-1/8	860	CFM 732	625	481															
				BHP 0.03	0.035	0.036															
				Sones 4.6	2.1	1.3															
			953	CFM 811	717	603															
				BHP 0.041	0.047	0.05															
				Sones 5.5	4.2	3.1															
			1046	CFM 890	807	707	577														
				BHP 0.054	0.061	0.066	0.065														
				Sones 6.5	6.2	5.6	5.4														
		B-1/6	1140	CFM 970	897	806	707	411													
				BHP 0.07	0.078	0.084	0.085	0.067													
				Sones 7.2	7	6.5	6	5.5													
	1252		CFM 1066	1000	920	834	732														
			BHP 0.092	0.1	0.11	0.11	0.11														
			Sones 8	8	7.6	6.9	6.5														
		1350	CFM 1149	1089	1016	940	856	745													
		BHP 0.12	0.13	0.13	0.14	0.14	0.14														
		Sones 8.9	8.9	8.6	8.1	7.5	7														
		1448	CFM 1233	1176	1112	1040	966	886	763												
		BHP 0.14	0.15	0.16	0.17	0.17	0.17	0.17													
		Sones 10.3	10.2	9.9	9.5	9	8.3	8													
		1546	CFM 1316	1264	1206	1139	1072	999	915	793											
		BHP 0.17	0.19	0.2	0.2	0.21	0.21	0.21	0.21	0.23											
		Sones 11.8	11.5	11.3	10.9	10.5	9.8	9.3	8.9												
		1660	CFM 1413	1365	1313	1251	1189	1125	1056	974	861										
		BHP 0.22	0.23	0.24	0.25	0.26	0.26	0.26	0.26	0.25											
		Sones 12.7	12.3	12	11.6	11.3	10.8	10.2	9.6	9.4											
1/3	A-1/4	1725	CFM 1468	1422	1373	1315	1255	1195	1129	1062	970										
			BHP 0.24	0.26	0.27	0.28	0.29	0.29	0.29	0.29	0.29	0.29									
			Sones 13.3	12.9	12.5	12	11.7	11.3	10.8	10.2	9.7										
		1820	CFM 1549	1505	1459	1406	1350	1293	1234	1171	1106	900									
		BHP 0.28	0.3	0.31	0.32	0.33	0.34	0.35	0.35	0.35	0.35										
		Sones 14.3	13.7	13.4	12.7	12.4	12	11.6	11.2	10.6	10.1										

MAXIMUM BHP AT A
 GIVEN RPM = (RPM/3099)³
 MAXIMUM RPM = 1820
 TIP SPEED (ft/min) = RPM x 2.846
 MAXIMUM MOTOR FRAME SIZE = 56
 AVERAGE DISCHARGE VELOCITY
 (FPM) = CFM/1.28

Performance certified is for installation type A: Free inlet, Free outlet. Power rating (BHP) does not include transmission losses. Performance ratings do not include the effects of appurtenances (accessories). The sound ratings shown are loudness values in fan sones at 5 ft. (1.5 m) in a hemispherical free field calculated per AMCA Standard 301. Values shown are for installation type A: Free inlet hemispherical sone levels.

Roof Upblast/Sidewall Exhaust Size-100HP: CUBE • CUE

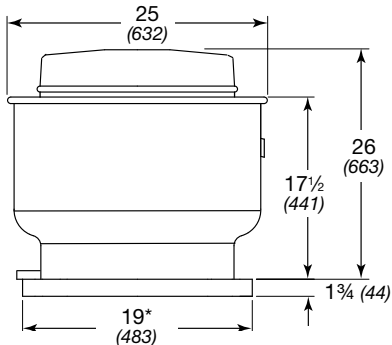

Direct Drive RPM

- VG-1725 RPM
- VG-2500 RPM

All dimensions in inches (millimeters), weight in pounds (kilograms).
^Weight shown is largest cataloged open drip-proof motor.

With Standard Curb Cap*	CUBE	CUE
^Approximate Weight	66 (30)	64 (29)
Damper Size	12 x 12 (305 x 305)	
Roof/Wall (without wall bracket) Opening	15½ x 15½ (394 x 394)	
Wall Opening with Wall Bracket	15 x 15 (381 x 381)	
Wall Opening with a Curb Through Wall	19 x 19 (483 x 483)	

* Additional curb cap sizes available, see page 2

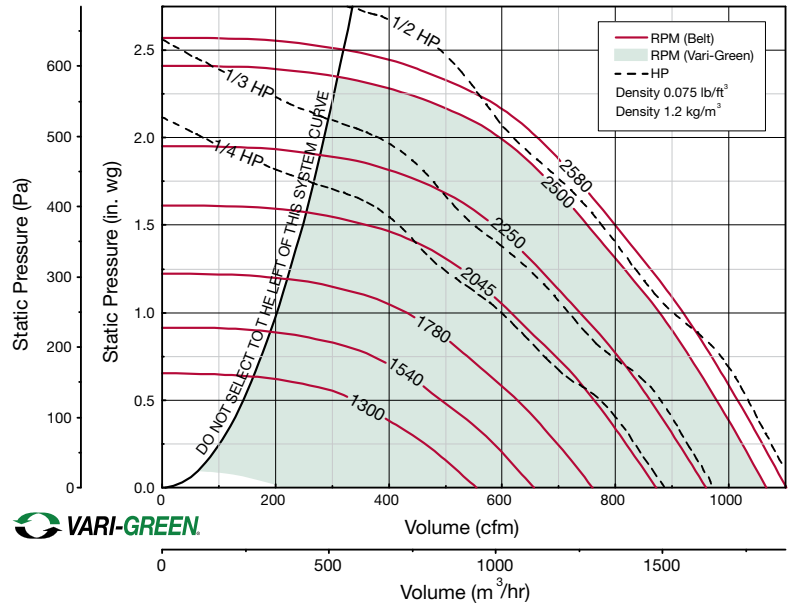

Motor HP	Fan RPM		Static Pressure in Inches wg									
			0.5	0.625	0.75	1	1.25	1.5	1.75	2	2.25	2.5
100HP												
1/4	VG-1/4	1300	CFM 335	182								
		BHP 0.067	0.056									
		Sones 6	6.3									
		1420	CFM 419	350	191							
		BHP 0.088	0.088	0.073								
		Sones 6.8	6.6	6.9								
	VG-1/2	1540	CFM 491	438	371							
		BHP 0.11	0.11	0.11								
		Sones 7.8	7.5	7.3								
		1660	CFM 560	512	461	262						
		BHP 0.14	0.14	0.14	0.12							
		Sones 8.9	8.6	8.4	8.3							
1/3	VG-1/2	1780	CFM 627	583	538	430						
		BHP 0.17	0.17	0.17	0.17							
		Sones 10.3	9.9	9.6	9.1							
		1900	CFM 688	651	610	520	382					
		BHP 0.2	0.21	0.21	0.21	0.19						
		Sones 12.1	11.4	11	10.5	10.2						
	VG-1/4	2045	CFM 761	729	693	615	522	346				
		BHP 0.24	0.26	0.26	0.26	0.26	0.23					
		Sones 13.9	13.5	12.7	12.1	11.5	11.4					
		2150	CFM 812	782	752	678	600	500				
		BHP 0.28	0.29	0.3	0.3	0.3	0.3					
		Sones 14.1	14.1	13.5	12.5	12	11.5					
1/2	VG-1/4	2250	CFM 860	832	804	737	665	579	456			
		BHP 0.32	0.33	0.34	0.35	0.35	0.35	0.32				
		Sones 14.4	14.4	14.2	13.2	12.5	11.9	11.6				
		2500	CFM 977	954	929	878	815	750	677	595	414	
		BHP 0.44	0.44	0.45	0.48	0.48	0.48	0.48	0.48	0.48	0.42	
		Sones 15.9	15.6	15.3	15	14.4	13.6	12.9	12.5	12.5	12.2	
1/2	VG-1/2	2580	CFM 1014	992	969	919	861	799	735	655	550	323
		BHP 0.48	0.48	0.49	0.52	0.53	0.53	0.53	0.53	0.53	0.49	0.43
		Sones 16.8	16.4	16	15.7	15.1	14.4	13.7	13.2	12.9	12.5	

MAXIMUM BHP AT A GIVEN RPM = (RPM/3195)³
 MAXIMUM RPM = 2580
 TIP SPEED (ft/min) = RPM x 2.913
 MAXIMUM MOTOR FRAME SIZE = 56
 AVERAGE DISCHARGE VELOCITY (FPM) = CFM/1.28

Performance certified is for installation type A: Free inlet, Free outlet. Power rating (BHP) does not include transmission losses. Performance ratings do not include the effects of appurtenances (accessories). The sound ratings shown are loudness values in fan sones at 5 ft. (1.5 m) in a hemispherical free field calculated per AMCA Standard 301. Values shown are for installation type A: Free inlet hemispherical sone levels.

Roof Upblast/Sidewall Exhaust

Size-120: CUBE • CUE

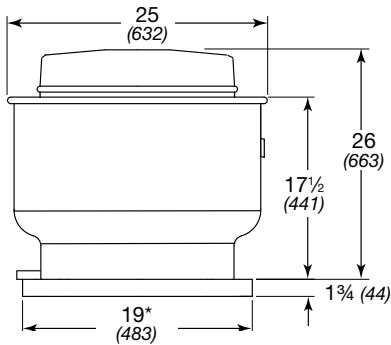

Direct Drive RPM

C-860 RPM
B-1140 RPM
A-1725 RPM
VG-1725 RPM

All dimensions in inches (millimeters), weight in pounds (kilograms).

*Weight shown is largest cataloged open drip-proof motor.

With Standard Curb Cap*

	CUBE	CUE
^Approximate Weight	66 (30)	64 (29)
Damper Size	12 x 12 (305 x 305)	
Roof/Wall (without wall bracket) Opening	15½ x 15½ (394 x 394)	
Wall Opening with Wall Bracket	15 x 15 (381 x 381)	
Wall Opening with a Curb Through Wall	19 x 19 (483 x 483)	

* Additional curb cap sizes available, see page 2

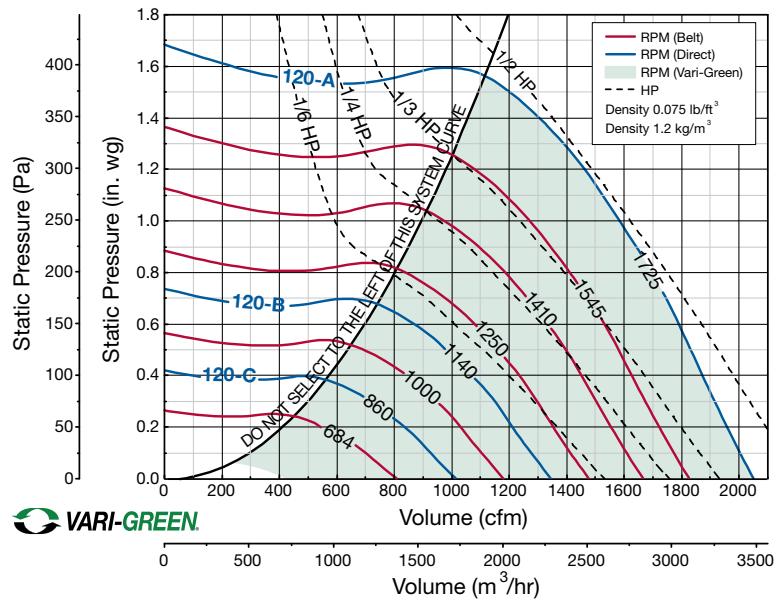

Motor HP		Fan RPM	Static Pressure in Inches wg																		
Belt	Direct		0	0.125	0.25	0.375	0.5	0.625	0.75	1	1.25	1.5									
120																					
1/4	VARI-GREEN	VG-1/4	684	CFM	808	669															
				BHP	0.02	0.03															
				Sones	4.4	4.4															
		C-1/8	860	CFM	912	789	630														
				BHP	0.04	0.04	0.043														
				Sones	4.8	5	5.1														
	B-1/6	1000	1140	CFM	1015	905	781	581													
				BHP	0.05	0.05	0.06	0.06													
				Sones	5.3	5.7	5.6	5.7													
		1250	1410	CFM	1181	1084	993	870	691												
				BHP	0.08	0.08	0.09	0.09	0.09												
				Sones	6.2	6.6	6.8	6.7	6.7												
1/3	VARI-GREEN	VG-1/2	1140	CFM	1346	1261	1180	1091	981	833											
				BHP	0.11	0.12	0.13	0.13	0.14	0.14											
				Sones	7.4	7.9	8.2	8.2	8	8.1											
	1/2	A-1/2	1725	CFM	1476	1397	1323	1250	1159	1053	916										
				BHP	0.15	0.16	0.17	0.17	0.18	0.18	0.18										
				Sones	8.8	9.3	9.9	9.9	10	9.8	9.8										
1/3	VARI-GREEN	VG-1/2	1480	CFM	1665	1595	1528	1463	1398	1315	1224	965									
				BHP	0.21	0.22	0.23	0.24	0.25	0.26	0.26	0.25									
				Sones	11.1	11.6	12.2	12.5	12.6	12.7	12.7	12.3									
	1/2	A-1/2	1725	CFM	1748	1681	1617	1555	1493	1421	1338	1132									
				BHP	0.25	0.26	0.27	0.28	0.29	0.29	0.30	0.30									
				Sones	11.9	12.4	13.1	13.5	13.7	13.8	13.8	13.6									
1/2	VARI-GREEN	VG-1/2	1545	CFM	1824	1760	1699	1639	1580	1518	1441	1262	990								
				BHP	0.28	0.29	0.30	0.31	0.32	0.33	0.34	0.34	0.33								
				Sones	12.8	13.4	14	14.5	14.7	14.8	14.9	14.9	14.6								
	1/2	A-1/2	1725	CFM	1931	1870	1811	1755	1699	1643	1577	1424	1226								
				BHP	0.33	0.34	0.36	0.37	0.38	0.39	0.40	0.41	0.40								
				Sones	14.1	14.7	15.2	15.9	16.2	16.4	16.6	16.7	16.5								
1/2	A-1/2	1725	CFM	2037	1979	1923	1869	1816	1763	1710	1571	1406	1176								
			BHP	0.39	0.40	0.41	0.43	0.44	0.45	0.46	0.47	0.48	0.46								
			Sones	15.6	16.1	16.7	17.3	17.9	18.2	18.4	18.7	18.6	18.4								

MAXIMUM BHP AT A GIVEN RPM = (RPM/2199)³
 MAXIMUM RPM = 1725
 TIP SPEED (ft/min) = RPM x 3.419
 MAXIMUM MOTOR FRAME SIZE = 56
 AVERAGE DISCHARGE VELOCITY (FPM) = CFM/1.28

Performance certified is for installation type A: Free inlet, Free outlet. Power rating (BHP) does not include transmission losses. Performance ratings do not include the effects of appurtenances (accessories). The sound ratings shown are loudness values in fan sones at 5 ft. (1.5 m) in a hemispherical free field calculated per AMCA Standard 301. Values shown are for installation type A: Free inlet hemispherical sone levels.

Roof Upblast/Sidewall Exhaust Size-130: CUBE • CUE

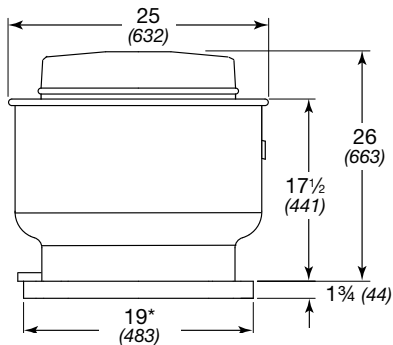

Direct Drive RPM

C-860 RPM
B-1140 RPM
A-1725 RPM
VG-1725 RPM

All dimensions in inches (millimeters), weight in pounds (kilograms).
^Weight shown is largest cataloged open drip-proof motor.

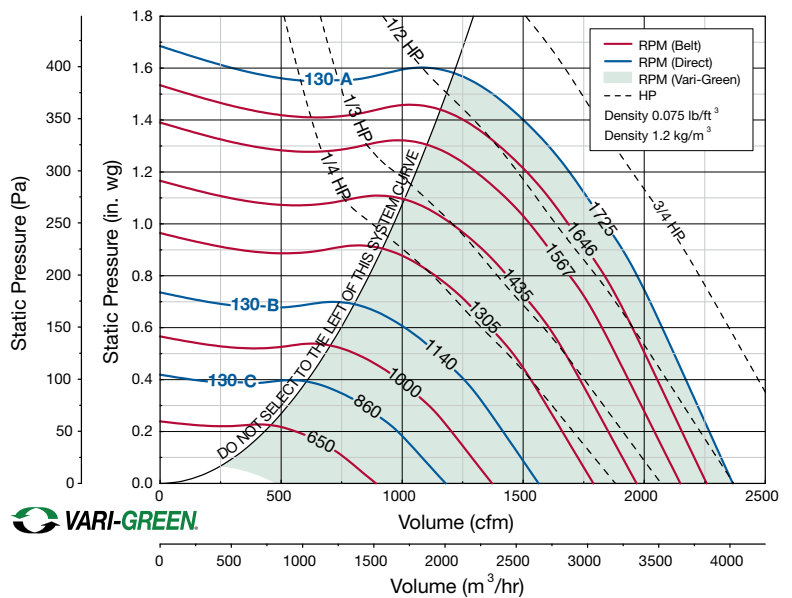

With Standard Curb Cap*	CUBE	CUE
^Approximate Weight	66 (30)	64 (29)
Damper Size	12 x 12 (305 x 305)	
Roof/Wall (without wall bracket) Opening	15 1/2 x 15 1/2 (394 x 394)	
Wall Opening with Wall Bracket	15 x 15 (381 x 381)	
Wall Opening with a Curb Through Wall	19 x 19 (483 x 483)	

* Additional curb cap sizes available, see page 2

Motor HP		Fan RPM	Static Pressure in Inches wg										
Belt	Direct		0	0.125	0.25	0.375	0.5	0.625	0.75	1	1.25	1.5	
130													
1/4	VARI-GREEN VG-1/4	650	CFM	892	724								
			BHP	0.03	0.03								
		755	Sones	6.2	6.0								
			CFM	1036	895	697							
		C-1/8	860	BHP	0.06	0.07	0.07	0.07					
			Sones	8.5	8.3	7.7	6.9						
	VARI-GREEN VG-1/2	1000	CFM	1372	1267	1158	1016	801					
			BHP	0.10	0.11	0.11	0.12	0.11					
		B-1/6	1140	Sones	10.7	10.5	10.0	9.2	8.3				
			CFM	1564	1471	1379	1280	1144	964				
		VG-1/2	1305	BHP	0.14	0.15	0.16	0.17	0.17	0.17			
			Sones	12.5	12.2	11.8	11.2	10.3	9.7				
1/3	VG-1/2	1435	CFM	1790	1709	1629	1547	1458	1340	1201			
		BHP	0.22	0.23	0.24	0.25	0.26	0.26	0.26				
	VG-3/4	1488	Sones	14.6	14.3	13.9	13.5	13.0	12.0	11.5			
		CFM	1968	1895	1822	1749	1671	1586	1479	1198			
	VG-3/4	1567	BHP	0.29	0.30	0.31	0.32	0.33	0.34	0.35	0.33		
		Sones	15.7	15.5	15.1	14.8	14.3	13.8	13.1	11.9			
1/2	VG-3/4	1646	CFM	2041	1970	1900	1829	1756	1679	1580	1342		
		BHP	0.32	0.33	0.35	0.36	0.37	0.38	0.39	0.38			
	A-1/2	1725	Sones	16.2	15.9	15.7	15.4	15.0	14.5	13.9	12.7		
		CFM	2149	2082	2015	1948	1881	1808	1728	1527	1222		
	A-1/2	1725	BHP	0.37	0.39	0.40	0.41	0.43	0.44	0.45	0.45	0.42	
		Sones	17.0	16.8	16.5	16.3	15.9	15.5	15.0	13.8	12.6		
X		1725	CFM	2258	2194	2130	2066	2002	1935	1865	1686	1458	
X		1725	BHP	0.43	0.45	0.46	0.47	0.49	0.50	0.51	0.52	0.51	
X		1725	Sones	17.9	17.6	17.4	17.2	16.9	16.5	16.1	15.1	14.0	
X		1725	CFM	2366	2305	2244	2183	2122	2061	1994	1838	1646	1365
X		1725	BHP	0.50	0.51	0.53	0.54	0.56	0.57	0.58	0.60	0.60	0.57
X		1725	Sones	18.8	18.6	18.4	18.2	18.0	17.6	17.2	16.4	15.3	14.1

MAXIMUM BHP AT A
GIVEN RPM = (RPM/2041)³
MAXIMUM RPM = 1725
TIP SPEED (ft/min) = RPM x 3.420
MAXIMUM MOTOR FRAME SIZE = 56
AVERAGE DISCHARGE VELOCITY
(FPM) = CFM/1.28

Performance certified is for installation type A: Free inlet, Free outlet. Power rating (BHP) does not include transmission losses. Performance ratings do not include the effects of appurtenances (accessories). The sound ratings shown are loudness values in fan sones at 5 ft. (1.5 m) in a hemispherical free field calculated per AMCA Standard 301. Values shown are for installation type A: Free inlet hemispherical sone levels.

Roof Upblast/Sidewall Exhaust

Size-140: CUBE • CUE • USGF

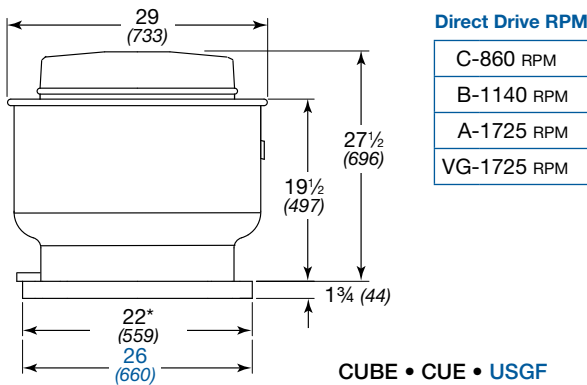

All dimensions in inches (millimeters), weight in pounds (kilograms).
 ^Weight shown is largest cataloged open drip-proof motor.

With Standard Curb Cap*	CUBE	CUE	USGF
^Approximate Weight	87 (39)	90 (41)	131 (59)
Damper Size	16 x 16 (406 x 406)		N/A
Roof/Wall (without wall bracket) Opening	18 1/2 x 18 1/2 (470 x 470)		
Wall Opening with Wall Bracket	18 x 18 (457 x 457)		N/A
Wall Opening with a Curb Through Wall	22 x 22 (559 x 559)		N/A
* Additional curb cap sizes available, see page 2			N/A

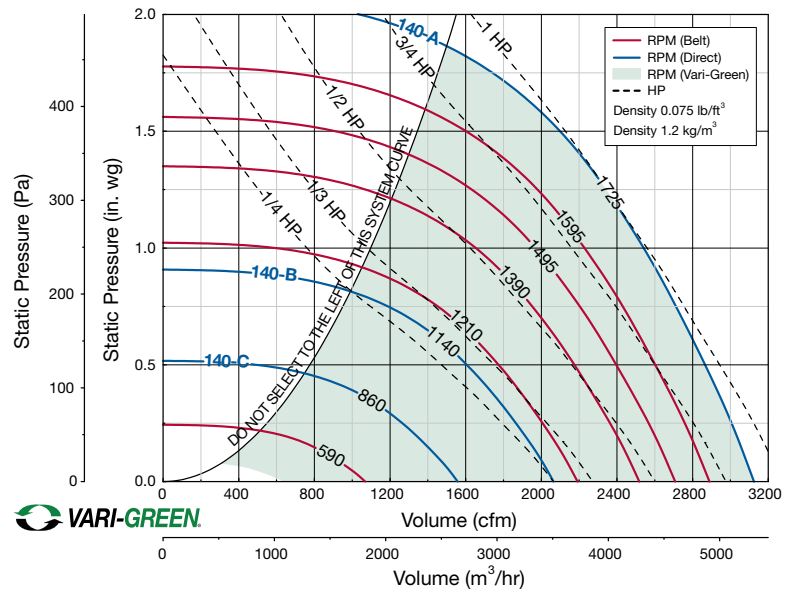

VARI-GREEN

Motor HP		Fan RPM	Static Pressure in Inches wg																			
Belt	Direct		0	0.125	0.25	0.375	0.5	0.75	1	1.25	1.50	1.75										
140																						
1/4	VARI-GREEN	VG-1/4	590	CFM	1069	851																
				BHP	0.04	0.04																
		725	CFM	1313	1151	917																
			BHP	0.06	0.07	0.07																
		C-1/8	860	CFM	1558	1427	1264	1034														
				BHP	0.11	0.12	0.12	0.12														
1105	CFM	2001	1906	1793	1667	1515	998															
	BHP	0.23	0.24	0.25	0.26	0.26	0.23															
1/3	VARI-GREEN	B-1/4	1140	CFM	2065	1973	1864	1745	1605	1167												
				BHP	0.25	0.26	0.27	0.28	0.29	0.27												
		1210	CFM	2192	2106	2006	1896	1773	1443													
			BHP	0.30	0.31	0.32	0.33	0.34	0.34													
		1390	CFM	2518	2445	2362	2271	2174	1949	1643												
			BHP	0.45	0.47	0.48	0.50	0.51	0.51	0.51												
3/4	VARI-GREEN	VG-3/4	1495	CFM	2708	2640	2565	2483	2396	2202	1967	1617										
				BHP	0.56	0.58	0.60	0.61	0.62	0.64	0.65	0.61										
		1550	CFM	2808	2743	2671	2594	2509	2329	2110	1823	1349										
			BHP	0.63	0.64	0.66	0.68	0.69	0.71	0.72	0.70	0.62										
		1595	CFM	2889	2826	2757	2683	2602	2430	2225	1968	1568										
			BHP	0.69	0.70	0.72	0.74	0.75	0.77	0.79	0.78	0.71										
1725	CFM	3124	3066	3005	2936	2865	2711	2539	2339	2085	1704											
	BHP	0.87	0.88	0.90	0.92	0.94	0.97	0.99	1.00	0.98	0.91											
1	VARI-GREEN	A-1	1725	CFM	3124	3066	3005	2936	2865	2711	2539	2339	2085	1704								
				BHP	0.87	0.88	0.90	0.92	0.94	0.97	0.99	1.00	0.98	0.91								
				Sones	26.0	23.0	22.0	24.0	24.0	15.1	13.4	14.3	13.8	13.8								

MAXIMUM BHP AT A GIVEN RPM = (RPM/1726)³
 MAXIMUM RPM = 1725
 TIP SPEED (ft/min) = RPM x 3.829
 MAXIMUM MOTOR FRAME SIZE = 145T
 AVERAGE DISCHARGE VELOCITY (FPM) = CFM/1.72

Performance certified is for installation type A: Free inlet, Free outlet. Power rating (BHP) does not include transmission losses. Performance ratings do not include the effects of appurtenances (accessories). The sound ratings shown are loudness values in fan sones at 5 ft. (1.5 m) in a hemispherical free field calculated per AMCA Standard 301. Values shown are for installation type A: Free inlet hemispherical sone levels.

Roof Upblast/Sidewall Exhaust Size-140HP: CUBE • CUE • USGF

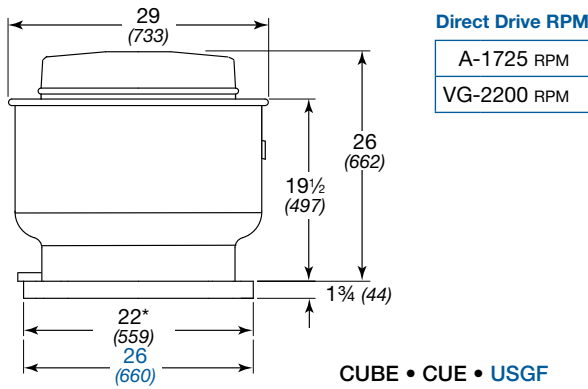

All dimensions in inches (millimeters), weight in pounds (kilograms).
^Weight shown is largest cataloged open drip-proof motor.

With Standard Curb Cap*	CUBE	CUE	USGF
^Approximate Weight	87 (39)	90 (41)	131 (59)
Damper Size	16 x 16 (406 x 406)	N/A	
Roof/Wall (without wall bracket) Opening	18½ x 18½ (470 x 470)		
Wall Opening with Wall Bracket	18 x 18 (457 x 457)	N/A	
Wall Opening with a Curb Through Wall	22 x 22 (559 x 559)	N/A	
* Additional curb cap sizes available, see page 2	N/A		

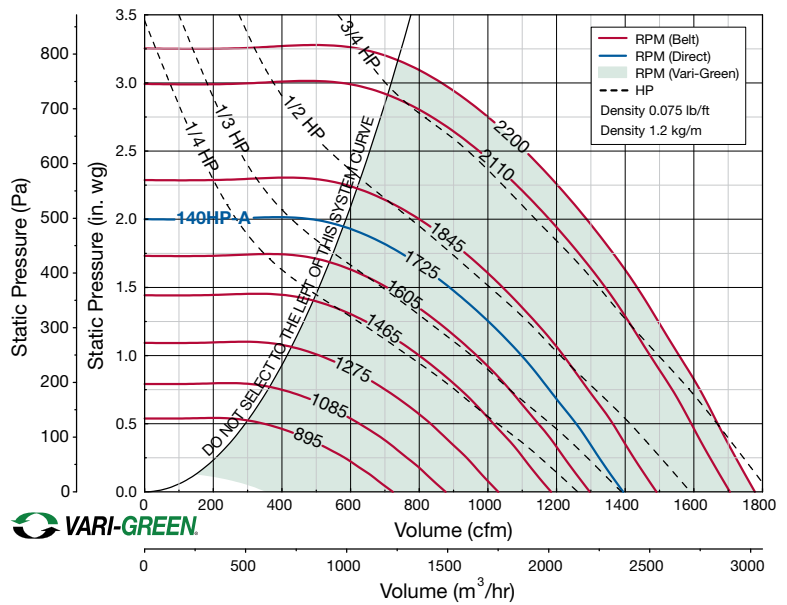

Motor HP		Fan RPM	Static Pressure in Inches wg										
Belt	Direct		0.5	0.75	1	1.25	1.5	1.75	2	2.25	2.50	2.75	
140HP													
1/4	VARI-GREEN VG-1/4	895	CFM	331									
			BHP	0.06									
		Sones	5.7										
		1085	CFM	625	377								
			BHP	0.11	0.10								
		Sones	7.5	9.5									
	1275	CFM	833	700	492								
		BHP	0.17	0.17	0.16								
	Sones	11.0	10.5	13.9									
	1465	CFM	1016	920	798	642							
		BHP	0.24	0.26	0.26	0.26							
	Sones	14.2	13.5	13.3	15.5								
1/3	VARI-GREEN VG-1/2	1605	CFM	1146	1063	965	846	704					
			BHP	0.31	0.33	0.34	0.34	0.34					
			Sones	15.3	14.4	14.2	14.0	15.3					
1/2	A-1/2	1725	CFM	1256	1178	1098	999	879	747				
			BHP	0.38	0.40	0.42	0.43	0.43	0.42				
		Sones	16.2	15.4	15.0	14.9	14.7	15.7					
		1845	CFM	1363	1292	1219	1137	1042	924	800			
			BHP	0.46	0.48	0.50	0.52	0.52	0.52	0.51			
		Sones	17.1	16.6	16.1	16.0	15.9	15.7	16.2				
3/4	VARI-GREEN VG-3/4	1960	CFM	1463	1399	1330	1260	1176	1086	970	854		
			BHP	0.54	0.57	0.59	0.61	0.62	0.63	0.62	0.62		
		Sones	18.1	17.8	17.4	17.2	17.1	17.0	16.8	17.0			
		2035	CFM	1528	1468	1402	1335	1261	1175	1077	965	826	
			BHP	0.60	0.63	0.66	0.68	0.69	0.70	0.70	0.69	0.67	
		Sones	19.0	18.6	18.3	18.1	18.0	17.9	17.7	17.5	17.9		
2110	CFM	1592	1536	1473	1409	1341	1262	1178	1073	965	804		
	BHP	0.67	0.70	0.72	0.75	0.77	0.78	0.78	0.78	0.77	0.73		
Sones	19.9	19.4	19.2	19.1	19.0	18.8	18.7	18.5	18.3	20.0			
2200	CFM	1669	1617	1557	1496	1434	1364	1284	1200	1097	993		
	BHP	0.75	0.78	0.81	0.84	0.86	0.87	0.88	0.88	0.88	0.87		
Sones	21.0	21.0	20.0	20.0	20.0	20.0	20.0	19.9	19.7	19.5	19.3		

MAXIMUM BHP AT A
GIVEN RPM = (RPM/2285)³
MAXIMUM RPM = 2200
TIP SPEED (ft/min) = RPM x 3.829
MAXIMUM MOTOR FRAME SIZE = 145T
AVERAGE DISCHARGE VELOCITY
(FPM) = CFM/1.72

Performance certified is for installation type A: Free inlet, Free outlet. Power rating (BHP) does not include transmission losses. Performance ratings do not include the effects of appurtenances (accessories). The sound ratings shown are loudness values in fan sones at 5 ft. (1.5 m) in a hemispherical free field calculated per AMCA Standard 301. Values shown are for installation type A: Free inlet hemispherical sone levels.

Roof Upblast/Sidewall Exhaust

Size-160: CUBE • CUE • USGF

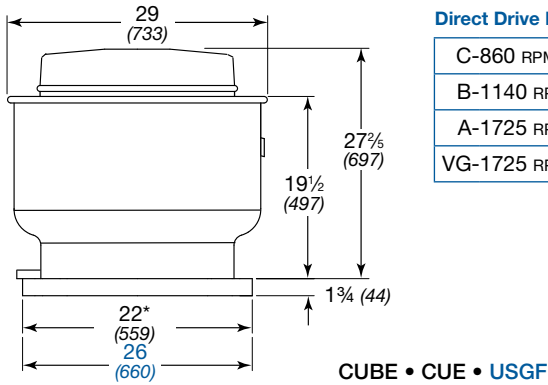

All dimensions in inches (millimeters), weight in pounds (kilograms).
 ^Weight shown is largest cataloged open drip-proof motor.

With Standard Curb Cap*	CUBE	CUE	USGF
^Approximate Weight	87 (39)	90 (41)	131 (59)
Damper Size	16 x 16 (406 x 406)		N/A
Roof/Wall (without wall bracket) Opening	18½ x 18½ (470 x 470)		
Wall Opening with Wall Bracket	18 x 18 (457 x 457)	N/A	
Wall Opening with a Curb Through Wall	22 x 22 (559 x 559)	N/A	
* Additional curb cap sizes available, see page 2	N/A		

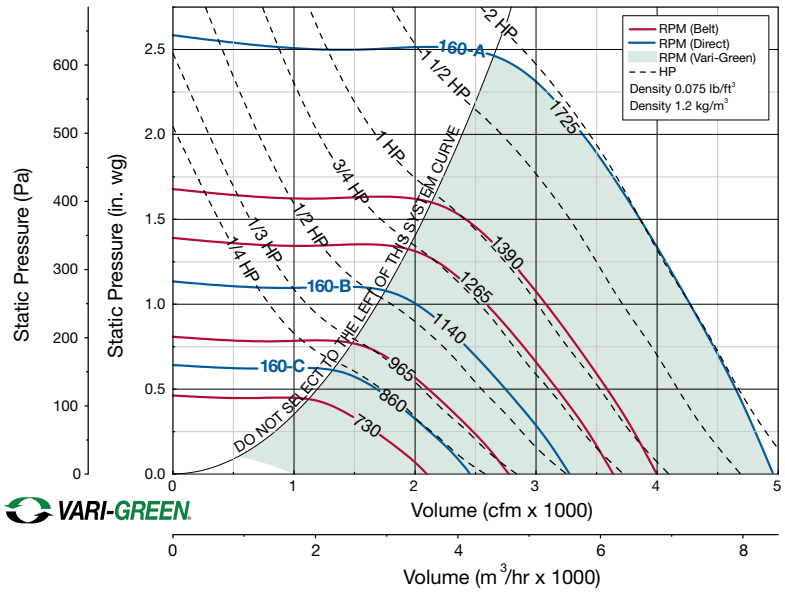

VARI-GREEN

Motor HP		Fan RPM	Static Pressure in Inches wg										
Belt	Direct		0	0.125	0.25	0.375	0.5	0.625	0.75	0.875	1	1.5	
160													
1/4	VARI-GREEN VG-1/2	730	CFM	2098	1905	1669	1389						
			BHP	0.13	0.15	0.15	0.15						
			Sones	8.1	8	7.8	7.8						
		805	CFM	2314	2143	1937	1708	1396					
			BHP	0.18	0.20	0.20	0.20	0.19					
			Sones	9.5	9.2	8.9	8.8	8.7					
	C-1/4	860	CFM	2472	2315	2126	1918	1680					
			BHP	0.22	0.24	0.25	0.25	0.24					
			Sones	10.7	10.2	9.9	9.7	9.5					
		875	CFM	2515	2362	2177	1974	1744	1365				
			BHP	0.23	0.26	0.26	0.26	0.26	0.24				
			Sones	11	10.6	10.1	9.9	9.7	9.7				
1/3	965	CFM	2774	2637	2477	2300	2109	1893	1584				
		BHP	0.31	0.34	0.35	0.35	0.35	0.34	0.33				
		Sones	12.4	12	11.5	11.2	10.8	10.6	10.6				
1/2	VG-3/4	1110	CFM	3191	3072	2941	2796	2641	2475	2297	1770		
			BHP	0.47	0.51	0.53	0.53	0.54	0.53	0.52	0.49		
			Sones	15	14.6	14.2	13.8	13.5	13.1	12.9	12.5		
	3/4	B-1/2	1140	CFM	3277	3161	3035	2896	2745	2587	2421	1983	
				BHP	0.51	0.55	0.57	0.57	0.58	0.58	0.57	0.55	
				Sones	15.7	15.2	14.8	14.4	14.1	13.8	13.5	13.2	
1	VG-1	1265	CFM	3636	3532	3426	3301	3172	3036	2894	2583	2163	
			BHP	0.70	0.74	0.77	0.78	0.79	0.79	0.79	0.78	0.75	
			Sones	18.5	18.1	17.6	17.2	16.8	16.5	16.3	15.8	15.6	
	1300	CFM	3737	3636	3534	3413	3290	3157	3022	2729	2357		
		BHP	0.76	0.80	0.84	0.85	0.85	0.86	0.86	0.84	0.82		
		Sones	19.1	18.7	18.3	17.9	17.5	17.2	17	16.5	16.3		
1390	CFM	3996	3901	3806	3698	3584	3464	3340	3078	2785	2394		
	BHP	0.93	0.97	1.01	1.03	1.04	1.04	1.05	1.04	1.03	1.00		
	Sones	21	21	20	19.7	19.3	19	18.8	18.4	18	17.9		
A-2	1725	CFM	4959	4882	4806	4729	4646	4554	4463	4269	4070	3855	
		BHP	1.77	1.83	1.88	1.94	1.97	1.97	1.98	2.00	2.01	1.99	
		Sones	30	29	29	29	28	28	27	27	27	26	

MAXIMUM BHP AT A
 GIVEN RPM = (RPM/1365)³
 MAXIMUM RPM = 1725
 TIP SPEED (ft/min) = RPM x 4.352
 MAXIMUM MOTOR FRAME SIZE = 145T
 AVERAGE DISCHARGE VELOCITY
 (FPM) = CFM/1.72

Performance certified is for installation type A: Free inlet, Free outlet. Power rating (BHP) does not include transmission losses. Performance ratings do not include the effects of appurtenances (accessories). The sound ratings shown are loudness values in fan sones at 5 ft. (1.5 m) in a hemispherical free field calculated per AMCA Standard 301. Values shown are for installation type A: Free inlet hemispherical sone levels.

Roof Upblast/Sidewall Exhaust Size-160HP: CUBE • CUE • USGF

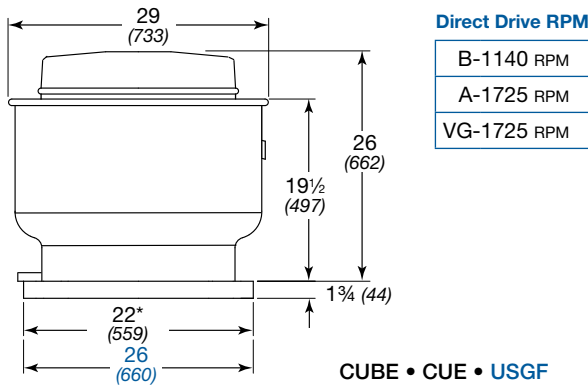

All dimensions in inches (millimeters), weight in pounds (kilograms).
^Weight shown is largest cataloged open drip-proof motor.

With Standard Curb Cap*	CUBE	CUE	USGF
^Approximate Weight	87 (39)	90 (41)	131 (59)
Damper Size	16 x 16 (406 x 406)		N/A
Roof/Wall (without wall bracket) Opening	18½ x 18½ (470 x 470)		
Wall Opening with Wall Bracket	18 x 18 (457 x 457)	N/A	
Wall Opening with a Curb Through Wall	22 x 22 (559 x 559)	N/A	
* Additional curb cap sizes available, see page 2	N/A		

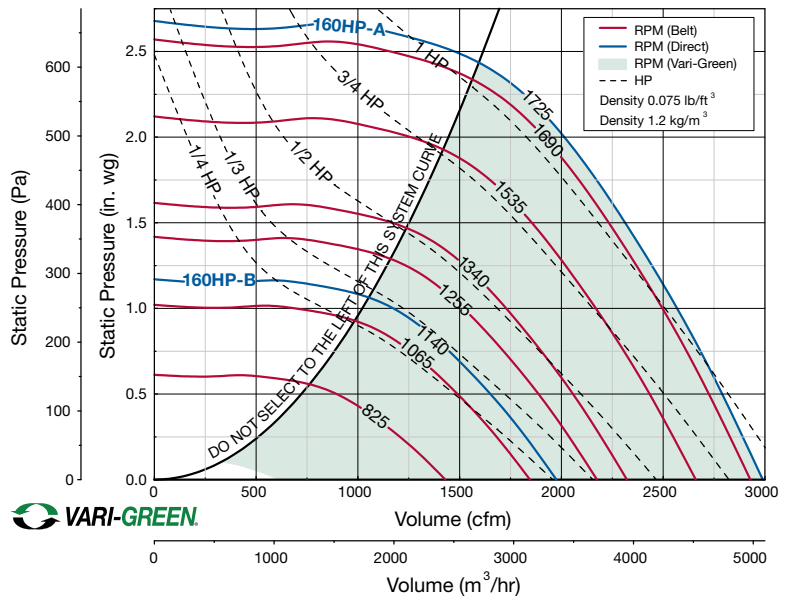

Motor HP	Fan RPM	Static Pressure in Inches wg											
		0.5	0.625	0.75	0.875	1	1.25	1.5	1.75	2	2.25		
160HP													
1/4	VG-1/2	825	CFM	889									
			BHP	0.12									
			Sones	6.1									
		945	CFM	1213	1062								
			BHP	0.18	0.18								
			Sones	8.9	8.4								
	1/3	B-1/3	1065	CFM	1487	1377	1252	1093					
				BHP	0.25	0.26	0.26	0.26					
				Sones	11.1	10.7	10.3	9.7					
			1140	CFM	1645	1552	1444	1322	1175				
				BHP	0.31	0.32	0.32	0.32	0.32				
				Sones	12.7	12.5	12	11.6	11				
1/2	VG-3/4	1165	CFM	1697	1608	1504	1395	1252					
			BHP	0.32	0.33	0.34	0.34	0.34					
			Sones	12.9	12.8	12.3	11.8	11.2					
		1255	CFM	1882	1799	1715	1617	1519	1218				
			BHP	0.40	0.41	0.42	0.43	0.43	0.42				
			Sones	13.1	12.8	12.5	12	11.5	10.6				
3/4	VG-3/4	1340	CFM	2053	1975	1897	1816	1724	1513				
			BHP	0.48	0.49	0.50	0.51	0.52	0.52				
			Sones	14.2	13.8	13.3	12.9	12.4	11.3				
		1535	CFM	2433	2368	2301	2233	2165	2015	1855	1638		
			BHP	0.70	0.72	0.73	0.74	0.76	0.78	0.79	0.78		
			Sones	18.1	17.7	17.3	16.9	16.5	15.6	14.7	13.5		
1	VG-1	1550	CFM	2461	2398	2331	2264	2197	2051	1892	1683	1352	
			BHP	0.72	0.74	0.75	0.76	0.78	0.80	0.81	0.81	0.77	
			Sones	18.3	17.9	17.5	17.1	16.7	15.9	15	13.8	14.5	
		1690	CFM	2722	2671	2611	2550	2488	2365	2228	2082	1899	1664
			BHP	0.92	0.94	0.95	0.97	0.98	1.01	1.03	1.05	1.05	1.03
			Sones	21	21	20	19.8	19.4	18.7	18	17.3	16.1	15.1
A-1 1/2	1725	CFM	2787	2736	2680	2620	2560	2439	2310	2167	2003	1810	
		BHP	0.97	0.99	1.01	1.03	1.04	1.07	1.10	1.11	1.12	1.11	
		Sones	22	21	21	21	20	19.4	18.7	18	17.1	16	

MAXIMUM BHP AT A
GIVEN RPM = (RPM/1660)³
MAXIMUM RPM = 1725
TIP SPEED (ft/min) = RPM x 4.352
MAXIMUM MOTOR FRAME SIZE = 145T
AVERAGE DISCHARGE VELOCITY
(FPM) = CFM/1.72

Performance certified is for installation type A: Free inlet, Free outlet. Power rating (BHP) does not include transmission losses. Performance ratings do not include the effects of appurtenances (accessories). The sound ratings shown are loudness values in fan sones at 5 ft. (1.5 m) in a hemispherical free field calculated per AMCA Standard 301. Values shown are for installation type A: Free inlet hemispherical sone levels.

Roof Upblast/Sidewall Exhaust Size-160XP: CUBE • CUE • USGF

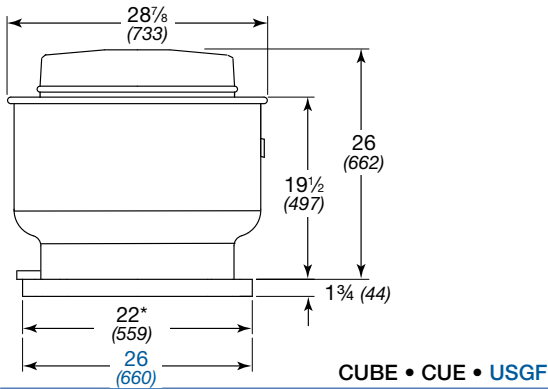

All dimensions in inches (millimeters), weight in pounds (kilograms).
^Weight shown is largest cataloged open drip-proof motor.

With Standard Curb Cap*	CUBE	CUE	USGF
^Approximate Weight	87 (39)	90 (41)	131 (59)
Damper Size	16 x 16 (406 x 406)		N/A
Roof/Wall (without wall bracket) Opening	18 ¹ / ₂ x 18 ¹ / ₂ (470 x 470)		
Wall Opening with Wall Bracket	18 x 18 (457 x 457)	N/A	
Wall Opening with a Curb Through Wall	22 x 22 (559 x 559)	N/A	
* Additional curb cap sizes available, see page 2	N/A		

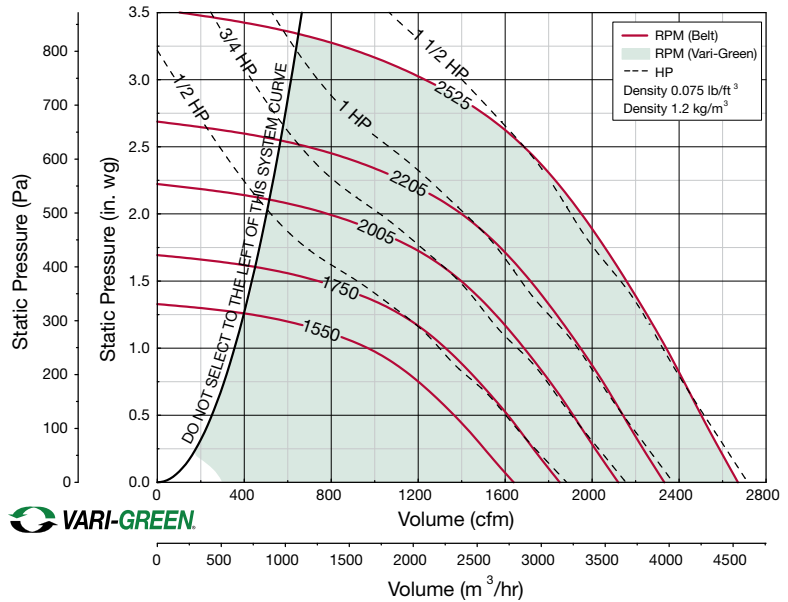

Motor HP		Fan RPM	Static Pressure in Inches wg										
Belt	Direct		1	1.25	1.5	1.75	2	2.25	2.5	2.75	3	3.25	
160XP													
1/2	VG-1	1550	CFM	968									
			BHP	0.34									
			Sones	10.0									
		1648	CFM	1157	854								
			BHP	0.42	0.39								
			Sones	11.1	10.1								
1750	CFM	1322	1116	726									
	BHP	0.52	0.49	0.43									
	Sones	12.1	11.4	10.6									
3/4	VG-1	1880	CFM	1515	1359	1139	744						
			BHP	0.7	0.6	0.6	0.5						
			Sones	13.7	13.1	12.2	11.8						
		1942	CFM	1599	1456	1271	984						
			BHP	0.71	0.7	0.68	0.63						
			Sones	14.4	14	13.2	12.4						
2005	CFM	1684	1552	1392	1161	777							
	BHP	0.77	0.78	0.76	0.72	0.63							
	Sones	15.0	14.8	14.1	13.4	13.2							
1	VG-1	2138	CFM	1861	1743	1611	1451	1226	869				
			BHP	0.9	1.0	0.9	0.9	0.9	0.8				
			Sones	16.6	16.4	15.9	15.4	14.8	14.8				
		2205	CFM	1946	1834	1713	1578	1395	1127	634			
			BHP	1.01	1.03	1.04	1.01	0.99	0.92	0.73			
			Sones	17.5	17.3	17	16.4	15.8	15.5	16.4			
1 1/2	VG-2	2310	CFM	2065	1974	1865	1741	1597	1415	1134	644		
			BHP	1.17	1.18	1.2	1.18	1.16	1.12	1.04	0.83		
			Sones	18.8	18.7	18.5	18.1	17.5	17	16.9	18.2		
		2432	CFM	2206	2132	2031	1926	1804	1660	1483	1225	826	
			BHP	1.36	1.36	1.38	1.4	1.38	1.35	1.31	1.23	1.07	
			Sones	21	20	20	20	19.6	19.1	18.7	18.7	19.8	
2525	CFM	2313	2241	2155	2056	1946	1828	1676	1487	1221	810		
	BHP	1.52	1.52	1.54	1.56	1.56	1.53	1.5	1.45	1.35	1.16		
	Sones	22	22	22	22	21	21	20	20	20	22		

MAXIMUM BHP AT A GIVEN RPM = (RPM/2170)³
 MAXIMUM RPM = 2525
 TIP SPEED (ft/min) = RPM x 3.534
 MAXIMUM MOTOR FRAME SIZE = 145T
 AVERAGE DISCHARGE VELOCITY (FPM) = CFM/1.72

Performance certified is for installation type A: Free inlet, Free outlet. Power rating (BHP) does not include transmission losses. Performance ratings do not include the effects of appurtenances (accessories). The sound ratings shown are loudness values in fan sones at 5 ft. (1.5 m) in a hemispherical free field calculated per AMCA Standard 301. Values shown are for installation type A: Free inlet hemispherical sone levels.

Roof Upblast/Sidewall Exhaust Size-180: CUBE • CUE • USGF

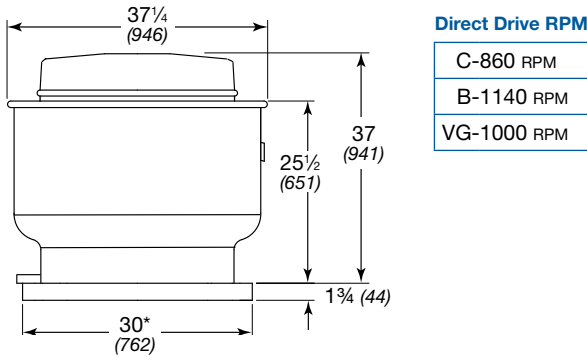

Direct Drive RPM

C-860 RPM
B-1140 RPM
VG-1000 RPM

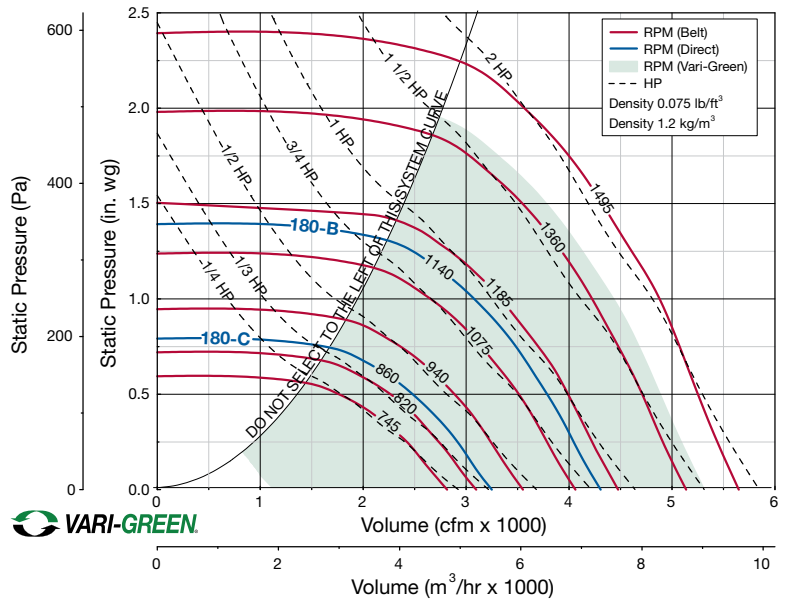

All dimensions in inches (millimeters), weight in pounds (kilograms).
 ^Weight shown is largest cataloged open drip-proof motor.

With Standard Curb Cap*	CUBE	CUE	USGF
^Approximate Weight	126 (57)	142 (64)	190 (86)
Damper Size	24 x 24 (610 x 610)		N/A
Roof/Wall (without wall bracket) Opening	26½ x 26½ (673 x 673)		
Wall Opening with Wall Bracket	26 x 26 (660 x 660)	N/A	
Wall Opening with a Curb Through Wall	30 x 30 (762 x 762)	N/A	

Motor HP		Fan RPM	Static Pressure in Inches wg										
Belt	Direct		0	0.125	0.25	0.5	0.75	1	1.25	1.5	1.75	2	
180													
1/4	VG-3/4	745	CFM	2815	2617	2448	1763						
			BHP	0.22	0.24	0.26	0.25						
1/3	VG-1	820	CFM	3098	2916	2759	2257						
			BHP	0.30	0.32	0.34	0.34						
1/2	VG-1	860	CFM	3249	3074	2922	2474						
			BHP	0.34	0.37	0.39	0.40						
3/4	VG-1	940	CFM	3551	3389	3243	2879	2363					
			BHP	0.45	0.47	0.49	0.52	0.50					
1	VG-2	1000	CFM	3778	3625	3486	3190	2738					
			BHP	0.54	0.57	0.59	0.63	0.62					
1 1/2	VG-2	1075	CFM	4061	3919	3786	3554	3141	2652				
			BHP	0.67	0.70	0.73	0.78	0.78	0.75				
2	VG-2	1140	CFM	4307	4173	4045	3822	3470	3072	2477			
			BHP	0.80	0.83	0.86	0.91	0.93	0.92	0.85			
1	VG-2	1185	CFM	4477	4348	4224	4005	3703	3336	2841			
			BHP	0.90	0.93	0.96	1.01	1.04	1.04	0.99			
1 1/2	VG-2	1275	CFM	4817	4697	4578	4369	4163	3799	3437	2930		
			BHP	1.12	1.15	1.19	1.24	1.30	1.30	1.28	1.22		
1 1/2	VG-2	1360	CFM	5138	5026	4913	4710	4532	4232	3912	3537	3023	
			BHP	1.36	1.39	1.43	1.49	1.56	1.58	1.58	1.54	1.46	
2	VG-2	1495	CFM	5648	5546	5443	5254	5082	4921	4598	4313	3983	3564
			BHP	1.80	1.84	1.89	1.96	2.02	2.10	2.10	2.10	2.06	1.99
2	VG-2	1495	CFM	5648	5546	5443	5254	5082	4921	4598	4313	3983	3564
			BHP	1.80	1.84	1.89	1.96	2.02	2.10	2.10	2.10	2.06	1.99

MAXIMUM BHP AT A GIVEN RPM = (RPM/1167)³
 MAXIMUM RPM = 1495
 TIP SPEED (ft/min) = RPM x 4.843
 AVERAGE DISCHARGE VELOCITY (FPM) = CFM/2.92

Performance certified is for installation type A: Free inlet, Free outlet. Power rating (BHP) does not include transmission losses. Performance ratings do not include the effects of appurtenances (accessories). The sound ratings shown are loudness values in fan sones at 5 ft. (1.5 m) in a hemispherical free field calculated per AMCA Standard 301. Values shown are for installation type A: Free inlet hemispherical sone levels.

Roof Upblast/Sidewall Exhaust Size-180HP: CUBE • CUE • USGF

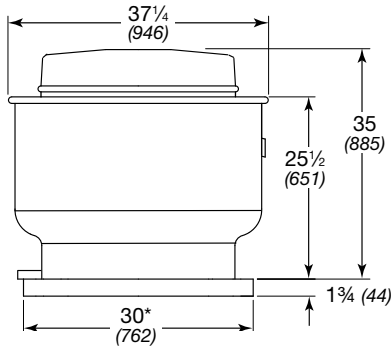

Direct Drive RPM
A-1725 RPM

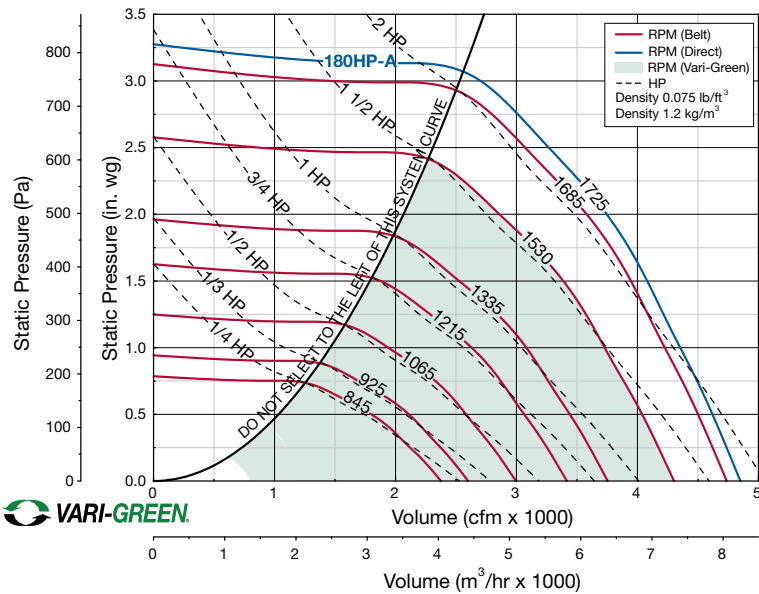

All dimensions in inches (millimeters), weight in pounds (kilograms).
^Weight shown is largest cataloged open drip-proof motor.

With Standard Curb Cap*	CUBE	CUE	USGF
^Approximate Weight	126 (57)	142 (64)	190 (86)
Damper Size	24 x 24 (610 x 610)	N/A	
Roof/Wall (without wall bracket) Opening	26½ x 26½ (673 x 673)		
Wall Opening with Wall Bracket	26 x 26 (660 x 660)	N/A	
Wall Opening with a Curb Through Wall	30 x 30 (762 x 762)	N/A	



Motor HP		Fan RPM	Static Pressure in Inches wg											
Belt	Direct		0.5	0.75	1	1.25	1.5	1.75	2	2.25	2.5	2.75		
180HP														
1/4	VG-1	845	CFM	1799										
			BHP	0.26										
			Sones	9.6										
		1/3	925	CFM	2104	1688								
				BHP	0.34	0.35								
				Sones	10.8	9.9								
		1/2	1065	CFM	2581	2323	1933							
				BHP	0.50	0.52	0.53							
				Sones	14.1	12.6	12.5							
		3/4	1215	CFM	3063	2868	2626	2286	1854					
				BHP	0.72	0.76	0.78	0.79	0.75					
				Sones	15.4	14.8	14.2	13.5	12.7					
1	1275	CFM	3253	3066	2853	2566	2209							
		BHP	0.82	0.87	0.89	0.91	0.89							
		Sones	17	16.2	15.6	15.1	14.3							
1/2	VG-2	1335	CFM	3441	3261	3075	2839	2523	2156					
			BHP	0.93	0.98	1.02	1.04	1.04	1.01					
			Sones	19	17.8	17.3	16.8	16.3	15.7					
1 1/2	1430	CFM	3735	3566	3401	3206	2964	2669	2320					
		BHP	1.13	1.19	1.23	1.26	1.27	1.28	1.24					
		Sones	22	21	20	19.6	19.2	18.8	18.2					
2	1530	CFM	4035	3884	3728	3574	3376	3135	2859	2534				
		BHP	1.36	1.43	1.48	1.53	1.55	1.56	1.57	1.53				
		Sones	24	23	22	21	21	20	19.7	19.1				
2	1610	CFM	4273	4136	3986	3840	3674	3485	3233	2965	2656	1557		
		BHP	1.58	1.64	1.70	1.76	1.79	1.81	1.82	1.82	1.78	1.38		
		Sones	26	24	24	23	22	22	21	20	19.8	18.3		
2	1685	CFM	4495	4369	4226	4085	3945	3768	3575	3325	3061	2766		
		BHP	1.79	1.86	1.93	1.99	2.04	2.07	2.08	2.09	2.08	2.04		
		Sones	28	27	26	26	25	23	22	22	21	21		
A-2	1725	CFM	4613	4493	4353	4215	4078	3917	3740	3509	3265	2984		
		BHP	1.92	1.99	2.06	2.12	2.18	2.21	2.23	2.24	2.25	2.21		
		Sones	29	28	27	29	27	25	24	23	22	21		

MAXIMUM BHP AT A
GIVEN RPM = (RPM/1315)³
MAXIMUM RPM = 1725
TIP SPEED (ft/min) = RPM x 4.843
MAXIMUM MOTOR FRAME SIZE = 184T
AVERAGE DISCHARGE VELOCITY
(FPM) = CFM/2.92

Performance certified is for installation type A: Free inlet, Free outlet. Power rating (BHP) does not include transmission losses. Performance ratings do not include the effects of appurtenances (accessories). The sound ratings shown are loudness values in fan sones at 5 ft. (1.5 m) in a hemispherical free field calculated per AMCA Standard 301. Values shown are for installation type A: Free inlet hemispherical sone levels.

Roof Upblast/Sidewall Exhaust Size-200: CUBE • CUE • USGF

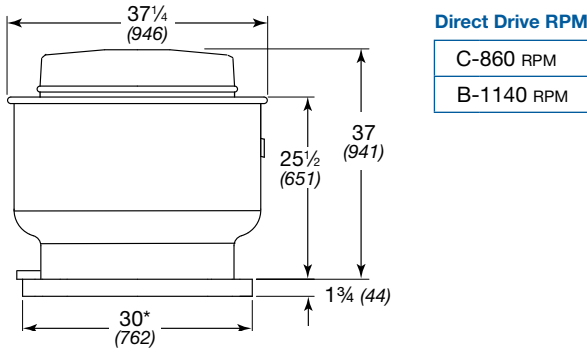

Direct Drive RPM

C-860 RPM
B-1140 RPM

All dimensions in inches (millimeters), weight in pounds (kilograms).
^Weight shown is largest cataloged open drip-proof motor.

With Standard Curb Cap*	CUBE	CUE	USGF
^Approximate Weight	142 (64)	170 (77)	213 (97)
Damper Size	24 x 24 (610 x 610)	N/A	N/A
Roof/Wall (without wall bracket) Opening	26 1/2 x 26 1/2 (673 x 673)		
Wall Opening with Wall Bracket	26 x 26 (660 x 660)		
Wall Opening with a Curb Through Wall	30 x 30 (762 x 762)	N/A	N/A

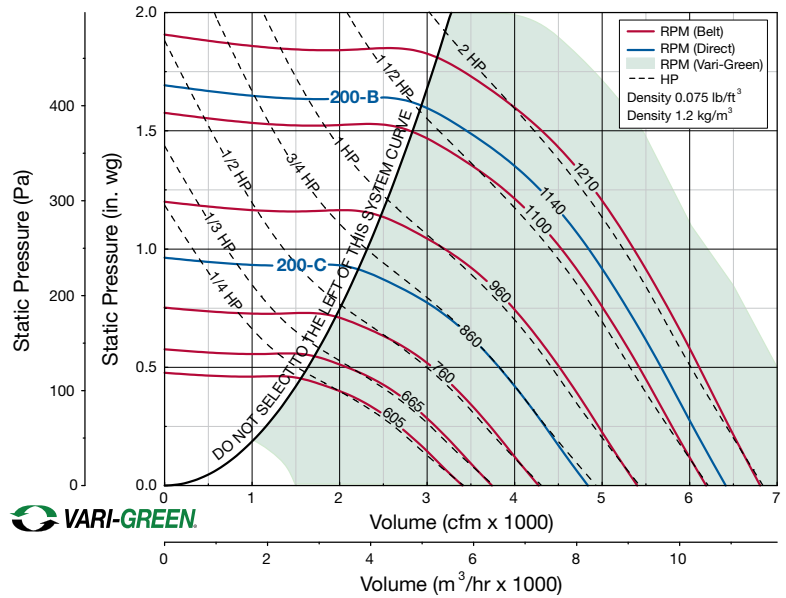

Motor HP		Fan RPM	Static Pressure in Inches wg												
Belt	Direct		0	0.125	0.25	0.375	0.5	0.75	1	1.25	1.5	1.75			
200															
1/4	VG-1	605	CFM	3403	3054	2675	2144								
			BHP	0.25	0.26	0.26	0.25								
			Sones	8.2	7.6	6.8	6.2								
		1/3	665	CFM	3740	3422	3096	2699	2073						
				BHP	0.33	0.34	0.35	0.35	0.33						
				Sones	9.6	9	8.3	7.5	7.2						
		1/2	760	CFM	4275	3994	3718	3413	3048						
				BHP	0.49	0.51	0.52	0.52	0.51						
				Sones	12.3	11.8	11.1	10.2	9.5						
		3/4	C-3/4	820	CFM	4612	4350	4098	3828	3523	2606				
					BHP	0.61	0.63	0.65	0.65	0.65	0.61				
					Sones	14.2	14.1	13.3	12.5	11.5	10.9				
860	CFM			4837	4587	4346	4093	3815	3084						
	BHP			0.71	0.73	0.74	0.75	0.75	0.73						
	Sones			15.8	15.7	14.9	14.4	13	12						
875	CFM	4922	4676	4439	4192	3922	3240								
	BHP	0.75	0.77	0.78	0.79	0.79	0.78								
	Sones	16.4	16.4	15.6	15.1	13.7	12.6								
1	960	CFM	5400	5176	4958	4742	4508	3985	3169						
		BHP	0.98	1.01	1.03	1.04	1.04	1.04	1.00						
		Sones	18.9	18.6	18	17.4	16.7	15.2	14.7						
1 1/2	VG-2	1030	CFM	5793	5585	5380	5179	4968	4503	3917	2972				
			BHP	1.22	1.24	1.26	1.28	1.29	1.29	1.27	1.18				
			Sones	21	21	20	19.7	19.2	17.8	16.6	17.1				
		1100	CFM	6187	5992	5798	5610	5421	5006	4529	3861				
			BHP	1.48	1.51	1.53	1.55	1.57	1.57	1.57	1.53				
			Sones	24	23	23	22	22	21	19.7	18.9				
2	B-2	1140	CFM	6412	6224	6036	5855	5674	5283	4837	4276	3445			
			BHP	1.65	1.67	1.7	1.72	1.74	1.74	1.74	1.73	1.63			
			Sones	25	24	24	23	22	22	21	19.6	20			
	VG-3	1210	CFM	6806	6628	6451	6279	6108	5748	5350	4892	4289	3365		
			BHP	1.97	2	2.03	2.05	2.07	2.09	2.09	2.08	2.04	1.88		
			Sones	24	24	23	23	23	22	21	20	20	21		

MAXIMUM BHP AT A
GIVEN RPM = (RPM/946)³
MAXIMUM RPM = 1210
TIP SPEED (ft/min) = RPM x 5.595
MAXIMUM MOTOR FRAME SIZE = 184T
AVERAGE DISCHARGE VELOCITY
(FPM) = CFM/2.92

Performance certified is for installation type A: Free inlet, Free outlet. Power rating (BHP) does not include transmission losses. Performance ratings do not include the effects of appurtenances (accessories). The sound ratings shown are loudness values in fan sones at 5 ft. (1.5 m) in a hemispherical free field calculated per AMCA Standard 301. Values shown are for installation type A: Free inlet hemispherical sone levels.

Roof Upblast/Sidewall Exhaust

Size-200HP: CUBE • CUE • USGF

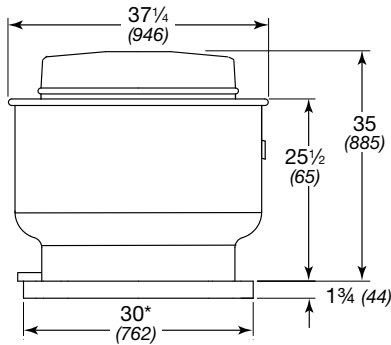

All dimensions in inches (millimeters), weight in pounds (kilograms).
 ^Weight shown is largest cataloged open drip-proof motor.

With Standard Curb Cap*	CUBE	CUE	USGF
^Approximate Weight	142 (64)	145 (66)	213 (97)
Damper Size	24 x 24 (610 x 610)		N/A
Roof/Wall (without wall bracket) Opening	26 1/2 x 26 1/2 (673 x 673)		
Wall Opening with Wall Bracket	26 x 26 (660 x 660)	N/A	
Wall Opening with a Curb Through Wall	30 x 30 (762 x 762)	N/A	

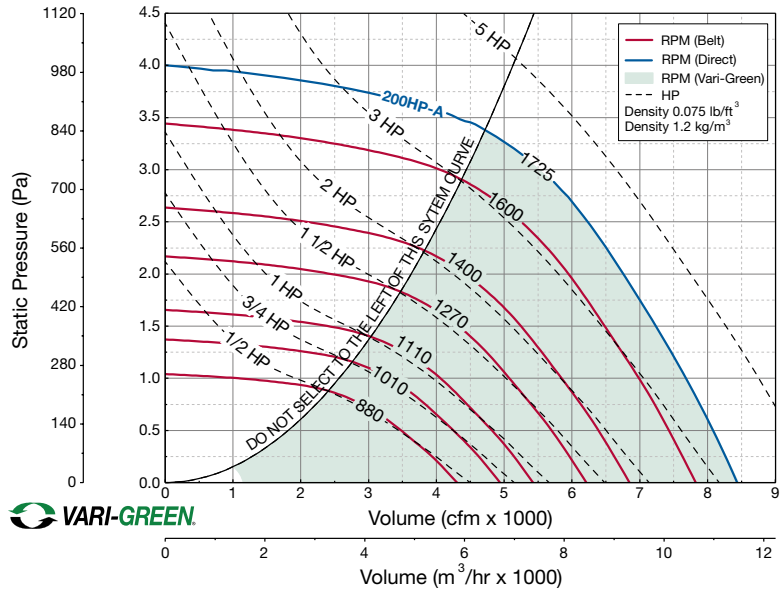

Motor HP		Fan RPM	Static Pressure in Inches wg										
Belt	Direct		0.5	0.75	1	1.25	1.5	1.75	2	2.25	2.5	2.75	
200HP													
1/2	VG-2	740	CFM	2024									
			BHP	0.31									
1/2	VG-2	880	Sones	8.2									
			CFM	2779	2317								
3/4	VG-2	945	BHP	0.62	0.64	0.62							
			Sones	12.3	11.7	10.8							
3/4	VG-2	1010	CFM	3397	3067	2637							
			BHP	0.75	0.78	0.79							
1	VG-2	1110	Sones	14.7	14.1	13.5							
			CFM	3851	3561	3242	2806						
1	VG-2	1110	BHP	0.98	1.02	1.04	1.04						
			Sones	17.1	16.5	16	15.8						
1 1/2	VG-2	1190	CFM	4207	3944	3661	3321	2850					
			BHP	1.2	1.24	1.27	1.29	1.26					
1 1/2	VG-2	1190	Sones	19.4	18.5	17.9	17.5	17.9					
			CFM	4558	4312	4055	3789	3433	2944				
1 1/2	VG-2	1270	BHP	1.44	1.49	1.53	1.56	1.56	1.53				
			Sones	22	21	21	20	19.3	20				
2	VG-2	1335	CFM	4837	4606	4369	4116	3826	3482	2946			
			BHP	1.67	1.71	1.76	1.79	1.82	1.82	1.75			
2	VG-2	1335	Sones	23	23	22	21	21	21	22			
			CFM	5110	4898	4674	4436	4195	3880	3515	2982		
2	VG-3	1400	BHP	1.91	1.96	2.01	2.05	2.09	2.09	2.08	2.01		
			Sones	25	24	24	23	22	23	23	24		
3	VG-5	1600	CFM	5943	5775	5581	5385	5182	4971	4760	4476	4189	3760
			BHP	2.81	2.88	2.93	2.99	3.03	3.08	3.13	3.13	3.13	3.06
3	VG-5	1600	Sones	29	27	28	28	28	26	26	28	30	31
			CFM	6457	6302	6135	5954	5772	5582	5386	5190	4948	4682
A-5	VG-5	1725	BHP	3.50	3.57	3.64	3.69	3.75	3.80	3.85	3.90	3.92	3.92
			Sones	33	30	30	31	32	32	30	28	31	35

MAXIMUM BHP AT A
 GIVEN RPM = (RPM/1093)³
 MAXIMUM RPM = 1725
 TIP SPEED (ft/min) = RPM x 5.595
 MAXIMUM MOTOR FRAME SIZE = 184T
 AVERAGE DISCHARGE VELOCITY
 (FPM) = CFM/2.92

Performance certified is for installation type A: Free inlet, Free outlet. Power rating (BHP) does not include transmission losses. Performance ratings do not include the effects of appurtenances (accessories). The sound ratings shown are loudness values in fan sones at 5 ft. (1.5 m) in a hemispherical free field calculated per AMCA Standard 301. Values shown are for installation type A: Free inlet hemispherical sone levels.

Roof Upblast/Sidewall Exhaust Size-220: CUBE

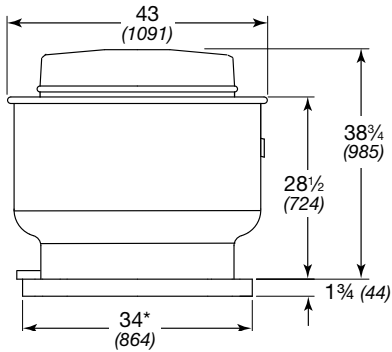

All dimensions in inches (millimeters), weight in pounds (kilograms).
^Weight shown is largest cataloged open drip-proof motor.

With Standard Curb Cap*		CUBE
^Approximate Weight		174 (79)
Damper Size		24 x 24 (610 x 610)
Roof/Wall (without wall bracket) Opening		30½ x 30½ (775 x 775)
Wall Opening with Wall Bracket		30 x 30 (762 x 762)
Wall Opening with a Curb Through Wall		34 x 34 (864 x 864)

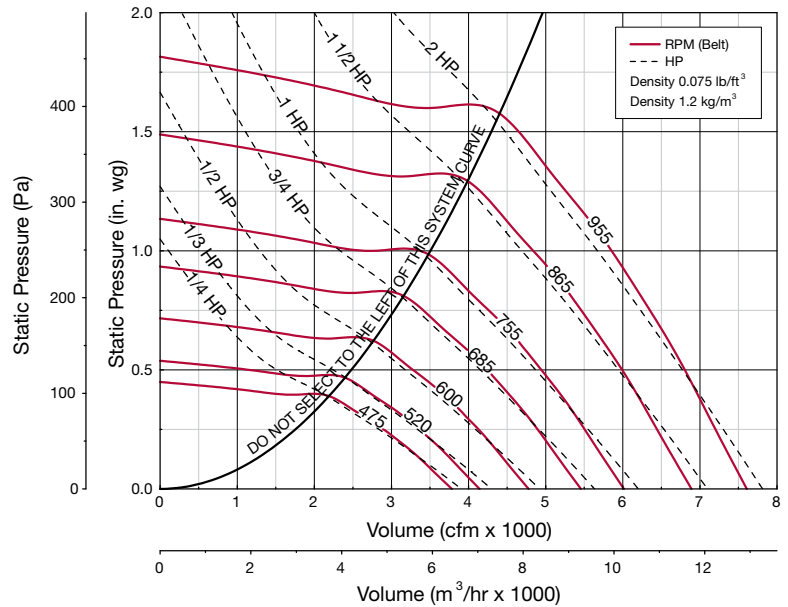

Motor HP	Fan RPM	Static Pressure in Inches wg										
		0	0.125	0.25	0.375	0.5	0.625	0.75	1	1.25	1.5	
220												
1/4	450	CFM	3585	3155	2624							
		BHP	0.19	0.21	0.22							
		Sones	7.4	6.8	6.2							
	475	CFM	3784	3377	2896	2268						
		BHP	0.23	0.25	0.26	0.25						
		Sones	8	7.3	6.7	6.2						
1/3	520	CFM	4142	3771	3357	2845						
		BHP	0.3	0.32	0.34	0.34						
		Sones	9.3	8.5	7.7	7.2						
1/2	600	CFM	4779	4457	4124	3736	3279					
		BHP	0.46	0.48	0.51	0.52	0.52					
		Sones	12	11.1	10.2	9.5	8.9					
3/4	645	CFM	5138	4838	4539	4194	3811	3346				
		BHP	0.57	0.6	0.63	0.64	0.65	0.64				
		Sones	13.6	12.7	12	11.3	10.6	10				
	685	CFM	5457	5174	4893	4581	4234	3836	3383			
		BHP	0.68	0.71	0.74	0.76	0.78	0.78	0.77			
		Sones	15	14.2	13.7	13.2	12.3	11.7	11.2			
1	755	CFM	6014	5758	5502	5239	4944	4620	4258			
		BHP	0.91	0.94	0.98	1.01	1.03	1.04	1.04			
		Sones	17.7	17	16.6	16.3	15.8	14.9	14.4			
1½	810	CFM	6452	6213	5975	5737	5470	5185	4883	4156		
		BHP	1.13	1.16	1.2	1.24	1.26	1.28	1.29	1.27		
		Sones	19	18.5	17.9	17.6	17.2	16.5	15.7	14.8		
	865	CFM	6890	6667	6443	6220	5987	5729	5453	4835	4111	
		BHP	1.37	1.41	1.45	1.49	1.52	1.54	1.56	1.57	1.53	
		Sones	21	20	19.6	19.2	18.7	18.1	17.4	16.5	16.1	
2	910	CFM	7249	7036	6823	6612	6400	6158	5909	5365	4704	
		BHP	1.6	1.64	1.68	1.72	1.76	1.78	1.81	1.83	1.81	
		Sones	23	22	22	21	21	20	19.3	18.3	17.4	
	955	CFM	7607	7405	7202	7000	6799	6580	6347	5844	5261	4602
		BHP	1.85	1.89	1.93	1.97	2.02	2.05	2.07	2.11	2.11	2.07
		Sones	25	25	24	24	23	23	22	20	19.4	18.9

MAXIMUM BHP AT A GIVEN RPM = (RPM/743)³
 MAXIMUM RPM = 955
 TIP SPEED (ft/min) = RPM x 6.413
 MAXIMUM MOTOR FRAME SIZE = 184T
 AVERAGE DISCHARGE VELOCITY (FPM) = CFM/3.76

Performance certified is for installation type A: Free inlet, Free outlet. Power rating (BHP) does not include transmission losses. Performance ratings do not include the effects of appurtenances (accessories). The sound ratings shown are loudness values in fan sones at 5 ft. (1.5 m) in a hemispherical free field calculated per AMCA Standard 301. Values shown are for installation type A: Free inlet hemispherical sone levels.

Roof Upblast/Sidewall Exhaust Size-220HP: CUBE

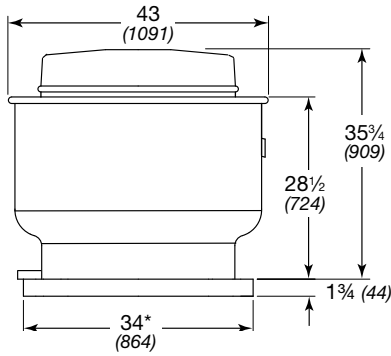

All dimensions in inches (millimeters), weight in pounds (kilograms).
^Weight shown is largest cataloged open drip-proof motor.

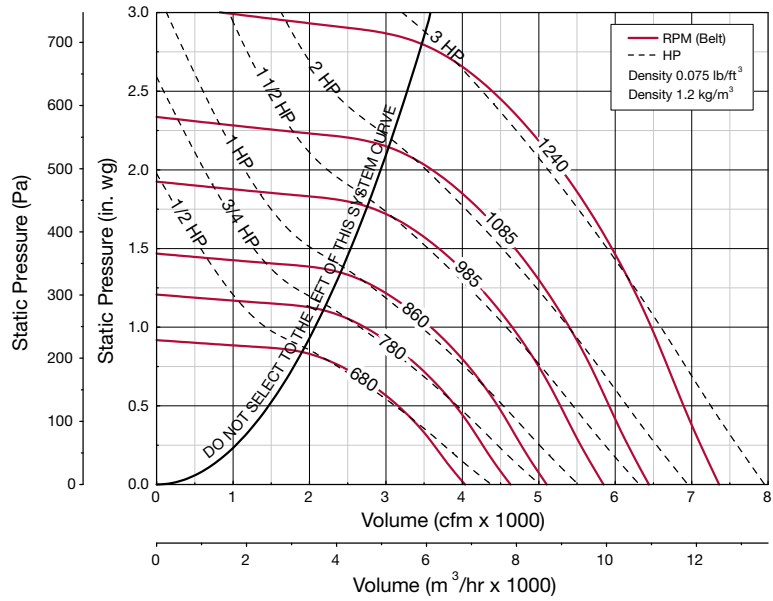

With Standard Curb Cap*	CUBE
^Approximate Weight	174 (79)
Damper Size	24 x 24 (610 x 610)
Roof/Wall (without a wall bracket) Opening	30½ x 30½ (775 x 775)
Wall Opening with Wall Bracket	30 x 30 (762 x 762)
Wall Opening with a Curb Through Wall	34 x 34 (864 x 864)

Motor HP	Fan RPM	Static Pressure in Inches wg											
		0.5	0.75	1	1.25	1.5	1.75	2	2.25	2.5	2.75		
220HP													
1/2	650	CFM	2909	1940									
		BHP	0.45	0.42									
		Sones	8.7	7.7									
	680	CFM	3151	2405									
		BHP	0.51	0.51									
		Sones	9.7	8.7									
3/4	735	CFM	3582	3006									
		BHP	0.63	0.65									
		Sones	11.9	11									
	780	CFM	3902	3427	2716								
		BHP	0.74	0.78	0.77								
		Sones	13.4	12.5	12.1								
1	860	CFM	4459	4075	3578	2863							
		BHP	0.96	1.02	1.05	1.01							
		Sones	15	14.3	13.9	13.2							
1½	985	CFM	5281	4988	4642	4220	3674	2825					
		BHP	1.39	1.48	1.54	1.57	1.56	1.46					
		Sones	19.1	17.9	17.4	17.1	16.5	14.9					
2	1035	CFM	5602	5335	5033	4659	4209	3630					
		BHP	1.6	1.69	1.77	1.81	1.82	1.79					
		Sones	21	19.8	18.9	18.7	18.3	17.3					
	1085	CFM	5920	5678	5390	5061	4679	4210	3573				
		BHP	1.82	1.92	2	2.06	2.1	2.09	2.03				
		Sones	23	22	20	20	20	19.6	18.1				
3	1135	CFM	6236	6006	5743	5456	5114	4708	4215	3518			
		BHP	2.06	2.17	2.26	2.34	2.39	2.4	2.38	2.28			
		Sones	24	23	22	22	21	21	21	19.5			
	1188	CFM	6570	6350	6111	5848	5540	5202	4792	4286	3563		
		BHP	2.34	2.46	2.56	2.65	2.71	2.75	2.76	2.72	2.59		
		Sones	25	25	24	24	23	23	22	22	22		
	1240	CFM	6895	6684	6469	6217	5950	5637	5283	4885	4374	3633	
		BHP	2.64	2.76	2.88	2.97	3.05	3.1	3.13	3.13	3.08	2.92	
		Sones	27	26	26	25	25	24	24	24	24	26	

MAXIMUM BHP AT A GIVEN RPM = (RPM/847)³
 MAXIMUM RPM = 1240
 TIP SPEED (ft/min) = RPM x 6.413
 MAXIMUM MOTOR FRAME SIZE = 184T
 AVERAGE DISCHARGE VELOCITY (FPM) = CFM/3.76

Performance certified is for installation type A: Free inlet, Free outlet. Power rating (BHP) does not include transmission losses. Performance ratings do not include the effects of appurtenances (accessories). The sound ratings shown are loudness values in fan sones at 5 ft. (1.5 m) in a hemispherical free field calculated per AMCA Standard 301. Values shown are for installation type A: Free inlet hemispherical sone levels.

Roof Upblast/Sidewall Exhaust Size-240: CUBE • CUE

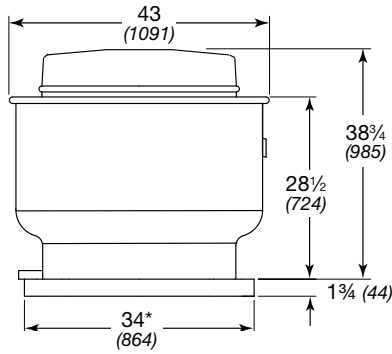

All dimensions in inches (millimeters), weight in pounds (kilograms).
 ^Weight shown is largest cataloged open drip-proof motor.

With Standard Curb Cap*	CUBE	CUE
^Approximate Weight	142 (64)	226 (103)
Damper Size	24 x 24 (610 x 610)	
Roof/Wall (without wall bracket) Opening	30 1/2 x 30 1/2 (775 x 775)	
Wall Opening with Wall Bracket	30 x 30 (762 x 762)	N/A
Wall Opening with a Curb Through Wall	34 x 34 (864 x 864)	N/A

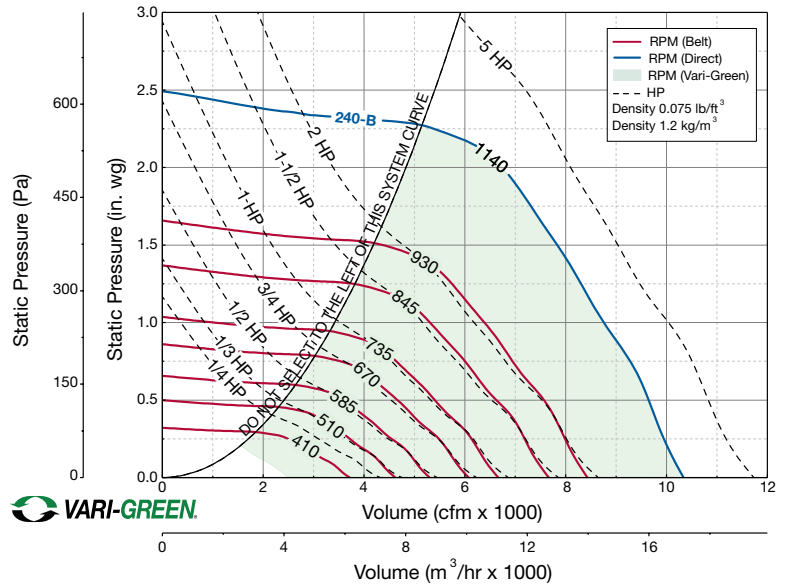

Motor HP		Fan RPM	Static Pressure in Inches wg										
Belt	Direct		0	0.125	0.25	0.375	0.5	0.625	0.75	1	1.25	1.5	
240													
1/4	VARI-GREEN VG-2	410	CFM	3717	3170	2471							
			BHP	0.16	0.18	0.18							
Sones			6.4	5.8	5.3								
1/3		510	CFM	4623	4243	3717	3134						
			BHP	0.31	0.33	0.34	0.34						
			Sones	8.9	8.1	7.3	6.9						
1/2		585	CFM	5303	4961	4540	4093	3565					
			BHP	0.46	0.49	0.51	0.52	0.51					
			Sones	11.5	10.5	9.5	8.8	8.4					
3/4		628	CFM	5693	5368	5010	4590	4141	3600				
	BHP		0.57	0.61	0.63	0.64	0.65	0.63					
	Sones		12.9	11.9	11.1	10.4	9.8	9.4					
	670		CFM	6074	5763	5461	5052	4659	4202	3524			
			BHP	0.69	0.74	0.76	0.78	0.79	0.78	0.73			
			Sones	14.3	13.4	12.8	12.2	11.5	11.0	10.6			
1	735	CFM	6663	6370	6133	5764	5409	5037	4618				
		BHP	0.92	0.97	0.99	1.01	1.03	1.04	1.03				
		Sones	16.6	15.9	15.5	15.1	14.6	13.9	13.4				
1 1/2	790	CFM	7162	6883	6661	6361	6011	5693	5332	4453			
		BHP	1.14	1.20	1.22	1.25	1.27	1.28	1.29	1.24			
		Sones	18.2	17.5	17.2	16.8	16.3	15.7	15.0	14.3			
		845	CFM	7660	7400	7184	6947	6615	6304	6002	5282		
			BHP	1.39	1.46	1.49	1.51	1.54	1.56	1.57	1.56		
			Sones	19.6	19.0	18.6	18.2	17.6	17.0	16.4	15.4		
2	C-2	860	CFM	7796	7540	7326	7106	6779	6468	6176	5483	4363	
			BHP	1.47	1.54	1.57	1.59	1.62	1.64	1.66	1.65	1.52	
			Sones	20	19.8	19.4	19.0	18.4	17.8	17.2	16.2	15.9	
	VG-3	930	CFM	8431	8194	7985	7798	7536	7233	6953	6375	5706	4324
			BHP	1.86	1.93	1.98	2.00	2.03	2.06	2.08	2.10	2.07	1.83
			Sones	24	23	23	22	22	21	19.9	18.7	17.8	17.9
VG-5 B-5	1140	CFM	10335	10142	9948	9789	9637	9484	9240	8747	8306	7820	
		BHP	3.42	3.51	3.60	3.64	3.67	3.70	3.74	3.81	3.85	3.87	
		Sones	40	40	40	41	40	39	37	33	30	29	

MAXIMUM BHP AT A
 GIVEN RPM = (RPM/725)³
 MAXIMUM RPM = 1140
 TIP SPEED (ft/min) = RPM x 6.413
 MAXIMUM MOTOR FRAME SIZE = 184T
 AVERAGE DISCHARGE VELOCITY
 (FPM) = CFM/3.76

Performance certified is for installation type A: Free inlet, Free outlet. Power rating (BHP) does not include transmission losses. Performance ratings do not include the effects of appurtenances (accessories). The sound ratings shown are loudness values in fan sones at 5 ft. (1.5 m) in a hemispherical free field calculated per AMCA Standard 301. Values shown are for installation type A: Free inlet hemispherical sone levels.

Roof Upblast/Sidewall Exhaust Size-240HP: CUBE • CUE

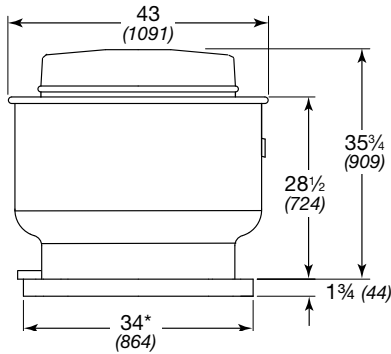

All dimensions in inches (millimeters), weight in pounds (kilograms).
 ^Weight shown is largest cataloged open drip-proof motor.

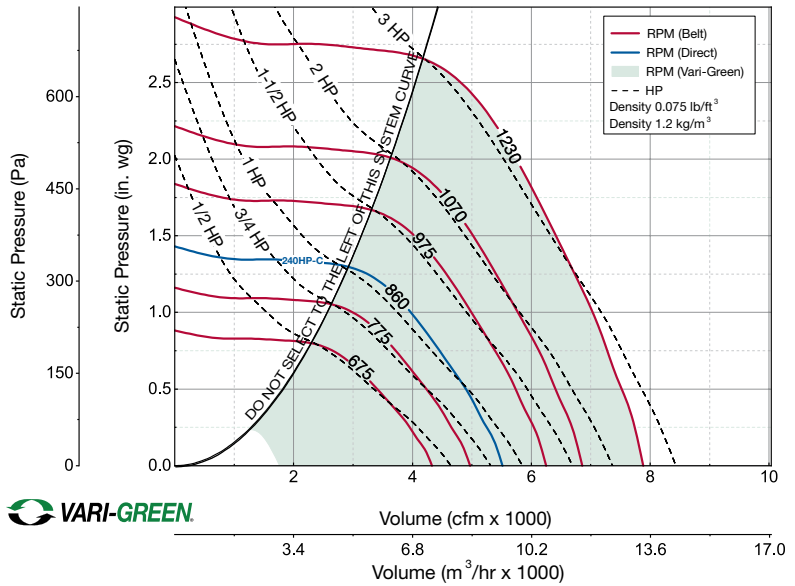

With Standard Curb Cap*	CUBE	CUE
^Approximate Weight	175 (79)	209 (95)
Damper Size	24 x 24 (610 x 610)	
Roof/Wall (without wall bracket) Opening	30½ x 30½ (775 x 775)	
Wall Opening with Wall Bracket	30 x 30 (762 x 762)	N/A
Wall Opening with a Curb Through Wall	34 x 34 (864 x 864)	N/A



Motor HP		Fan RPM	Static Pressure in Inches wg											
Belt	Direct		0.5	0.625	0.75	1	1.25	1.5	1.75	2	2.25	2.5		
240HP														
1/2	VG-1	635	CFM	3046	2673									
			BHP	0.43	0.43									
		675	Sones	8.1	7.4									
			CFM	3405	3070	2607								
		725	BHP	0.51	0.52	0.51								
			Sones	9.4	8.8	8.4								
3/4	VARI-GREEN	725	CFM	3824	3547	3222								
			BHP	0.62	0.64	0.65								
		775	Sones	11.3	10.7	10.3								
			CFM	4233	3979	3704	2940							
		860	BHP	0.75	0.77	0.78	0.77							
			Sones	13.1	12.5	12.1	11.8							
1	C-1	860	CFM	4888	4680	4451	3943	3185						
			BHP	0.99	1.02	1.05	1.07	1.05						
		913	Sones	15.0	14.5	14.3	13.9	13.2						
			CFM	5286	5094	4890	4448	3932						
		975	BHP	1.16	1.20	1.23	1.28	1.29						
			Sones	16.4	15.8	15.4	15.2	14.7						
2	VG-3	1023	CFM	5737	5567	5387	4988	4539	4006					
			BHP	1.39	1.43	1.48	1.53	1.56	1.56					
		1070	Sones	18.4	17.9	17.3	16.9	16.6	15.9					
			CFM	6075	5927	5756	5389	4995	4533	3854				
		1140	BHP	1.59	1.63	1.68	1.75	1.80	1.81	1.77				
			Sones	20	19.6	19.0	18.3	18.1	17.7	16.4				
3	B-3	1140	CFM	6404	6272	6112	5775	5407	4990	4550	3625			
			BHP	1.80	1.84	1.89	1.98	2.04	2.07	2.08	1.95			
		1230	Sones	22	22	21	19.7	19.7	19.4	18.8	16.6			
			CFM	6891	6766	6637	6329	5994	5649	5239	4825	4052		
		1230	BHP	2.16	2.20	2.25	2.35	2.42	2.49	2.50	2.52	2.41		
			Sones	24	24	23	22	22	22	21	21	19.8		
1230	CFM	7513	7395	7280	7016	6730	6410	6090	5709	5326	4722			
	BHP	2.68	2.73	2.77	2.88	2.98	3.05	3.13	3.14	3.16	3.09			
1230	Sones	26	25	25	25	25	24	24	23	23	25			

MAXIMUM BHP AT A GIVEN RPM = (RPM/837)³
 MAXIMUM RPM = 1230
 TIP SPEED (ft/min) = RPM x 6.413
 MAXIMUM MOTOR FRAME SIZE = 184T
 AVERAGE DISCHARGE VELOCITY (FPM) = CFM/3.76

Performance certified is for installation type A: Free inlet, Free outlet. Power rating (BHP) does not include transmission losses. Performance ratings do not include the effects of appurtenances (accessories). The sound ratings shown are loudness values in fan sones at 5 ft. (1.5 m) in a hemispherical free field calculated per AMCA Standard 301. Values shown are for installation type A: Free inlet hemispherical sone levels.

Roof Upblast/Sidewall Exhaust Size-240XP: CUBE

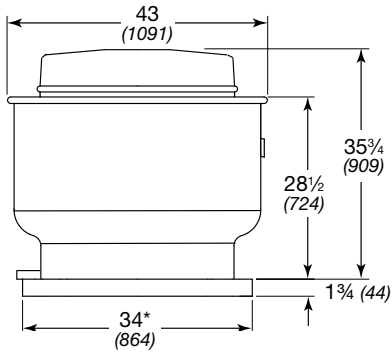

All dimensions in inches (millimeters), weight in pounds (kilograms).
^Weight shown is largest cataloged open drip-proof motor.

With Standard Curb Cap*	CUBE
^Approximate Weight	175 (79)
Damper Size	24 x 24 (610 x 610)
Roof/Wall (without wall bracket) Opening	30 1/2 x 30 1/2 (775 x 775)
Wall Opening with Wall Bracket	30 x 30 (762 x 762)
Wall Opening with a Curb Through Wall	34 x 34 (864 x 864)

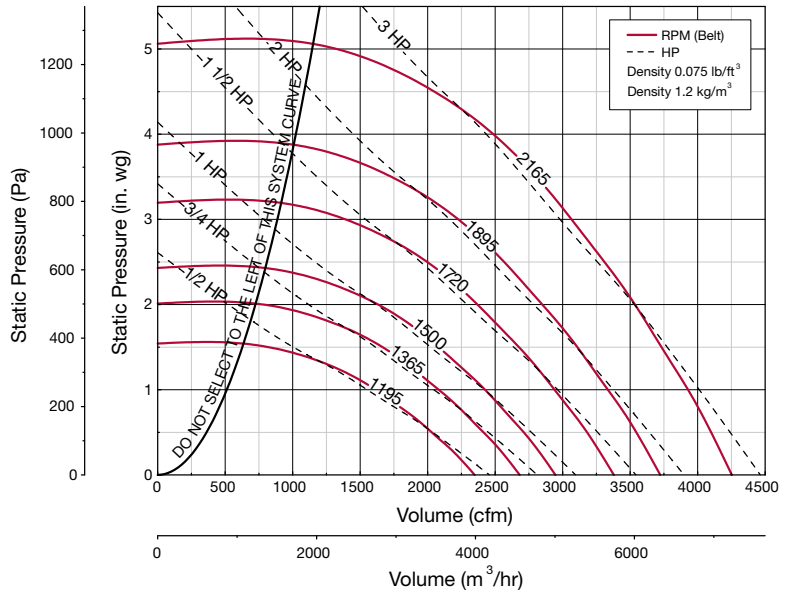

Motor HP	Fan RPM	Static Pressure in Inches wg										
		1	1.25	1.5	2	2.5	3	3.5	4	4.5	5	
240XP												
1/2	1100	CFM	1292	789								
		BHP	0.40	0.34								
		Sones	10.9	11.9								
	1195	CFM	1613	1321	792							
		BHP	0.53	0.51	0.43							
		Sones	11.6	12.1	13.4							
3/4	1365	CFM	2079	1886	1645							
		BHP	0.77	0.78	0.77							
		Sones	13.6	13.4	13.7							
	1421	CFM	2223	2042	1837	1209						
		BHP	0.86	0.88	0.88	0.79						
		Sones	14.4	14.2	14.2	15.3						
1	1500	CFM	2424	2256	2079	1630						
		BHP	1.00	1.03	1.04	1.01						
		Sones	15.9	15.3	15.1	15.5						
	1635	CFM	2743	2604	2450	2101	1631					
		BHP	1.28	1.31	1.33	1.34	1.28					
		Sones	18.6	18.0	17.5	17.0	17.7					
1 1/2	1720	CFM	2939	2815	2671	2366	1975	1336				
		BHP	1.48	1.51	1.53	1.57	1.53	1.35				
		Sones	21	19.8	19.2	18.4	18.4	20				
	1895	CFM	3333	3222	3109	2847	2566	2202	1706			
		BHP	1.94	1.98	2.01	2.07	2.10	2.05	1.92			
		Sones	24	23	22	21	21	21	22			
3	1956	CFM	3469	3361	3252	3006	2739	2414	2032	1326		
		BHP	2.13	2.16	2.20	2.26	2.30	2.28	2.21	1.89		
		Sones	25	24	23	22	22	21	22	25		
	2030	CFM	3632	3529	3423	3197	2945	2667	2319	1852		
		BHP	2.37	2.40	2.44	2.51	2.56	2.58	2.51	2.38		
		Sones	26	25	25	24	23	23	23	25		
	2165	CFM	3927	3830	3733	3535	3305	3063	2787	2461	2048	
		BHP	2.85	2.89	2.93	3.01	3.07	3.12	3.11	3.05	2.93	1324
		Sones	29	28	28	27	26	25	25	25	27	31

MAXIMUM BHP AT A GIVEN RPM = (RPM/1478)³
 MAXIMUM RPM = 2165
 TIP SPEED (ft/min) = RPM x 4.778
 MAXIMUM MOTOR FRAME SIZE = 184T
 AVERAGE DISCHARGE VELOCITY (FPM) = CFM/3.76

Performance certified is for installation type A: Free inlet, Free outlet. Power rating (BHP) does not include transmission losses. Performance ratings do not include the effects of appurtenances (accessories). The sound ratings shown are loudness values in fan sones at 5 ft. (1.5 m) in a hemispherical free field calculated per AMCA Standard 301. Values shown are for installation type A: Free inlet hemispherical sone levels.

Roof Upblast/Sidewall Exhaust Size-300: CUBE • CUE

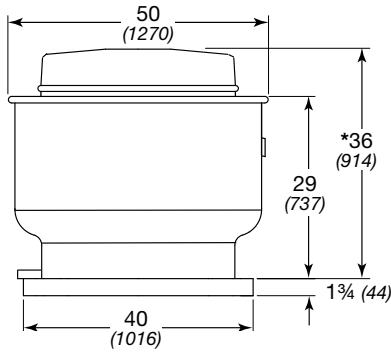

All dimensions in inches (millimeters), weight in pounds (kilograms).
 * May be greater depending on motor.
 ^Weight shown is largest cataloged open drip-proof motor.

	CUBE	CUE
^Approximate Weight	313 (142)	380 (172)
Damper Size	34 x 34 (864 x 864)	
Roof/Wall (without wall bracket) Opening	36 1/2 x 36 1/2 (927 x 927)	
Wall Opening with Wall Bracket	36 x 36 (914 x 914)	
Wall Opening with a Curb Through Wall	40 x 40 (1016 x 1016)	N/A

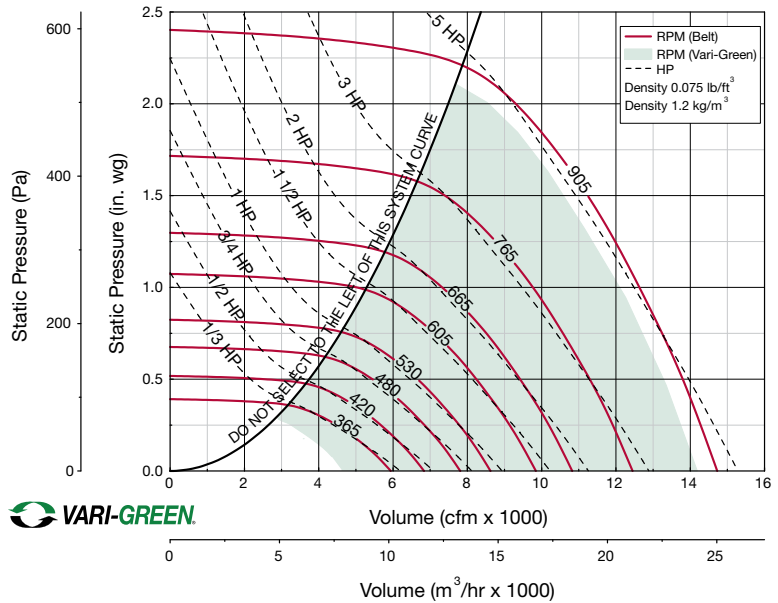

Motor HP		Fan RPM	Static Pressure in Inches wg											
Belt	Direct		0	0.125	0.25	0.5	0.75	1	1.25	1.5	1.75	2		
300														
1/3	VG-5	355	CFM	5777	5132	4227								
			BHP	0.27	0.30	0.31								
			Sones	6.9	6.3	5.3								
			CFM	5940	5316	4464								
			BHP	0.29	0.33	0.34								
			Sones	7.2	6.5	5.7								
		1/2	VG-5	420	CFM	6835	6314	5660						
					BHP	0.45	0.49	0.52						
					Sones	9.0	8.2	7.5						
				480	CFM	7811	7377	6844	5440					
					BHP	0.67	0.72	0.76	0.77					
					Sones	11.0	10.5	9.9	8.5					
1	VG-5	530	CFM	8625	8231	7772	6636							
			BHP	0.90	0.95	1.00	1.05							
			Sones	13.3	12.7	12.2	11.2							
1 1/2	VG-5	605	CFM	9845	9501	9127	8226	7084						
			BHP	1.34	1.40	1.46	1.54	1.55						
			Sones	17.0	16.4	15.7	14.8	13.5						
2	VG-5	665	CFM	10822	10508	10193	9411	8495	7271					
			BHP	1.77	1.85	1.92	2.02	2.07	2.04					
			Sones	20	19.7	18.6	17.5	16.7	15.1					
3	VG-5	765	CFM	12449	12176	11904	11273	10554	9743	8756	7352			
			BHP	2.70	2.78	2.86	3.00	3.09	3.15	3.14	2.98			
			Sones	24	24	23	22	21	20	18.7	17			
5	VG-5	795	CFM	12937	12675	12413	11818	11145	10404	9479	8302			
			BHP	3.03	3.12	3.20	3.35	3.46	3.53	3.53	3.43			
			Sones	26	25	24	23	22	22	21	18.5			
	C-5	860	CFM	13995	13753	13510	12987	12392	11721	11002	10124	9007		
			BHP	3.84	3.93	4.02	4.19	4.33	4.41	4.47	4.46	4.34		
			Sones	30	30	29	27	26	26	24	23	21		
X	X	905	CFM	14727	14497	14266	13788	13223	12614	11963	11191	10357	9178	
			BHP	4.47	4.57	4.67	4.85	5.00	5.11	5.19	5.21	5.20	5.01	
			Sones	32	32	32	29	28	28	27	26	24	22	

MAXIMUM BHP AT A GIVEN RPM = (RPM/522)³
 MAXIMUM RPM = 905
 TIP SPEED (ft/min) = RPM x 7.983
 MAXIMUM MOTOR FRAME SIZE = 213T
 AVERAGE DISCHARGE VELOCITY (FPM) = CFM/5.50

Performance certified is for installation type A: Free inlet, Free outlet. Power rating (BHP) does not include transmission losses. Performance ratings do not include the effects of appurtenances (accessories). The sound ratings shown are loudness values in fan sones at 5 ft. (1.5 m) in a hemispherical free field calculated per AMCA Standard 301. Values shown are for installation type A: Free inlet hemispherical sone levels.

Roof Upblast/Sidewall Exhaust Size-300HP: CUBE • CUE

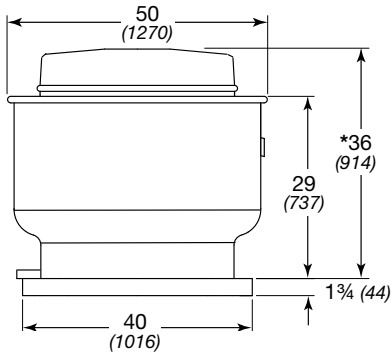

All dimensions in inches (millimeters), weight in pounds (kilograms).
 * May be greater depending on motor.
 ^Weight shown is largest cataloged open drip-proof motor.

	CUBE	CUE
^Approximate Weight	313 (142)	434 (197)
Damper Size	34 x 34 (864 x 864)	
Roof/Wall (without wall bracket) Opening	36 1/2 x 36 1/2 (927 x 927)	
Wall Opening with Wall Bracket	36 x 36 (914 x 914)	
Wall Opening with a Curb Through Wall	40 x 40 (1016 x 1016)	N/A

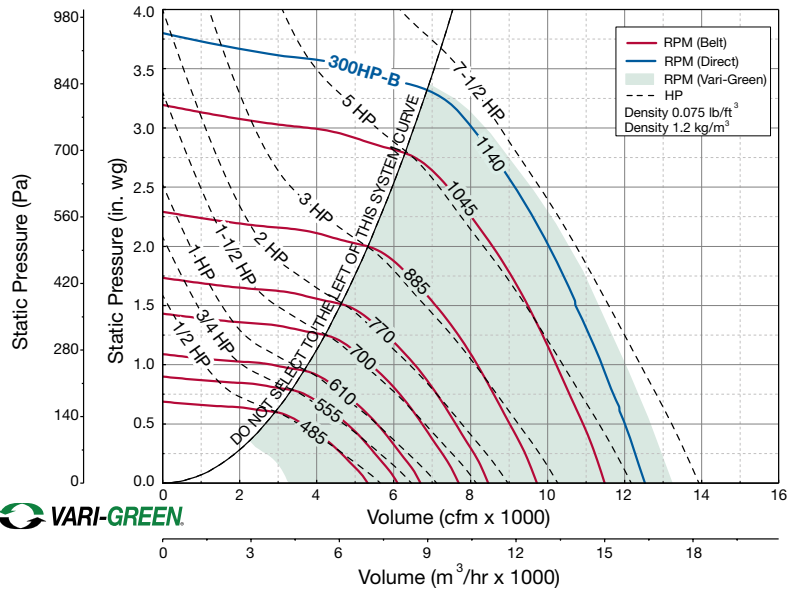

Motor HP		Fan RPM	Static Pressure in Inches wg										
Belt	Direct		0.5	0.75	1	1.25	1.5	1.75	2	2.25	2.5	2.75	
300HP													
1/2	VG-3	460	CFM	3125									
			BHP	0.44									
3/4	VG-3	555	CFM	4788	3651								
			BHP	0.77	0.76								
1	VG-3	610	CFM	5549	4731								
			BHP	1.00	1.03								
1 1/2	VG-3	700	CFM	6741	6149	5390							
			BHP	1.47	1.53	1.57							
2	VG-3	770	CFM	7613	7107	6535	5814	4684					
			BHP	1.91	2.00	2.06	2.09	1.99					
3	C-3	860	CFM	8712	8289	7812	7292	6647	5834				
			BHP	2.61	2.72	2.80	2.87	2.90	2.85				
5	VG-7 1/2	991	CFM	10275	9913	9546	9133	8711	8201	7641	6946		
			BHP	3.90	4.03	4.16	4.26	4.35	4.41	4.44	4.39		
5	VG-7 1/2	1045	CFM	10909	10570	10222	9855	9455	9054	8533	8002	7330	6463
			BHP	4.54	4.68	4.82	4.94	5.04	5.13	5.17	5.21	5.15	4.99
5	B-7 1/2	1140	CFM	12016	11713	11394	11075	10733	10366	9999	9562	9075	8586
			BHP	5.83	6.00	6.14	6.29	6.42	6.52	6.63	6.70	6.74	6.77
			Sones	46	47	46	44	42	40	40	40	40	38

MAXIMUM BHP AT A GIVEN RPM = (RPM/602)³
 MAXIMUM RPM = 1140
 TIP SPEED (ft/min) = RPM x 7.983
 MAXIMUM MOTOR FRAME SIZE = 213T
 AVERAGE DISCHARGE VELOCITY (FPM) = CFM/5.50

Performance certified is for installation type A: Free inlet, Free outlet. Power rating (BHP) does not include transmission losses. Performance ratings do not include the effects of appurtenances (accessories). The sound ratings shown are loudness values in fan sones at 5 ft. (1.5 m) in a hemispherical free field calculated per AMCA Standard 301. Values shown are for installation type A: Free inlet hemispherical sone levels.

Roof Upblast/Sidewall Exhaust Size-300XP: CUBE

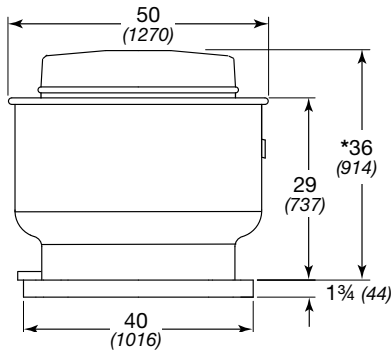

All dimensions in inches (millimeters), weight in pounds (kilograms).
 * May be greater depending on motor.
 ^Weight shown is largest cataloged open drip-proof motor.

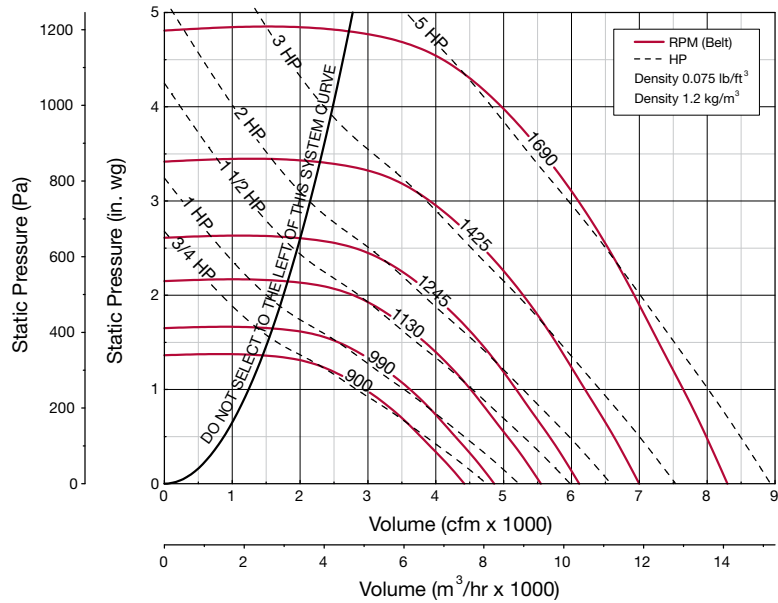

CUBE	
^Approximate Weight	313 (142)
Damper Size	34 x 34 (864 x 864)
Roof/Wall (without wall bracket) Opening	36 1/2 x 36 1/2 (927 x 927)
Wall Opening with Wall Bracket	36 x 36 (914 x 914)
Wall Opening with a Curb Through Wall	40 x 40 (1016 x 1016)

Motor HP	Fan RPM	Static Pressure in Inches wg										
		1	1.25	1.5	2	2.5	3	3.5	4	4.5	4.75	
300XP												
3/4	790	CFM	1776									
		BHP	0.48									
		Sones	9.4									
	900	CFM	2958	2273								
		BHP	0.79	0.75								
		Sones	12.2	11.3								
1	990	CFM	3619	3167	2538							
		BHP	1.04	1.05	1.00							
		Sones	14.6	13.4	12.8							
	1060	CFM	4073	3708	3255							
		BHP	1.25	1.28	1.28							
		Sones	16.5	15.3	14.4							
1 1/2	1130	CFM	4511	4201	3833	2773						
		BHP	1.48	1.53	1.56	1.46						
		Sones	18.9	17.8	16.8	15.6						
2	1245	CFM	5182	4930	4648	3943	2705					
		BHP	1.92	1.99	2.04	2.08	1.86					
		Sones	22	21	20	18.6	17.9					
	3	1335	CFM	5695	5465	5220	4648	3905				
			BHP	2.32	2.40	2.47	2.56	2.53				
			Sones	24	24	23	21	19.4				
3	1425	CFM	6199	5983	5768	5286	4695	3886				
		BHP	2.78	2.86	2.95	3.07	3.14	3.03				
		Sones	27	26	25	24	22	21				
5	1493	CFM	6574	6369	6164	5722	5200	4550	3646			
		BHP	3.16	3.25	3.34	3.49	3.58	3.57	3.37			
		Sones	29	28	28	26	24	23	22			
	1560	CFM	6941	6746	6549	6143	5684	5134	4441	3049		
		BHP	3.57	3.67	3.76	3.93	4.05	4.12	4.02	3.50		
		Sones	31	30	30	28	27	25	24	24		
	1690	CFM	7643	7464	7284	6920	6528	6091	5587	4951	4100	3070
		BHP	4.47	4.57	4.68	4.87	5.04	5.16	5.24	5.14	4.88	4.32
		Sones	36	35	34	33	31	30	29	28	28	28

MAXIMUM BHP AT A GIVEN RPM = (RPM/972)³
 MAXIMUM RPM = 1690
 TIP SPEED (ft/min) = RPM x 5.825
 MAXIMUM MOTOR FRAME SIZE = 213T
 AVERAGE DISCHARGE VELOCITY (FPM) = CFM/5.50

Performance certified is for installation type A: Free inlet, Free outlet. Power rating (BHP) does not include transmission losses. Performance ratings do not include the effects of appurtenances (accessories). The sound ratings shown are loudness values in fan sones at 5 ft. (1.5 m) in a hemispherical free field calculated per AMCA Standard 301. Values shown are for installation type A: Free inlet hemispherical sone levels.

Roof Upblast Exhaust Size-360: CUBE

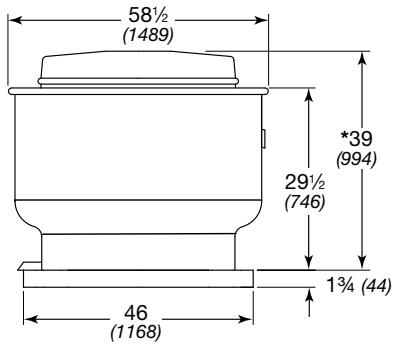

All dimensions in inches (millimeters), weight in pounds (kilograms).
 * May be greater depending on motor.
 ^Weight shown is largest cataloged open drip-proof motor.

CUBE	
^Approximate Weight	440 (200)
Damper Size	40 x 40 (1016 x 1016)
Roof Opening	42½ x 42½ (1080 x 1080)

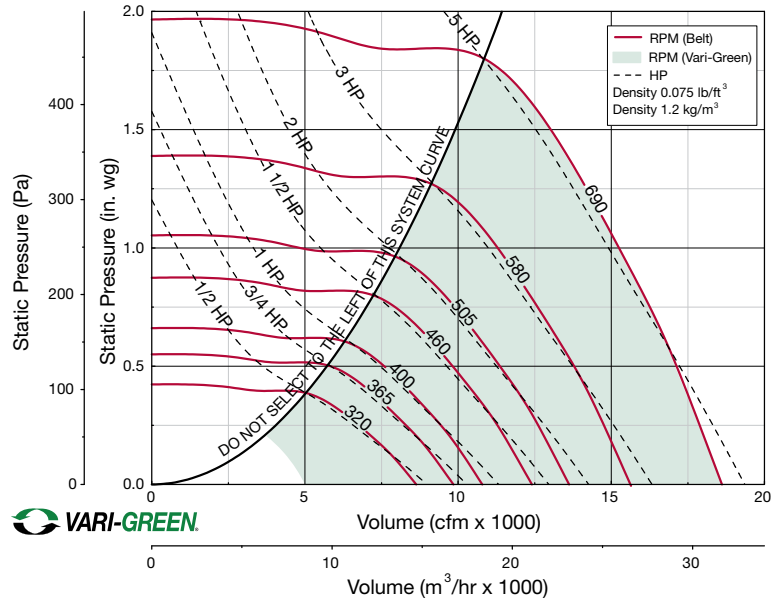

Motor HP	Fan RPM	Static Pressure in Inches wg											
		0	0.125	0.25	0.375	0.5	0.75	1	1.25	1.5	1.75		
360													
1/2	VG-1	300	CFM	8092	7206	6023							
			BHP	0.37	0.42	0.43							
			Sones	6.9	5.9	5.4							
		320	CFM	8631	7820	6755	5256						
			BHP	0.44	0.50	0.52	0.51						
			Sones	7.7	6.8	6.0	6.6						
3/4	365	CFM	9845	9142	8299	7286	5767						
		BHP	0.66	0.72	0.77	0.78	0.74						
		Sones	10.2	9.4	8.5	8.0	8.3						
1	400	CFM	10789	10153	9426	8556	7575						
		BHP	0.87	0.94	0.99	1.02	1.02						
		Sones	12.7	11.9	11.1	10.3	9.9						
1½	VG-2	460	CFM	12408	11862	11281	10587	9814	7809				
			BHP	1.32	1.40	1.48	1.53	1.55	1.52				
			Sones	16.8	16.5	15.8	15.1	14.5	13.5				
2		505	CFM	13621	13125	12602	12022	11359	9878				
			BHP	1.74	1.83	1.92	1.99	2.04	2.06				
			Sones	20	20	19.8	19.0	18.6	17.9				
3	VG-3	543	CFM	14646	14184	13705	13209	12606	11302	9606			
			BHP	2.17	2.26	2.36	2.45	2.50	2.56	2.52			
			Sones	22	22	21	21	20	19.3	18.2			
		580	CFM	15644	15212	14769	14306	13783	12597	11287	9381		
			BHP	2.64	2.74	2.84	2.94	3.02	3.10	3.13	3.02		
			Sones	23	23	23	22	22	21	20	18.4		
5	X	617	CFM	16642	16236	15826	15391	14942	13862	12684	11227		
			BHP	3.18	3.29	3.40	3.50	3.60	3.71	3.76	3.73		
			Sones	25	25	25	24	24	23	22	21		
		654	CFM	17640	17257	16873	16466	16056	15084	14000	12831	11217	
			BHP	3.78	3.90	4.02	4.13	4.24	4.39	4.46	4.48	4.38	
			Sones	27	27	27	26	26	25	23	22	21	
690	CFM	18611	18248	17884	17504	17115	16236	15243	14187	12985	11290		
	BHP	4.44	4.57	4.69	4.81	4.93	5.11	5.21	5.26	5.25	5.09		
	Sones	30	29	28	28	28	27	25	24	23	22		

MAXIMUM BHP AT A GIVEN RPM = (RPM/396)³
 MAXIMUM RPM = 690
 TIP SPEED (ft/min) = RPM x 9.425
 MAXIMUM MOTOR FRAME SIZE = 213T
 AVERAGE DISCHARGE VELOCITY (FPM) = CFM/7.25

Performance certified is for installation type A: Free inlet, Free outlet. Power rating (BHP) does not include transmission losses. Performance ratings do not include the effects of appurtenances (accessories). The sound ratings shown are loudness values in fan sones at 5 ft. (1.5 m) in a hemispherical free field calculated per AMCA Standard 301. Values shown are for installation type A: Free inlet hemispherical sone levels.

Roof Upblast Exhaust Size-360HP: CUBE

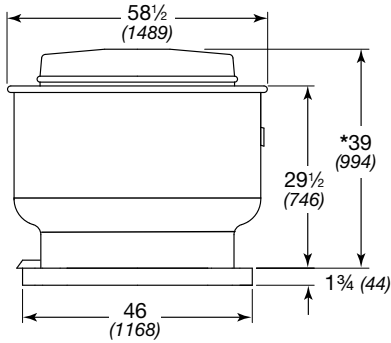

All dimensions in inches (millimeters), weight in pounds (kilograms).
 * May be greater depending on motor.
 ^ Weight shown is largest cataloged open drip-proof motor.

CUBE	
^Approximate Weight	440 (200)
Damper Size	40 x 40 (1016 x 1016)
Roof Opening	42 1/2 x 42 1/2 (1080 x 1080)

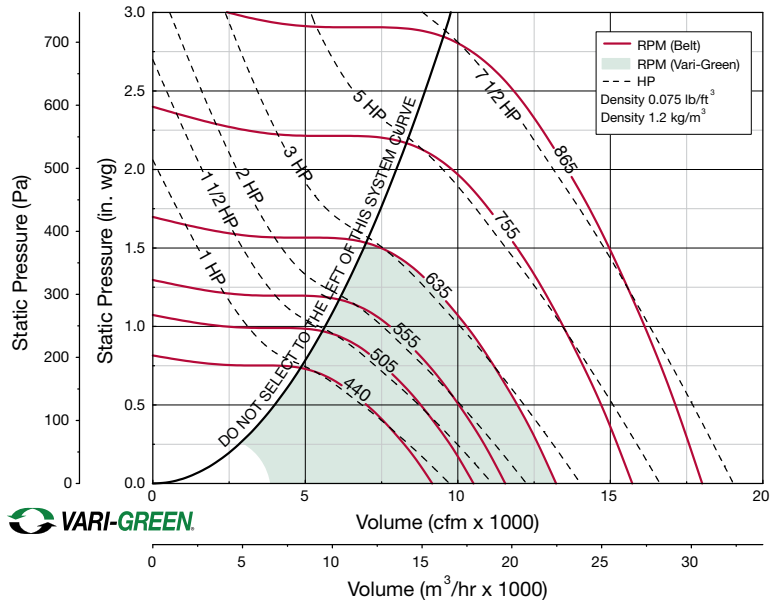

Motor HP	Fan RPM	Static Pressure in Inches wg											
		0.5	0.75	1	1.25	1.5	1.75	2	2.25	2.5	2.75		
360HP													
1	VG-1	CFM	6407										
		BHP	0.90										
		Sones	9.6										
1 1/2		VG-2	CFM	7003									
			BHP	1.03									
			Sones	10.8									
2	VG-3		CFM	8765	7539								
			BHP	1.52	1.57								
			Sones	15.3	14.3								
3		VG-3	CFM	10029	9046	7766							
			BHP	1.97	2.06	2.08							
			Sones	17.2	16.2	15.4							
5	VG-3		CFM	10996	10129	9094	7488						
			BHP	2.40	2.50	2.57	2.49						
			Sones	18.9	17.7	16.8	16.1						
7 1/2		VG-3	CFM	11934	11157	10276	9171	7329					
			BHP	2.87	3.00	3.09	3.12	2.95					
			Sones	21	19.5	18.2	17.8	17.3					
5	VG-3		CFM	13321	12662	11902	11053	10026	8393				
			BHP	3.70	3.86	3.98	4.07	4.09	3.92				
			Sones	24	23	22	20	20	19.6				
7 1/2		VG-3	CFM	14688	14086	13434	12734	11922	10973	9593			
			BHP	4.68	4.86	5.01	5.14	5.23	5.24	5.10			
			Sones	28	27	26	25	24	23	22			
7 1/2	VG-3		CFM	15275	14693	14086	13410	12681	11831	10852	9149		
			BHP	5.15	5.34	5.51	5.64	5.75	5.81	5.79	5.51		
			Sones	30	29	28	27	27	26	24	23		
7 1/2		VG-3	CFM	16232	15689	15137	14511	13869	13127	12290	11354	9683	
			BHP	6.00	6.20	6.40	6.54	6.69	6.78	6.82	6.79	6.48	
			Sones	31	29	27	28	29	28	26	25	24	
7 1/2	VG-3		CFM	17129	16631	16105	15544	14933	14315	13565	12738	11789	10197
			BHP	6.89	7.11	7.32	7.50	7.64	7.79	7.87	7.89	7.83	7.50
			Sones	33	32	30	29	29	29	28	27	25	23

MAXIMUM BHP AT A GIVEN RPM = (RPM/434)³
 MAXIMUM RPM = 865
 TIP SPEED (ft/min) = RPM x 9.425
 MAXIMUM MOTOR FRAME SIZE = 213T
 AVERAGE DISCHARGE VELOCITY (FPM) = CFM/7.25

Performance certified is for installation type A: Free inlet, Free outlet. Power rating (BHP) does not include transmission losses. Performance ratings do not include the effects of appurtenances (accessories). The sound ratings shown are loudness values in fan sones at 5 ft. (1.5 m) in a hemispherical free field calculated per AMCA Standard 301. Values shown are for installation type A: Free inlet hemispherical sone levels.

Roof Upblast Exhaust Size-360XP: CUBE

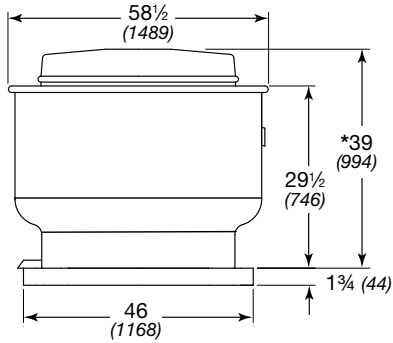

All dimensions in inches (millimeters), weight in pounds (kilograms).
 * May be greater depending on motor.
 ^Weight shown is largest cataloged open drip-proof motor.

CUBE	
^Approximate Weight	440 (200)
Damper Size	40 x 40 (1016 x 1016)
Roof Opening	42 1/2 x 42 1/2 (1080 x 1080)

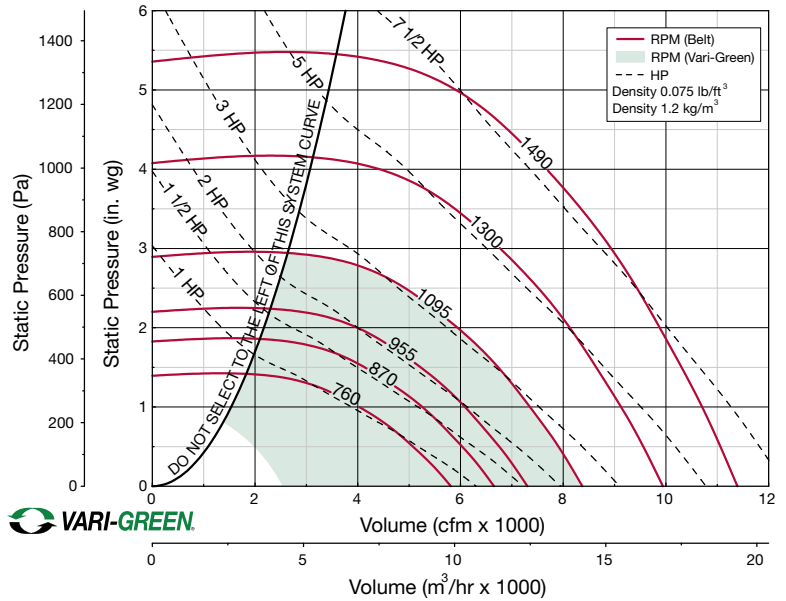

Motor HP	Fan RPM	Static Pressure in Inches wg																					
		1	1.25	1.5	2	2.5	3	3.5	4	4.5	5												
360XP																							
1	VG-1	700	CFM 3210	BHP 0.81																			
		760	CFM 4020	BHP 1.05	3225																		
1 1/2	VG-2	870	CFM 5243	BHP 1.53	4740	4112																	
		955	CFM 6081	BHP 1.97	5679	5216	3949																
3	VG-3	1025	CFM 6722	BHP 2.38	6396	6001	5035	3264															
		1095	CFM 7351	BHP 2.85	7050	6724	5930	4905															
5	X	1163	CFM 7945	BHP 3.36	7669	7386	6712	5867	4700														
		1231	CFM 8528	BHP 3.91	8278	8011	7422	6711	5824	4551													
		1300	CFM 9113	BHP 4.54	8881	8635	8125	7502	6764	5867	4286												
7 1/2	X	1395	CFM 9910	BHP 5.50	9693	9477	9009	8490	7905	7193	6348	5143											
		1490	CFM 10699	BHP 6.61	10496	10294	9871	9429	8907	8340	7673	6881	5830										

MAXIMUM BHP AT A GIVEN RPM = (RPM/748)³
 MAXIMUM RPM = 1490
 TIP SPEED (ft/min) = RPM x 7.069
 MAXIMUM MOTOR FRAME SIZE = 213T
 AVERAGE DISCHARGE VELOCITY (FPM) = CFM/7.25

Performance certified is for installation type A: Free inlet, Free outlet. Power rating (BHP) does not include transmission losses. Performance ratings do not include the effects of appurtenances (accessories). The sound ratings shown are loudness values in fan sones at 5 ft. (1.5 m) in a hemispherical free field calculated per AMCA Standard 301. Values shown are for installation type A: Free inlet hemispherical sone levels.

Roof Upblast Exhaust Size-420: CUBE

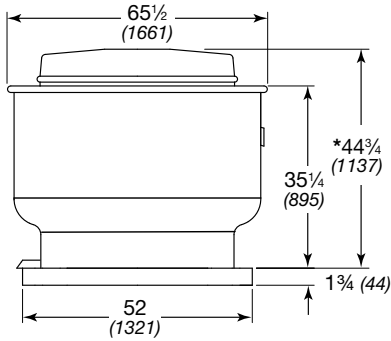

All dimensions in inches (millimeters), weight in pounds (kilograms).
 * May be greater depending on motor.
 ^ Weight shown is largest cataloged open drip-proof motor.

CUBE	
^Approximate Weight	578 (262)
Damper Size	46 x 46 (1168 x 1168)
Roof Opening	48 1/2 x 48 1/2 (1232 x 1232)

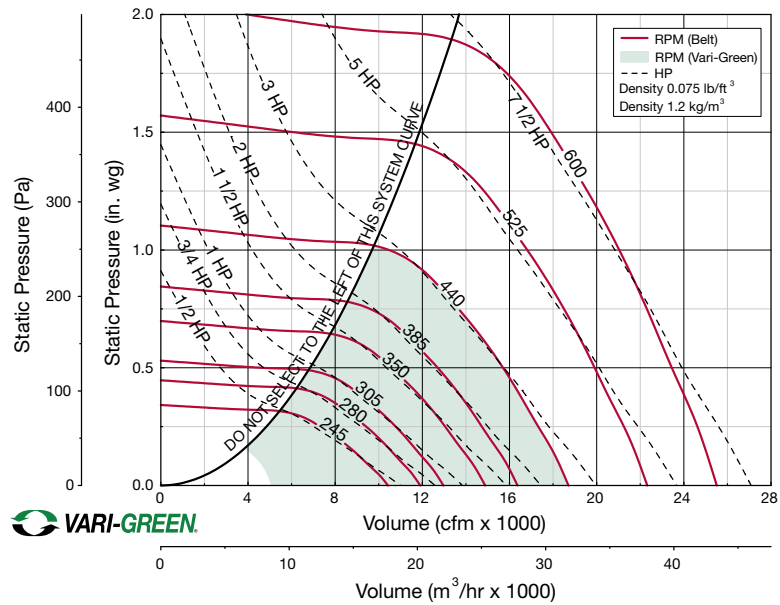

Motor HP	Fan RPM	Static Pressure in Inches wg											
		0	0.125	0.25	0.375	0.5	0.75	1	1.25	1.5	1.75		
420													
1/2	VG-1	220	CFM	9353	7846	5075							
			BHP	0.31	0.37	0.35							
			Sones	6.5	6.0	5.5							
		245	CFM	10416	9104	7304							
			BHP	0.43	0.50	0.53							
			Sones	7.2	6.7	6.1							
3/4	280	CFM	11904	10785	9418	7419							
		BHP	0.64	0.73	0.78	0.77							
1	305	CFM	12966	11959	10781	9272							
		BHP	0.82	0.94	1.00	1.02							
1 1/2	VG-2	350	CFM	14879	14037	13050	11925	10562					
			BHP	1.24	1.38	1.46	1.52	1.54					
			Sones	11.9	11.2	10.1	9.4	8.6					
2	385	CFM	16367	15629	14731	13791	12701	9246					
		BHP	1.65	1.81	1.91	1.99	2.05	1.92					
		Sones	14.4	13.5	12.4	11.7	10.7	8.5					
3	VG-3	415	CFM	17643	16982	16148	15303	14363	12028				
			BHP	2.07	2.24	2.37	2.45	2.53	2.56				
			Sones	17.2	16.1	14.9	13.8	13.0	10.9				
		440	CFM	18706	18103	17316	16532	15691	13652	10151			
			BHP	2.47	2.65	2.81	2.89	2.98	3.07	2.82			
			Sones	17.7	17.1	16.0	14.7	14.6	12.8	10.6			
5	525	CFM	22319	21817	21220	20560	19904	18497	16795	14802			
		BHP	4.19	4.41	4.61	4.78	4.88	5.10	5.20	5.16			
		Sones	23	22	22	21	20	19.1	18.1	17.6			
7 1/2	565	565	CFM	24020	23553	23030	22417	21806	20544	19112	17437	15398	
			BHP	5.23	5.46	5.68	5.88	6.02	6.25	6.43	6.50	6.38	
			Sones	26	25	25	25	24	23	21	21	21	
		600	CFM	25508	25069	24604	24027	23451	22295	21023	19561	17884	15479
			BHP	6.26	6.51	6.75	6.96	7.15	7.38	7.63	7.75	7.77	7.47
			Sones	29	29	29	28	28	27	25	24	24	26

MAXIMUM BHP AT A GIVEN RPM = (RPM/303)³
 MAXIMUM RPM = 600
 TIP SPEED (ft/min) = RPM x 11.06
 MAXIMUM MOTOR FRAME SIZE = 213T
 AVERAGE DISCHARGE VELOCITY (FPM) = CFM/8.99

Performance certified is for installation type A: Free inlet, Free outlet. Power rating (BHP) does not include transmission losses. Performance ratings do not include the effects of appurtenances (accessories). The sound ratings shown are loudness values in fan sones at 5 ft. (1.5 m) in a hemispherical free field calculated per AMCA Standard 301. Values shown are for installation type A: Free inlet hemispherical sone levels.

Roof Upblast Exhaust Size-480: CUBE

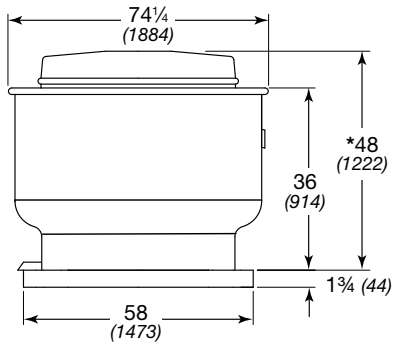

All dimensions in inches (millimeters), weight in pounds (kilograms).
 * May be greater depending on motor.
 ^Weight shown is largest cataloged open drip-proof motor.

CUBE	
^Approximate Weight	675 (306)
Damper Size	52 x 52 (1321 x 1321)
Roof Opening	54 1/2 x 54 1/2 (1385 x 1385)

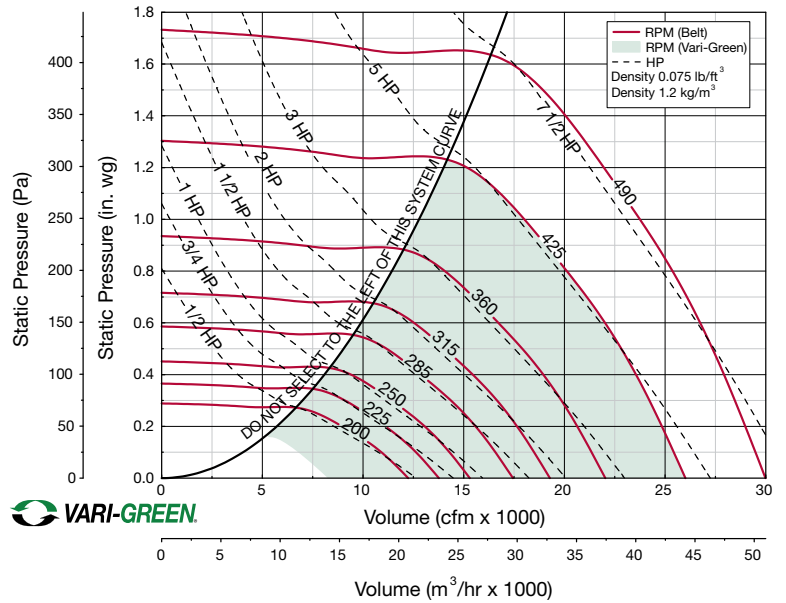

Motor HP	Fan RPM	Static Pressure in Inches wg											
		0	0.125	0.25	0.375	0.5	0.625	0.75	1	1.25	1.5		
480													
1/2	VG-1	180	CFM	11016	8924								
			BHP	0.33	0.39								
	VG-1	200	CFM	12240	10490	7688							
			BHP	0.45	0.53	0.52							
3/4	VG-1	225	CFM	13770	12261	10132							
			BHP	0.65	0.73	0.76							
1	VG-1	250	CFM	15300	13988	12248	9988						
			BHP	0.89	0.98	1.04	1.03						
1 1/2	VG-2	285	CFM	17442	16332	14991	13240	11154					
			BHP	1.31	1.43	1.52	1.55	1.52					
2	VG-2	315	CFM	19278	18274	17116	15719	14033	11996				
			BHP	1.77	1.90	2.01	2.08	2.09	2.03				
3	VG-3	360	CFM	22032	21153	20222	19142	17848	16410	14749			
			BHP	2.64	2.79	2.93	3.05	3.10	3.12	3.08			
5	VG-5	395	CFM	24174	23373	22572	21605	20621	19343	18035	14722		
			BHP	3.49	3.65	3.81	3.94	4.07	4.11	4.13	3.97		
	VG-5	425	CFM	26010	25266	24521	23679	22764	21766	20556	17922		
			BHP	4.35	4.52	4.69	4.85	4.98	5.09	5.12	5.09		
7 1/2	X	460	CFM	28152	27464	26776	26064	25219	24373	23399	21163	18582	
			BHP	5.51	5.70	5.89	6.07	6.22	6.37	6.46	6.52	6.42	
	X	490	CFM	29988	29342	28697	28051	27291	26497	25704	23674	21437	18846
			BHP	6.66	6.86	7.06	7.26	7.43	7.59	7.75	7.85	7.84	7.67
			Sones	28	27	27	26	25	25	24	22	20	24

MAXIMUM BHP AT A GIVEN RPM = (RPM/246)³
 MAXIMUM RPM = 490
 TIP SPEED (ft/min) = RPM x 12.63
 MAXIMUM MOTOR FRAME SIZE = 213T
 AVERAGE DISCHARGE VELOCITY (FPM) = CFM/11.72

Performance certified is for installation type A: Free inlet, Free outlet. Power rating (BHP) does not include transmission losses. Performance ratings do not include the effects of appurtenances (accessories). The sound ratings shown are loudness values in fan sones at 5 ft. (1.5 m) in a hemispherical free field calculated per AMCA Standard 301. Values shown are for installation type A: Free inlet hemispherical sone levels.

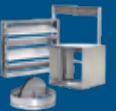

Building Value in Air

Greenheck delivers value to mechanical engineers by helping them solve virtually any air quality challenges their clients face with a comprehensive selection of

top quality, innovative air-related equipment. We offer extra value to contractors by providing easy-to-install, competitively priced, reliable products that arrive on time.

And building owners and occupants value the energy efficiency, low maintenance and quiet dependable operation they experience long after the construction project ends.

Our Commitment

As a result of our commitment to continuous improvement, Greenheck reserves the right to change specifications without notice.

Product warranties can be found online at Greenheck.com, either on the specific product page or in the literature section of the website at Greenheck.com/Resources/Library/Literature.

