



INDUSTRIAL PROCESS AND
COMMERCIAL VENTILATION SYSTEMS

MIXED FLOW INDUCED FLOW EXHAUST FANS

Model QIFE



**AMCA 260
TESTED**



Overview

QIFE



Twin City Fan & Blower offers a specially modified version of the QSL fan designated as "QIFE" for induced flow laboratory fume hood exhaust applications, available in sizes 90 through 542.

The QIFE fan consists of a vertically mounted QSL unit with one of three different nozzles and specially designed windband to maximize dilution ratio (overall outlet volume/lab outlet volume) and plume height.

Mounted on a modular designed mixing plenum box or curb cap, the QIFE is capable of generating an induced flow to meet stringent roof exhaust requirements.

QIFE fans in a standard configuration utilize a heavy-duty curb cap. An optional modular mixing plenum box includes an integrated curb cap.

Benefits of Mixed Flow Fans

Twin City Fan & Blower Model QIFE Mixed Flow Induced Flow Fans combine the benefits of axial flow and centrifugal flow fans with the added benefit of entraining ambient air for a pre-diluted plume. The QIFE has the advantages of an axial fan in its compact design and straight-through airflow combined with a centrifugal fan's preferred acoustical characteristics and high pressure capabilities. QIFE fans offer superior air and sound performance and the AMCA certified rating seal for air and sound.

Sizes

12.25" to 66" impeller diameters

Performance

Airflow to 71,000 CFM
Static pressure to 8" w.g.



Twin City Fan & Blower certifies that the Model QIFE Mixed Flow Induced Flow Exhaust Fans shown herein are licensed to bear the AMCA Seal. Certified performance data may be found in Twin City Fan & Blower's Fan Selector software.



Scan the QR code to search Twin City Fan & Blower's AMCA-certified products.



Model QIFE is available with UL/cUL 705 listing, for electrical, File No. E158680.



For complete product performance, drawings and available accessories, download our Fan Selector software at tcf.com.

Application

QIFE

The QIFE Induced Flow Mixed Flow Exhaust Fan is intended for use in exhausting laboratory fumes and hazardous chemicals in such a manner that diminishes the likelihood of concentrated, contaminant-laden air from being re-entrained into the building's intake or makeup air. This unit is commonly used in exhaust systems for universities, schools, hospitals, research facilities, laboratories and wastewater treatment plants.

Induced flow exhaust fans dilute contaminated air at the outlet as well as increase the outlet volume of the fan. This accelerates the discharge air, increasing plume height without a tall stack.

Energy Recovery Systems

Twin City Fan & Blower's fume exhaust fans are designed to work seamlessly with energy recovery technology, offering efficient ventilation solutions for various applications. The combination of these fans with energy recovery systems ensures optimal air quality and energy efficiency, making them an excellent choice for environmentally conscious projects.

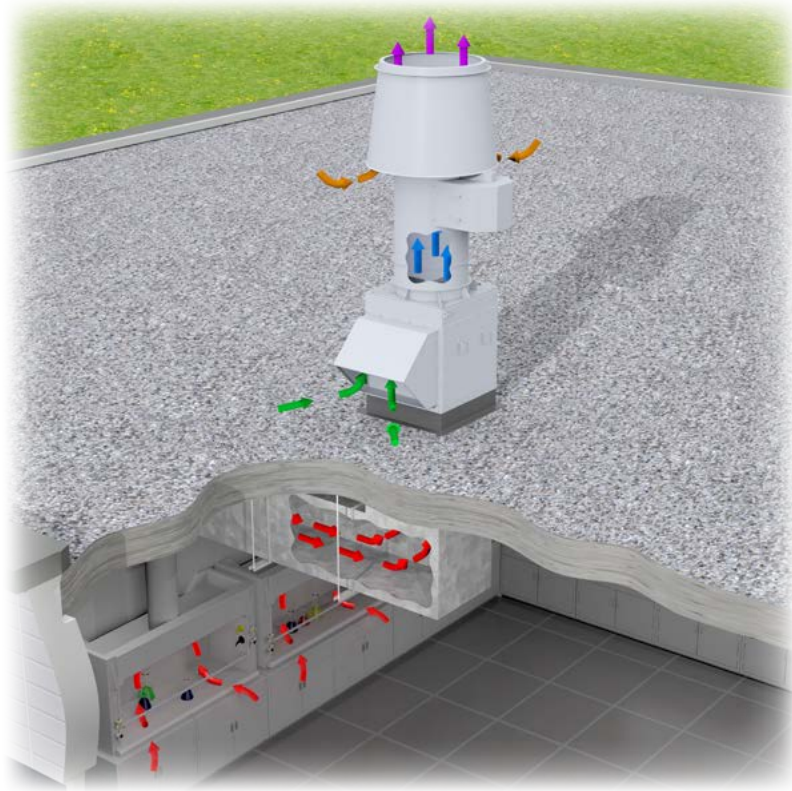

Energy Regulations

Twin City Fan & Blower supports energy efficiency regulations enacted by the U.S. Department of Energy (DOE) and specific states. The selection and application of fan products is a significant part of these regulations. Engineers and specifiers must understand how to apply TCF products to their specific applications to meet applicable DOE and state regulatory requirements. Twin City Fan & Blower has made significant investments in product testing and development to provide efficient products. Developments in Twin City Fan & Blower's Fan Selector software are in place to aid your decision in product selection to assist with meeting the efficiency requirements as stipulated in the applicable regulations.

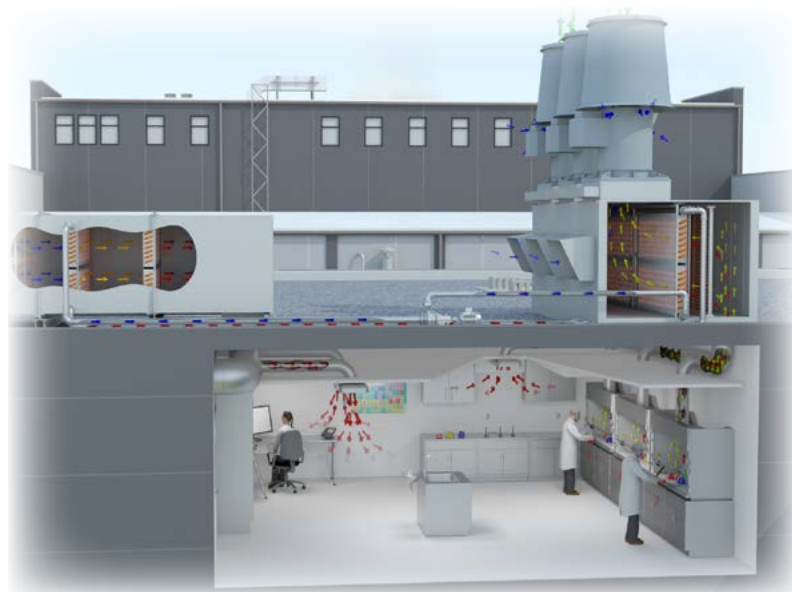



Inner Cylinder tube is rigidly constructed to support the shaft and bearings. The removable discharge cone provides full access to the shaft, bearings and fan sheave.

Drain coupling welded to the lowest point of the housing allows drainage of condensate from fan housing.

Nozzle Drain A drain tube routed to the outside of the housing allows for drainage of the nozzle tray, reducing the amount of precipitation entering the fan housing.

NOTE: While precipitation entry into the fan and duct system is greatly reduced while the fan is in operation, precipitation may enter in while the fan is not operating. Care must be taken by the system designer, building owner and user to consider precipitation mitigation and moisture draining for the fume exhaust system.

Windbands are designed to maximize plume height and entrainment air. Constructed of heavy-gauge steel for strength and rigidity, the windband is mounted directly to the fan housing.

Straightening Vanes convert tangential velocity pressure into useful static pressure, reducing turbulence and increasing efficiency. Extensive testing of various shapes and locations has resulted in the most efficient aerodynamic design of the straightening vanes.

Bolted Access Door for inspection or cleaning of the impeller.

Weather Cover completely encloses the motor and V-belt drive from the elements. Provided with slots for ventilation, covers are easily removable for inspection and maintenance.

Heavy-Duty Motor Mounting Platform pivots to offer easy and positive adjustment of belt tension.

Impeller is designed with die-formed, continuously-welded single-thickness or airfoil blades for a stable air performance throughout the operating range.

Curb Cap attaches to the fan's flange for curb mounting. Standard accessory on QIFE without mixing plenum box.

Extended Lube Lines allow for ease of lubrication on all sizes.

Stainless Steel Hardware is standard for corrosion resistance.

Bearings are selected to exceed the L-10 life of 200,000 hours at the maximum operating speed.

Drives - Cast iron, adjustable or fixed pitch drives are selected for at least 200% of motor horsepower. Adjustable sheaves are provided on motors up to 10 HP, fixed sheaves for 15 HP and above.

V-belt drives with motors and drives mounted by Twin City Fan & Blower are set to the required RPM and test run as a complete assembly and rechecked for balance.

Sealed Belt Tube encloses the belts and drive components, protecting them from the airstream.

Shaft Seal limits the air entering the inner cylinder and avoid contact of airstream contaminants with the bearings and V-belt drive. Consists of a Teflon wear pad/plate and a rubber chekseal at the impeller end of the inner cylinder. Please note that a shaft seal does not make the inner cylinder gas tight.



Unique applications require unique configurations. With the Twin City Fan & Blower Modular Mixing Box, multiple configurations are able to be easily created and retrofitted.



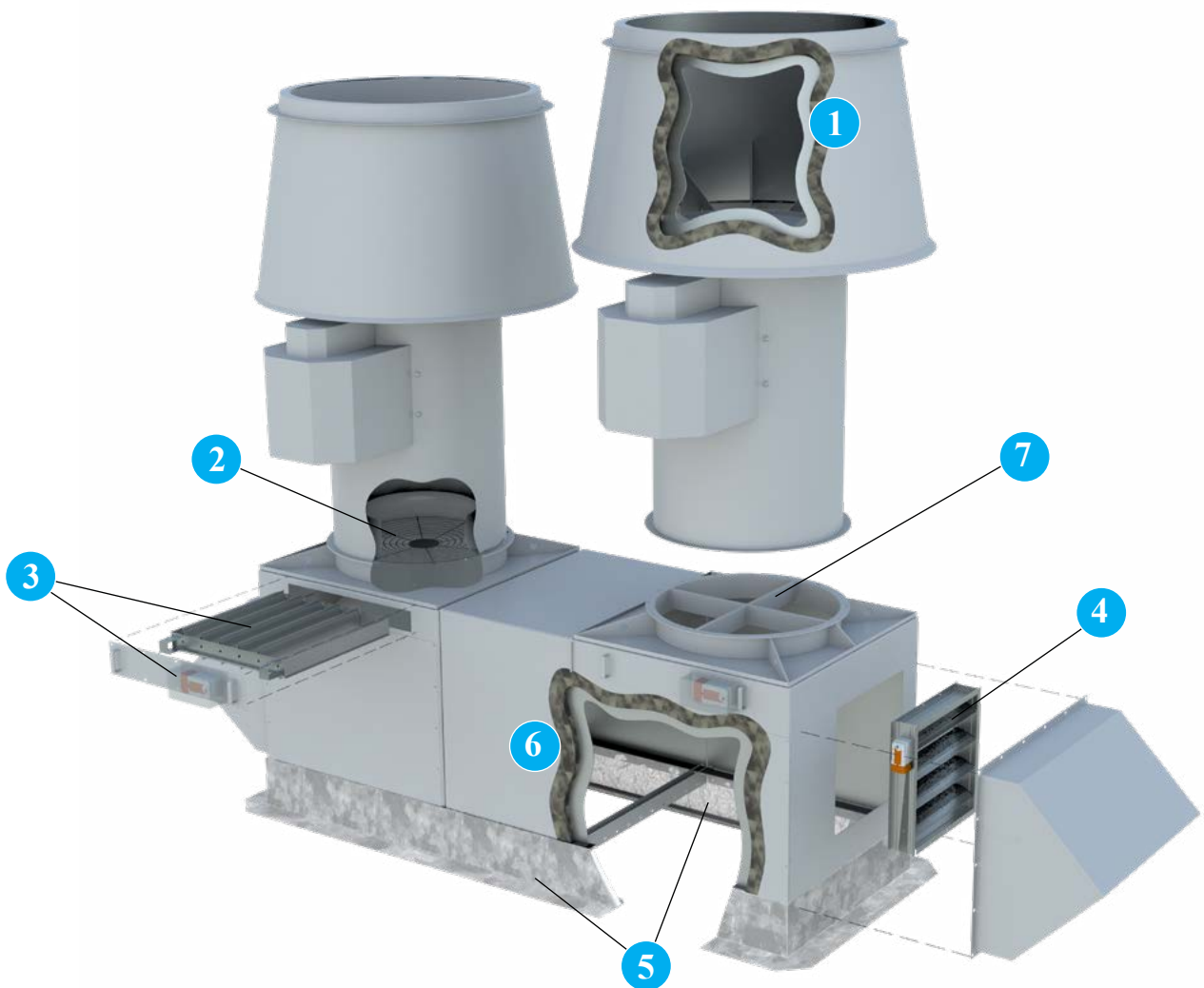

1 Acoustic Windband Designed to reduce noise of the fan system by attenuating sound at the fan outlet.

2 Inlet Safety Screens can be provided for installation in the fan inlet.

3 Isolation Dampers are typically used on multi-fan systems to isolate individual fans. Isolation dampers are available with 2-position, spring-return controls and various materials of construction and coating options.

4 Bypass Damper are used to maintain outlet velocities by allowing a constant volume at the fan when exhaust air is reduced. Bypass dampers are available with either a manual, locking quadrant (handle) or with electrical controls and various materials of construction and coating options.

5 Insulated Roof Curb Standard roof curbs are 12" high and are constructed of heavy-duty galvanized steel and include 1 1/2" thick insulation. Contact factory for other roof curb options. Note: 125 mph windload ratings require a Twin City Fan & Blower supplied roof curb. Parallel backdraft dampers are available for mounting in roof curbs.

6 Mixing Plenum Box w/ Weather Hood; w/ Insulation & Stainless Steel Liner Bottom Intake The mixing plenum box features modular construction allowing for multiple configurations and effortless retrofitting. Bottom intake is standard, side intake option available upon request.

7 Vortex Breaker Installed in the mixing plenum box at the fan inlet, the vortex breaker minimizes air 'swirl'. Recommended for multi-fan configurations and where mixing box intakes are not directly across from the inlet of the fan.

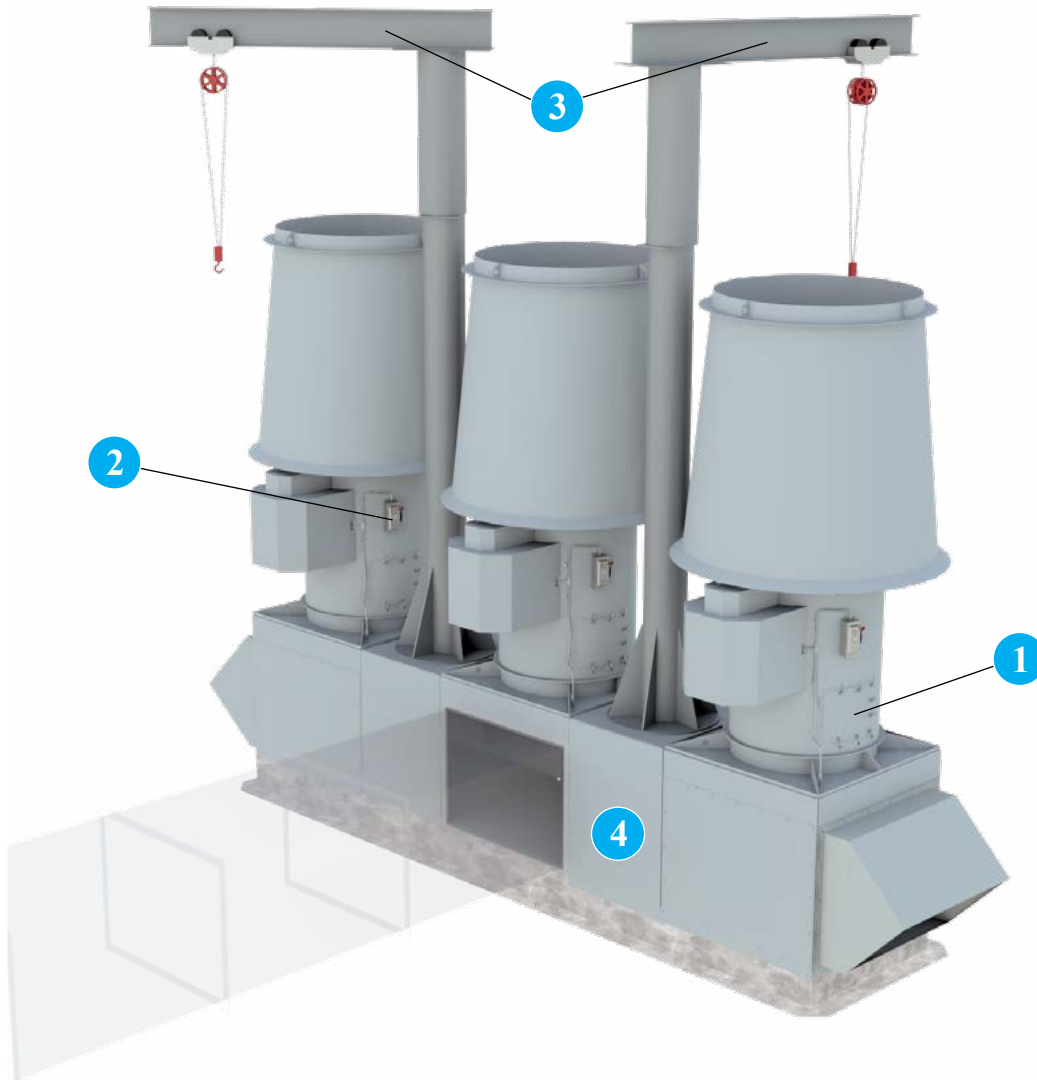

1 Quick Open Access Doors are designed for quick impeller inspection and maintenance. Access doors are specified where examination and cleaning of the fan interior is frequently required.

2 NEMA 3R Disconnect Switch, rain proof, disconnect is available shipped loose for field mounting and wiring or factory mounted and wired. Also available with a NEMA 4 or 7/9 switch.

3 Jib Crane Heavy-duty jib crane is designed to handle the weight of the heaviest individual component. The mount is connected to the specially reinforced mixing box spacer mixing box structure. Single and double mixing boxes receive one (1) jib crane. 3x1 and 4x1 configurations receive two (2) jib cranes.

4 Mixing Plenum Box w/ Weather Hood; Side Intake The mixing plenum box features modular construction allowing for multiple configurations and effortless retrofitting. Bottom intake is standard, side intake option available upon request.

OTHER ACCESSORIES:

- Mixing Box Blank-Off Panel
- Piezometer Ring and Pressure Transducer
- Spark Resistant Construction: Type C
- Stainless Steel Nameplate
- Backdraft damper

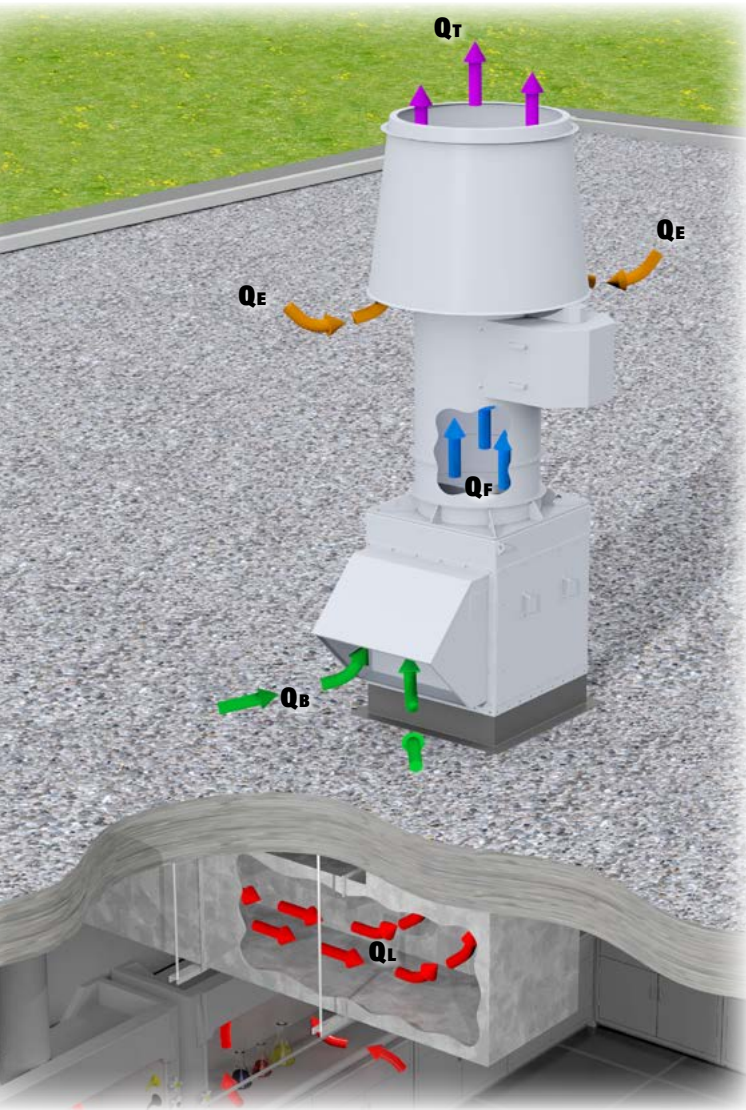

QB = Bypass Flow

QE = Entrained Flow

QF = Fan Flow

QL = Laboratory Flow (Contaminated Air)

QT = Total Flow

$$Q_T = Q_E + Q_F$$

$$Q_F = Q_B + Q_L$$

$$\therefore Q_T = Q_E + Q_B + Q_L$$

$$\text{Dilution Ratio} = \text{D.R.} = \frac{Q_T}{Q_L}$$

$$\text{Entrainment Ratio} = \text{E.R.} = \frac{Q_T}{Q_F}$$

Bypass Air

Ambient air that is drawing through the bypass air plenum and mixed with the lab exhaust to increase dilution and plume rise. Bypass air is primarily used in variable volume applications to maintain a constant discharge volume.

Dilution Ratio

The ratio of the total fan outlet volume to the lab exhaust volume. (Total Volume/Lab Exhaust Volume).

Entrainment Air

Air that is entrained (induced flow) through the windband and mixed with the lab exhaust to increase the dilution ratio and plume rise.

Fume Exhaust

Caustic or noxious air that is being exhausted from laboratory or fume hood.

Nozzle

Device located internal to the fan housing, providing fume exhaust air to accelerate upon entrance to the windband. Three nozzles per fan size are available on the QIFE; low-velocity, medium-velocity and high-velocity. Each nozzle provides different flow characteristics. Nozzle should be selected based on the application requirements.

Plume Rise

The height of the fume exhaust and entrainment air above the discharge of the windband.

Plume Height

Overall height of the discharge plume rise, plus the added height of the exhaust system above the roof-deck level. (See diagram on page 9.)

Total Airflow

The total airflow exiting the windband, including fume exhaust, bypass air and entrainment air.

Windband

Device used to direct the fume exhaust as it leaves the housing of the exhaust fan and entrain dilution air. Also available with an acoustically attenuated option.

The following illustrations describe the procedure for determining the total laboratory exhaust fan discharge flow. The total discharge flow is the sum of inlet airflow and entrained airflow. The key requirement to AMCA 260 is the variable resistance box. This box allows the measurement of total discharge flow ($P_s = 0$ in. w.g. to simulate discharging the fan to atmosphere) at all points along its fan curve.

Without the variable resistance box, the entrained airflow can only be measured at the free air point of its fan curve. The entrained airflow obtained can be used to calculate an effective plume height. Therefore, AMCA 260 certification is necessary to ensure the laboratory exhaust fan specified is providing the plume rise and entrainment submitted.

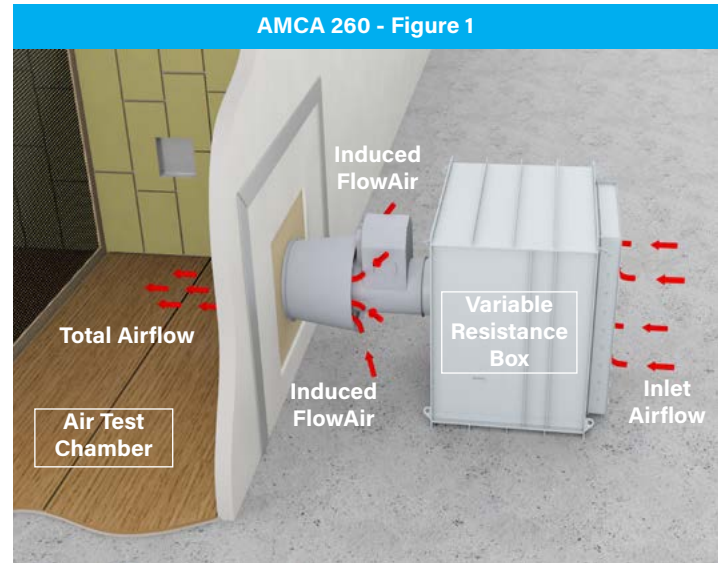
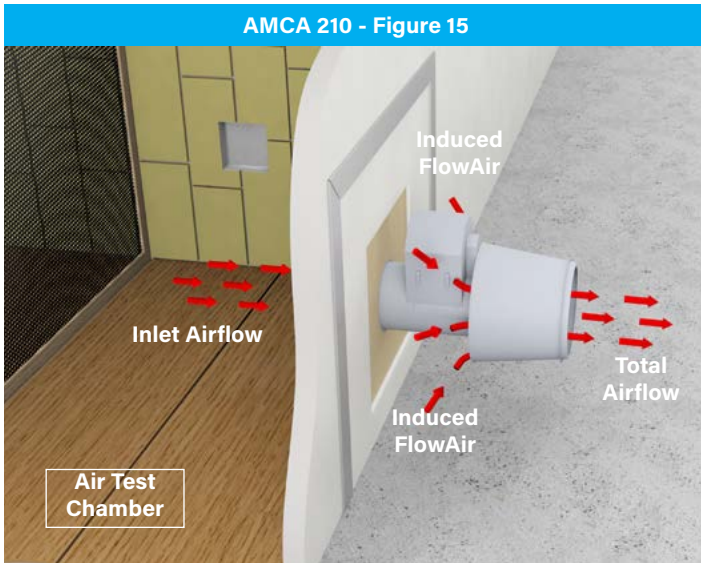

PLUME HEIGHT CALCULATION

$$h_e = h_r + h_s^*$$

$$h_e = [3.0 \times (V \times d / U)] + h_s$$

- h_e = Effective plume height (ft)
- h_r = Plume rise (ft)
- h_s = Stack height (height from roof to outlet of windband) (ft)
- V = Windband exit velocity (ft/min)
- d = Windband outlet diameter (ft)
- U = Crosswind speed (ft/min)

* Equation taken from ASHRAE Laboratory Design Guide, Equation 9-2.
 Note: Plume height calculations are typically calculated with a 10 mph (880 ft/min) crosswind.

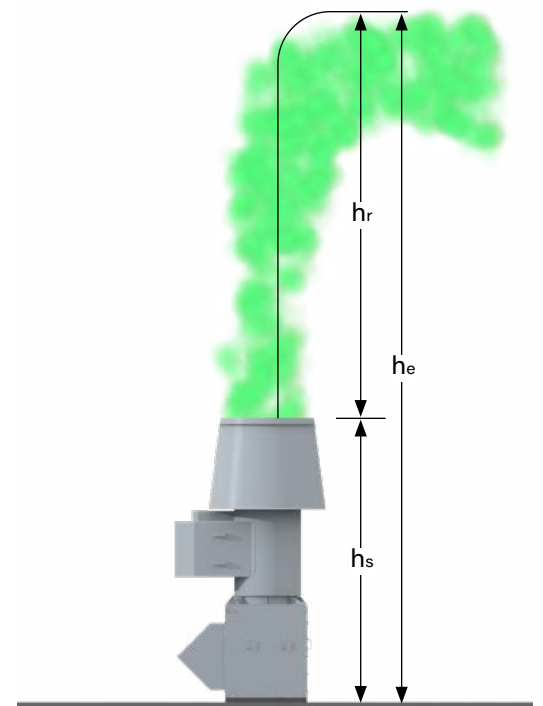

Table 1. Maximum RPM, Impeller Weights and WR^2 (moment of inertia in lb-ft²)

FAN SIZE	CLASS I			CLASS II		
	MAX. RPM	WEIGHT LB.	WR^2 LB-FT ²	MAX. RPM	WEIGHT LB.	WR^2 LB-FT ²
90	4225	9	1.05	-	-	-
122	3450	12	2.15	-	-	-
135	3137	15	3.50	-	-	-
150	2721	24	5.5	3558	28	71
165	2483	32	8.0	3247	36	10.3
182	2232	38	12	2918	44	15
200	2027	48	20	2650	52	23
222	1839	57	29	2405	62	34
245	1655	69	45	2165	75	52
270	1505	82	66	1968	90	76
300	1360	140	133	1779	150	145
330	1234	167	197	1613	179	215
365	1116	233	320	1459	247	347
402	1013	324	588	1325	324	588
445	915	393	883	1197	393	883
490	828	478	1321	1082	478	1321
542	752	591	1934	984	591	1934

Table 2. Bare Fan and Windband Weights (lb)

FAN SIZE	COMPLETE FAN WITH WINDBAND		WINDBAND ONLY
	CLASS I	CLASS II	
90	327	-	146
122	445	-	214
135	523	-	257
150	553	560	220
165	657	665	262
182	757	769	321
200	921	931	386
222	972	984	355
245	1134	1144	434
270	1313	1329	521
300	1703	1733	633
330	2075	2094	765
365	2208	2237	634
402	2721	2746	763
445	3208	3240	929
490	3926	3942	1128
542	4866	4899	1358

NOTE:
Weights do not include motor, mixing plenum box or roof curb. See Table 5 for mixing plenum box weights. Includes bare fan and windband.

Table 3. Temperature and Altitude Density Ratios

AIR TEMP °F	ALTITUDE IN FEET ABOVE SEA LEVEL											
	0	1000	2000	3000	4000	5000	6000	7000	8000	9000	10000	15000
	BAROMETRIC PRESSURE IN INCHES OF MERCURY											
	29.92	28.86	27.82	26.82	25.84	24.90	23.98	23.09	22.22	21.39	20.58	16.89
-50	1.293	1.247	1.201	1.159	1.116	1.076	1.036	0.997	0.960	0.924	0.889	0.729
0	1.152	1.111	1.071	1.032	0.995	0.959	0.923	0.889	0.856	0.824	0.792	0.650
70	1.000	0.964	0.930	0.896	0.864	0.832	0.801	0.772	0.743	0.714	0.688	0.564
100	0.946	0.912	0.880	0.848	0.818	0.787	0.758	0.730	0.703	0.676	0.651	0.534
150	0.869	0.838	0.808	0.770	0.751	0.723	0.696	0.671	0.646	0.620	0.598	0.490
200	0.803	0.774	0.747	0.720	0.694	0.668	0.643	0.620	0.596	0.573	0.552	0.453

Table 4. Bearing Specifications

FAN SIZE	CLASS I		CLASS II	
	SHAFT DIA. (IN.)	BEARING	SHAFT DIA. (IN.)	BEARING
90	0.750	SDB	-	-
122	0.750	SDB	-	-
135	0.750	SDB	-	-
150	1.000	SDB	1.187	SDB
165	1.000	SDB	1.437	SDB
182	1.000	SDB	1.437	HDB
200	1.187	SDB	1.437	HDB
222	1.187	SDB	1.437	HDB
245	1.437	SDB	1.687	HDB
270	1.437	SDB	1.687	RB
300	1.437	HDB	1.937	RB
330	1.687	HDB	2.187	RB
365	1.937	HDB	2.187	RB
402	1.937	RB	2.187	RB
445	1.937	RB	2.437	RB
490	2.187	RB	2.437	RB
542	2.437	RB	2.687	RB

NOTES:
1. BEARINGS CODES:
SDB — Standard-Duty Ball such as Dodge SCAH or SKF SY Series
HDB — Heavy-Duty Ball such as Dodge SCMAH or SKF SYM Series
RB — Roller Bearing such as Dodge S2000 or SKF SYR Series
2. Standard bearings are selected to exceed L-10 life of 200,000 hours at the maximum operating speed.

Table 5. Mixing Plenum Box Weights (lb)

FAN SIZE	SINGLE	DOUBLE	TRIPLE	QUAD
90	269	554	852	1148
122	342	706	1086	1464
135	337	708	1095	1484
150	439	906	1392	1880
165	462	964	1488	2012
182	506	1062	1644	2228
200	519	1110	1725	2340
222	738	1590	2478	3368
245	926	1974	3066	4160
270	952	2070	3234	4400
300	1135	2450	3822	5192
330	1320	2824	4392	5960
365	1449	3114	4851	6588
402	1588	3422	5337	7248
445	1814	3892	6057	8224
490	1999	4310	6720	9128
542	2208	4776	7452	10132

NOTES:
1. Weights do not include roof curb or dampers.
2. Weights are for non-insulated, bottom-intake mixing boxes without jib crane mounting.

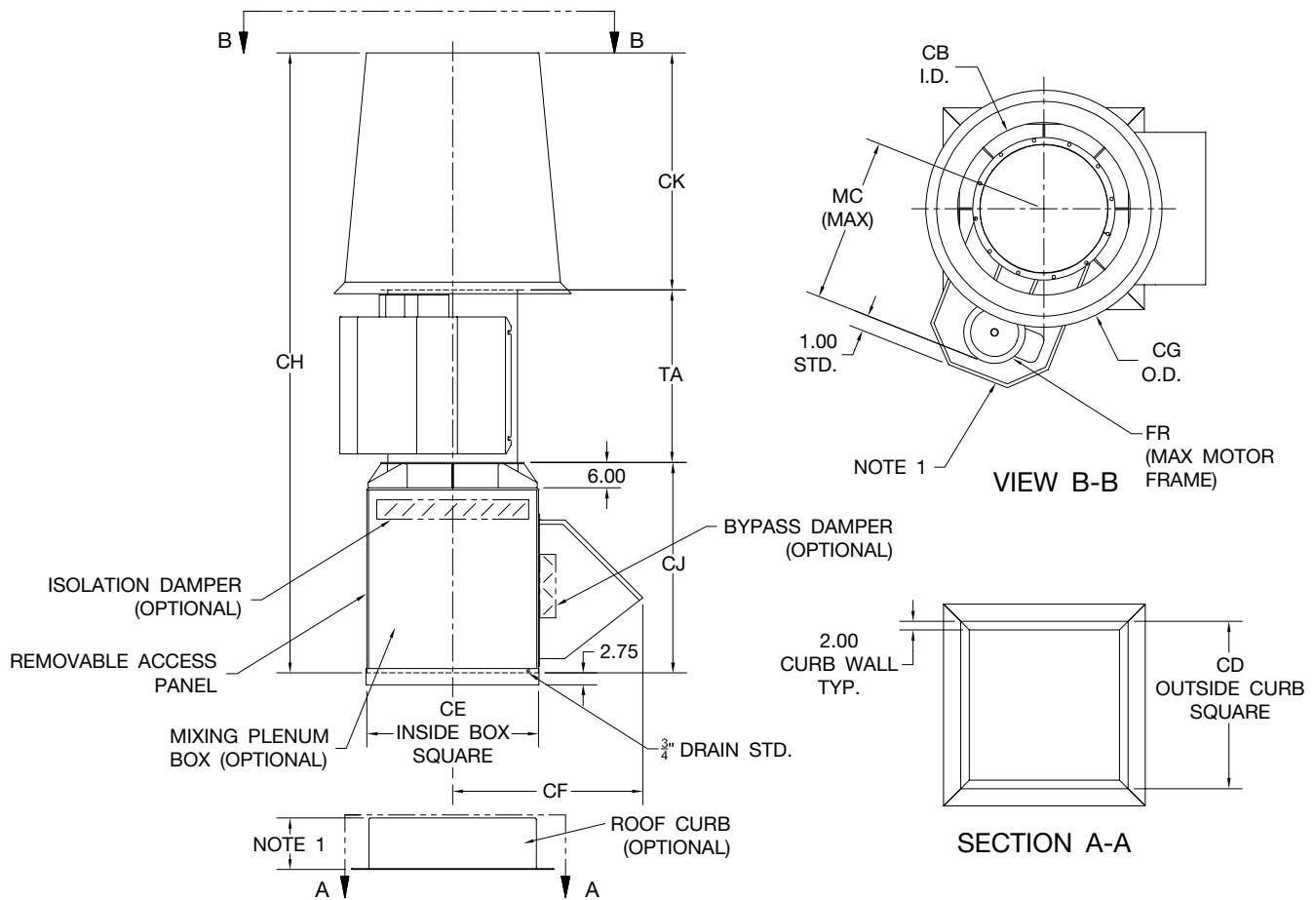

NOTES:

1. Motor position may vary with size.
2. Bottom intake standard; side intake, closed bottom optional.
3. Standard roof curb height is 12". Other heights available upon request.
4. 125 mph windload ratings require a Twin City Fan & Blower supplied roof curb.

SIZE	CB	CD	CE	CF	CG	CH	CJ	CK	FR	MC	SHAFT DIAMETER		TA
											CL I	CL II	
90	18.13	23.00	24.00	28.13	25.00	102.00	33.09	49.44	184T	22.88	0.75	-	19.44
122	22.25	27.00	28.00	32.13	30.63	120.03	37.09	60.69	184T	24.25	0.75	-	22.25
135	24.44	27.00	28.00	32.13	33.69	128.09	37.09	66.87	184T	26.88	0.75	-	24.13
150	27.06	32.00	33.00	37.13	37.25	120.41	42.09	50.44	215T	25.75	1.00	1.19	27.88
165	29.63	33.00	34.00	38.13	40.50	129.04	43.09	55.39	256T	27.75	1.00	1.44	30.76
182	32.69	35.00	36.00	40.13	45.38	140.54	45.09	61.44	256T	34.44	1.00	1.44	34.01
200	36.31	36.00	37.00	41.13	50.00	151.30	46.09	67.69	256T	36.19	1.19	1.44	37.32
222	40.00	39.00	40.00	44.13	55.06	142.10	49.09	52.25	256T	37.63	1.19	1.44	40.32
245	44.44	45.00	46.00	50.13	67.19	157.85	55.09	58.31	286T	37.88	1.44	1.69	44.45
270	48.88	46.00	47.00	51.13	67.31	168.98	56.09	63.94	286T	42.13	1.44	1.69	48.95
300	54.06	52.00	53.00	56.13	74.44	185.60	60.09	70.81	326T	45.13	1.44	1.94	54.70
330	59.63	59.00	60.00	59.63	82.13	197.91	60.09	77.81	326T	46.56	1.69	2.19	60.01
365	65.94	64.00	65.00	62.13	90.75	184.41	60.09	57.81	365T	51.50	1.94	2.19	66.51
402	72.56	70.00	71.00	65.13	99.94	196.97	60.09	63.75	365T	59.75	1.94	2.19	73.13
445	80.38	79.00	80.00	69.63	110.69	211.85	60.09	70.69	405T	62.25	1.94	2.44	81.07
490	88.88	86.00	87.00	73.13	122.38	227.59	60.09	78.31	405T	67.69	2.19	2.44	89.19
542	97.75	94.00	95.00	77.13	134.63	245.15	60.09	86.19	445T	71.50	2.44	2.69	98.87

BC1003133D

DIMENSIONS ARE SUBJECT TO CHANGE. CERTIFIED DRAWINGS AVAILABLE ON REQUEST.



Model QIFE

Model QIFE Induced Flow Exhaust Fans, where indicated on drawings and schedules, shall be of the non-overloading design, and shall be of the size and capacity as indicated in the fan schedule. Induced flow exhaust fans shall be as manufactured by Twin City Fan and Blower, Minneapolis, Minnesota.

PERFORMANCE — Fans shall be tested in accordance with AMCA test codes for air moving devices and shall be guaranteed by the manufacturer to deliver rated published performance levels. Model QIFE shall be licensed to bear the AMCA certified ratings seal for air, sound and induced flow FEI. Sound certification shall apply to both inlet and outlet sound power levels. Model QIFE shall be UL/cUL 705 listed for electrical.

Fans shall be designed for maximum efficiency. Fans shall have a sharply rising pressure characteristic extending through the operating range and continuing to rise well beyond the efficiency peak to assure quiet and stable operation under all conditions. Horsepower characteristics shall be truly self-limiting and shall reach a peak in the normal selection area.

HOUSING — Housings shall be cylindrical and welded steel throughout. Inlets shall be fully streamlined. Housings shall be suitably braced to prevent vibration or pulsation. Totally enclosed weather cover shall enclose motor and V-belt drives. Punched inlet flange shall be equipped for curb cap or mixing plenum box mounting. Extended lube lines shall be provided for ease of lubrication. Model QIFE shall include outlet nozzle, windband, heavy-duty coated steel curb cap, access door, shaft seal and weather cover, and a sealed belt tube for the protection of belts and drive components from the airstream.

IMPELLER — Fan impellers shall have die-formed blades designed for maximum efficiency, and quiet and stable operation. Blades shall be continuously-welded to the back plate and impeller cone. Impellers shall be statically and dynamically balanced and the complete fan assembly including motor and drive shall be test balanced at or near the operating speed at the factory prior to shipment.

SHAFT — Shafts shall be AISI 1045 hot rolled steel, accurately turned, ground, polished and ring-gauged for accuracy. Shafts shall be sized for the first critical speed of at least 1.43 times the maximum speed.

BEARINGS — Bearings shall be heavy-duty, grease lubricated, anti-friction ball or roller, self-aligning, pillow block type and selected for a minimum L-10 life of 200,000 hours at the maximum fan RPM. Bearings shall be equipped with extended lubrication lines with grease fittings outside of the fan housing.

DRIVE — Motor sheaves shall be cast iron, variable pitch on applications 10 HP and smaller, and fixed pitch on 15 HP and larger. Drives shall be sized for at least 200% of motor horsepower.

CURB CAP — A heavy-duty, coated steel or galvanized curb cap shall be included to provide for a weather-tight transition between the roof curb and the fan. The curb cap shall allow discharge height up to 10 feet from roof without the need for guy wire support.

NOZZLE AND WINDBAND — A nozzle and windband combination shall be provided to efficiently induce ambient airflow from outside the fan housing and increase discharge velocities to be a recommended minimum of 3,000 FPM without significantly affecting BHP requirements. The windband shall provide a minimum discharge height of between 84" and 120" from roof surface.



Model

QIFE (cont'd.)

WEATHER COVER — A raintight, easily removable weather cover shall be provided to completely enclose the motor and exposed parts of the V-belt drive.

OPTIONAL ACCESSORIES — Where required the fans shall be provided with:

- AMCA "B" or "C" spark resistant construction
- Modular mixing plenum box
- Bypass damper with actuator
- Isolation damper with actuator
- Disconnect switches
- Roof curb
- Vortex breaker
- Special coatings on airstream parts or entire unit
- Special materials of construction

SUBMITTALS — Submittals for approval of equipment shall include copies of outline drawings, AMCA Certified Ratings and percentage pressure-volume performance curves showing point of operation.



INDUSTRIAL PROCESS AND COMMERCIAL VENTILATION SYSTEMS

CENTRIFUGAL FANS | UTILITY SETS | PLENUM & PLUG FANS | INLINE CENTRIFUGAL FANS
MIXED FLOW FANS | TUBEAXIAL & VANEAXIAL FANS | WALL MOUNTED FANS | ROOF VENTILATORS
CENTRIFUGAL ROOF & WALL EXHAUSTERS | CEILING VENTILATORS | GRAVITY VENTILATORS | DUCT BLOWERS
RADIAL BLADED FANS | RADIAL TIP FANS | HIGH EFFICIENCY INDUSTRIAL FANS | PRESSURE BLOWERS
LABORATORY EXHAUST FANS | FILTERED SUPPLY FANS | MANCOOLERS | FIBERGLASS FANS | CUSTOM FANS



TWIN CITY FAN & BLOWER
WWW.TCF.COM

5959 TRENTON LANE N. | MINNEAPOLIS, MN 55442 | PHONE: 763-551-7600 | FAX: 763-551-7601

©2011-2024 Twin City Fan Companies, Ltd., Minneapolis, MN. All rights reserved. Catalog illustrations cover the general appearance of Twin City Fan & Blower products at the time of publication and we reserve the right to make changes in design and construction at any time without notice.