

## STANDARD CONSTRUCTION

**FRAME:** .081" thick (nominal) extruded aluminum, 6063-T52/T6 alloy

**BLADE:** .081" thick (nominal) extruded aluminum, 6063-T52/T6 alloy.  
Blades approximately 1.625" on centers.

**LOUVER FACE:** Head and blades are contained within jambs, sill contains jambs.

**EXTENDED SILL:** .060" thick (nominal) formed aluminum.

**SCREEN:** (When indicated, in a removable frame.)

½" flattened aluminum (.051" thick),

-or- ½" sq. mesh, intermediate double-crimped aluminum wire, .063" dia.,

-or- 1<sup>5</sup>/<sub>16</sub>" mesh, .011" dia. aluminum wire, insect screen.

**FINISH:** Mill

## OPTIONS

Finish - Baked Enamel, Kynar, Anodize

## NOTES

1. Nominal deductions will be made to opening sizes given.
2. Louvers larger than the maximum factory assembled size will require field assembly of smaller louver sections.
3. Approximate shipping weight is 7.0 lbs./sq.ft.

## LOUVER SIZES

Min Panel	Max Single Panel
12"W x 12"H	30 sq.ft.

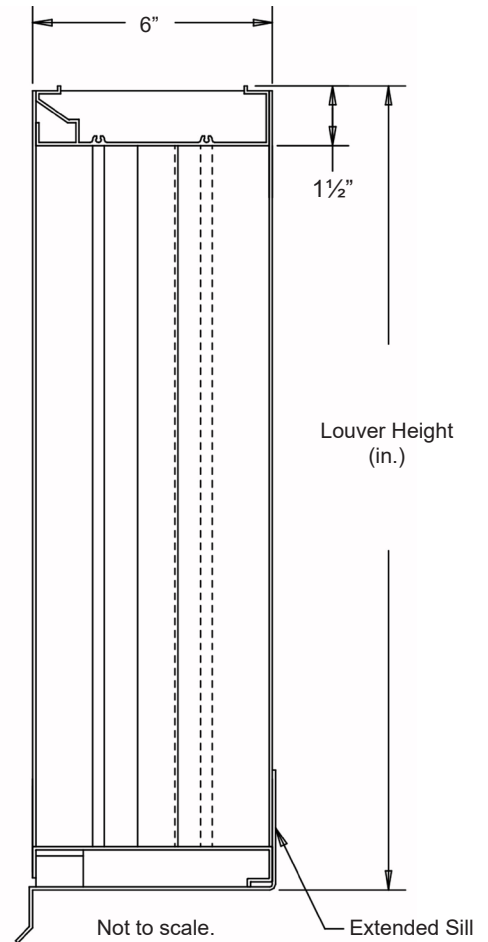
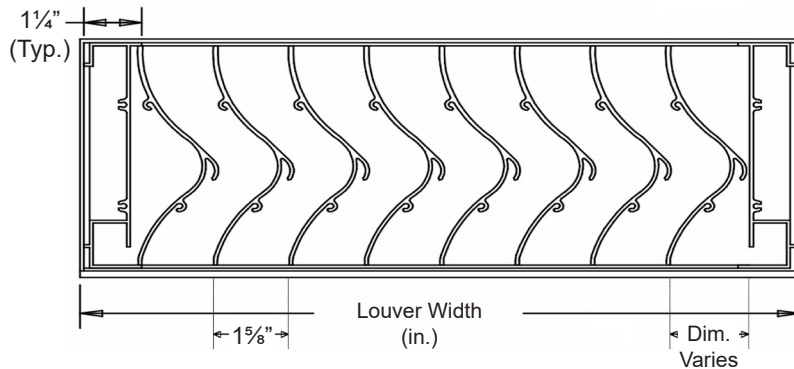

Item #	Qty	Width	Height	Width	Height	Mullion	Type	Location	Union Made
		Opening Size		Louver Size			Screens		
Arch. / Eng. :						EDR:		ECN:	Job:
Contractor:									
Project:						Date:		DWN:	DWG:

In the interest of product development, Louvers & Dampers reserves the right to make changes without notice.

## PERFORMANCE DATA

Pressure Drop: .103 in. w.g. at 1000 fpm (intake)

Free Area: 8.51 sq.ft. = 53% for 48"W x 48"H sample tested in accordance with AMCA Standard 500-L.

Beginning Point of Water Penetration: Over 1250 fpm

Class "A" Rating with 100.0% efficiency at 3 in. rain fall at intake velocity of 1785 fpm (15,190 cfm) at wind speed of 29 mph.

Class "A" Rating with 100.0% efficiency at 8 in. rain fall at intake velocity of 1708 fpm (14,535 cfm) at wind speed of 50 mph.

Testing based on 48" x 48" based on AMCA Standard 500-L.

Ratings do not include effects of a screen.

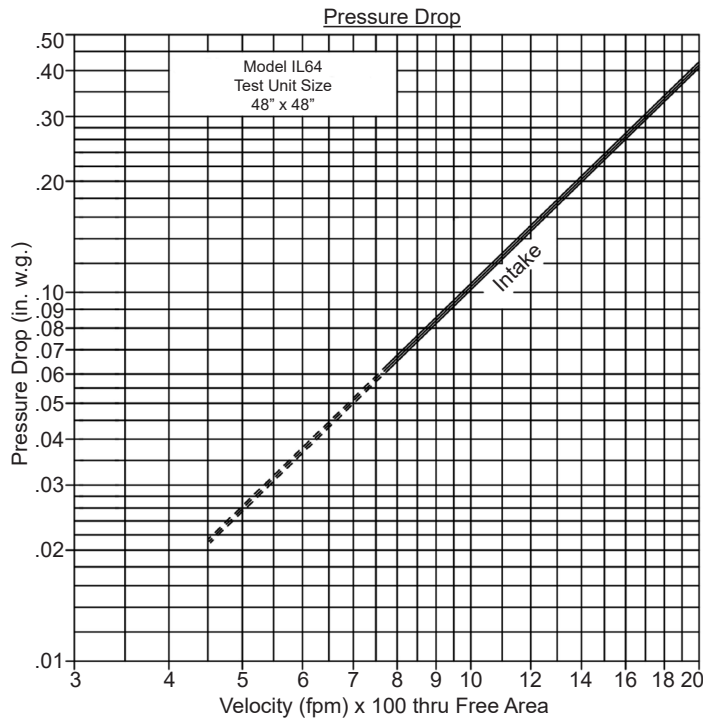

Intake air converted to standard air density.  
Tested to AMCA Standard 500-L, Figure 5.5.

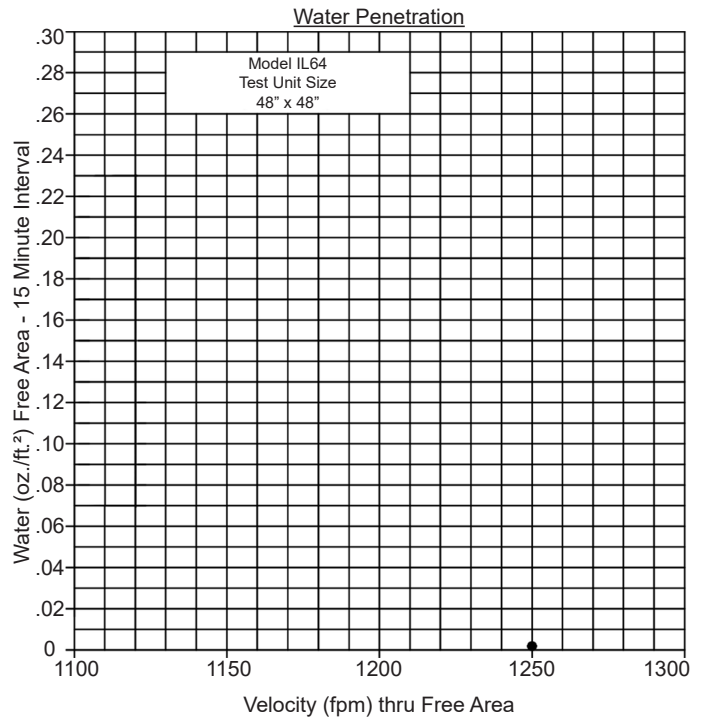

The Beginning Point of Water Penetration is above 1250 fpm through the free area of the louver.

AMCA Standard 500-L limits testing of water penetration to either a maximum velocity of 1250 fpm or 2.5 ounces of water per square foot of louver free area.

Free Area (sq.ft.)

		Width (in.)									
		12"	24"	36"	48"	60"	72"	84"	96"	108"	120"
Height (in.)	12"	.25	.76	1.20	1.71	2.15	2.60	3.10	3.55	3.99	4.50
	24"	.58	1.73	2.73	3.88	4.89	5.90	7.05	8.05	9.06	10.21
	36"	.90	2.69	4.26	6.06	7.63	9.20	10.99	12.56	14.13	15.93
	48"	1.22	3.66	5.79	8.51	10.36	12.50	14.94	17.07	19.20	21.64
	60"	1.54	4.62	7.32	10.40	13.10	15.80	18.88	21.58	24.28	27.36
	72"	1.86	5.59	8.85	12.58	15.84	19.10	22.83	26.09	29.35	33.07
	84"	2.19	6.56	10.38	14.75	18.58	22.40	26.77	30.59	34.42	38.79
	96"	2.51	7.52	11.91	16.92	21.31	25.70	30.71	35.10	39.49	44.50
	108"	2.83	8.49	13.44	19.10	24.05	29.00	34.66	39.61	44.56	50.22
	120"	3.15	9.45	14.97	21.27	26.79	32.30	38.60	44.12	49.63	55.94

Wind Driven Rainwater Penetration Test  
 Conducted to AMCA Standard 500-L.

Test size 1m x 1m (39.7" x 39.7") core area, 41.88" x 41.75" nominal.  
 Louver Free Area 6.0 square feet.

Core Ventilation (m/s)	0.0	0.5	1.0	1.5	2.0	2.5	3.0	3.5	4.0	4.5	5.0	Rain Fall / MPH
FPM	0	98	197	295	394	492	591	689	787	886	985	3 in. / hr. rain fall and 29 mph Velocity
Free Area Ventilation (cfm)	-	-	-	-	-	-	-	-	-	-	10,710	
Free Area Velocity (fpm)	-	-	-	-	-	-	-	-	-	-	1,785	
Effective Rating Class	A	A	A	A	A	A	A	A	A	A	A	
Effective Ratio %	-	-	-	-	-	-	-	-	-	-	100.0	
FPM	-	-	-	-	-	-	-	-	-	-	952	8 in. / hr. rain fall and 50 mph Velocity
Free Area Ventilation (cfm)	-	-	-	-	-	-	-	-	-	-	10,248	
Free Area Velocity (fpm)	-	-	-	-	-	-	-	-	-	-	1,708	
Effective Rating Class	A	A	A	A	A	A	A	A	A	A	A	
Effective Ratio %	-	-	-	-	-	-	-	-	-	-	100.0	

Wind Driven Rain Penetration Classifications

Class	Effectiveness %
A	100 to 99%
B	98.9% to 95%
C	94.9% to 80%
D	Below 80%

Discharge Loss Coefficient Classifications

Class	Discharge Loss Coefficient
1	0.4 and above
2	0.3 to 0.399
3	0.2 to 0.299
4	0.199 and below

Discharge Coefficient  
 Intake Cd= 0.46 (Class 1)

Class 1 Loss Coefficient has the least resistance to airflow.

1. Core area is the front opening of a louver assembly with the blades removed.
2. Core area velocity is the airflow rate through the louver divided by the core area (39.37" x 39.37").
3. Free area is the minimum area through which air can pass. It is determined by multiplying the sum of the minimum distance between intermediate blades, top blade and head, bottom blade and sill, by the minimum distance between jambs.
4. Discharge loss coefficient is calculated by dividing a louver actual airflow rate vs. a theoretical airflow for the opening, providing an indication of the louver air flow characteristics.



Louvers & Dampers certifies that the Model IL64 shown herein is licensed to bear the AMCA seal. The ratings shown are based on tests and procedures performed in accordance with AMCA Publication 511 and comply with the requirements of the AMCA Certified Ratings Program. The AMCA Certified Ratings Seal applies to Water Penetration, Air Performance, and Wind Driven Rain Ratings only.

This is to certify that the "Building Services Research and Information Association" (BSRIA) have type tested the product described below to the requirements contained in the 5th Edition of the HEVAC Technical Specifications "Laboratory Testing and Ratings of Weather Louvers When Subjected to Simulated Wind Driven Rain".

## TEST RESULTS

Based on calibration plated and louver core size of 10.76 sq.ft. (1m<sup>2</sup>)

	CFM (m <sup>3</sup> /s)							
Ventilation Rate Air Flow Rate (CFM)	0	1059 CFM (0.5)	2119 CFM (1.0)	3178 CFM (1.5)	4238 CFM (2.0)	5297 CFM (2.5)	6357 CFM (3.0)	7416 CFM (3.5)
Rating Achieved	A	A	A	A	A	A	A	A

Coefficient of Discharge or Entry: 0.419, Class I

Wind Speed: 30.2 mph (13.5 m/s)

Rainfall: 2.95 in/hr (75 mm/hr)

Example:  $\frac{7416 \text{ CFM (3.5 m}^3\text{/s)}}{10.76 \text{ sq.ft. (1m}^2\text{)}} = 689 \text{ FPM Face Velocity}$  / Sample Louver Free Area 48% = 1435 FPM Free Area Velocity Percentage

## CLASSIFICATIONS OF WEATHER LOUVERS

Extract taken from the HEVAC Technical Specification for reference purposes only.

### Classification for Rain Penetration

Class	Effectiveness (%)	Maximum Allowed Penetration of Simulated Rain oz/ft <sup>2</sup> /hr (l/m <sup>2</sup> /hr)
A	100 to 99%	2.4 (0.75)
B	98.9% to 95%	11.8 (3.75)
C	94.9% to 80%	47.1 (15.0)
D	Below 80%	Greater than 15.0

### Classification for Coefficient of Discharge or Entry

Class	Discharge Loss of Entry Coefficient (%)
1	0.4 and above
2	0.3 to 0.399
3	0.2 to 0.299
4	0.199 and below

This test, (HEVAC), result with the louver obtaining the highest performance classifications for this test method.

### HEVAC Testing at Other Windspeeds and Rainfall Rates

- 30 MPH at 4.72" Rainfall at 1517 FPM (12,910 CFM) ventilation rate through free area is 100% effective.
- 55 MPH at 2.95" Rainfall at 1517 FPM (12,910 CFM) ventilation rate through free area is 100% effective.
- 55 MPH at 4.72" Rainfall at 1600 FPM (13,616 CFM) ventilation rate through free area is 99.99% effective.