

## Culture of Quality

Loren Cook Company is proud to be a leader in the design and manufacturing of fans, blowers, gravity ventilators, lab exhaust systems and energy recovery equipment. Our products ventilate institutional, laboratory, commercial and industrial facilities worldwide. Our culture is to provide superior product quality and excellent customer service. This was true in 1941 when Loren Cook founded the company, and it's still true today. Loren Cook Company is proud to have served our industry so well for three generations.



## Independent Certification

Cook products and procedures are certified and/or tested by many third-party organizations including ISO, AMCA, UL, AHRI, CSA, OSHPD, ISTA, US Green Building Council and Miami-Dade County.

### ISO 9001 Certified

Our globally recognized ISO 9001 quality certification has positioned Loren Cook Company at the very forefront of manufacturing excellence. Cook customers can be assured our products are built to the highest quality standards. We recognize that when you design a system and specify equipment, the consistent quality of the products is critical to your reputation.



### In-House Testing Labs

Our research and development center includes AMCA accredited testing laboratories for both air and sound performance. Additional capabilities include endurance testing, such as over-speed and start-stop, as well as vibration and elevated temperature testing. These critical tests can be performed on-site allowing quick response to new designs and product enhancements.



### Transit Tested Packaging

Our packaging standards are scrutinized as well. All Cook products are shipped in ISTA Certified Transit Test Packaging.

**Ask your Cook rep about a tour of our education center and testing labs.**

## Free design tools

Compute-A-Fan® is a fast, accurate and easy-to-use fan-selection program. This software gives point-and-click access to Cook's products. A comprehensive, cross-reference interface allows the user to select fans based upon the product specifications of any major manufacturer.

### Download

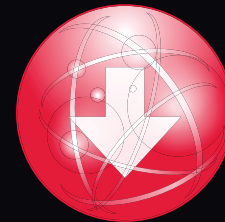

**The single download gives you access to the Compute-A-Fan software, which includes:**

- Fan Law Calculator
- Duct Designer
- Psychrometric Calculator
- English-Metric Converter
- Sound Converter
- Annual Energy Cost Estimator
- FanDrafter® 2D
- FanDrafter® 3D with Revit Models
- Revit® Addin, used with Compute-A-Fan®
- Catalog PDFs
- IOM Manual PDFs
- Engineering Cookbook PDF

The auto update feature will provide you with the latest versions.

The free Digital Media Center also provides a disk version of these information sources.

### DVD-Rom



The DVD-Rom also includes company information, a video about Cook's ISO 9001 certification and a video demonstrating air duct turbulence, known as "system effect."

**Visit [www.lorencook.com](http://www.lorencook.com) for these free tools.**

# CV

## Inline and Roof Mounted Fans

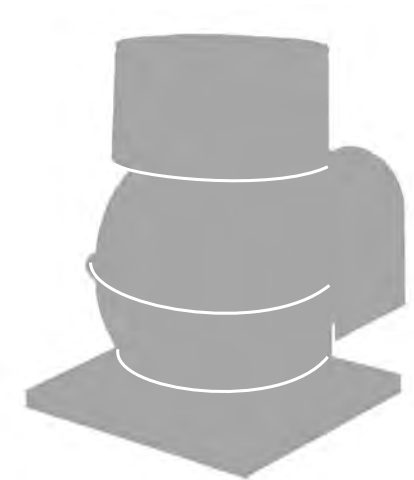
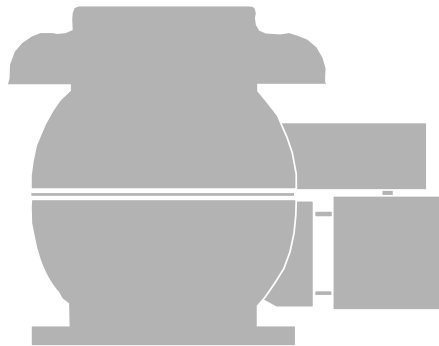
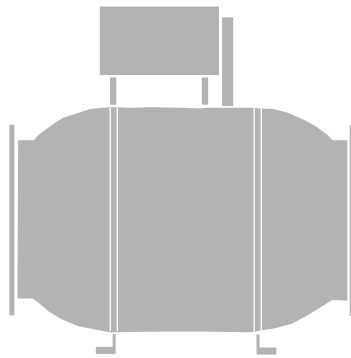
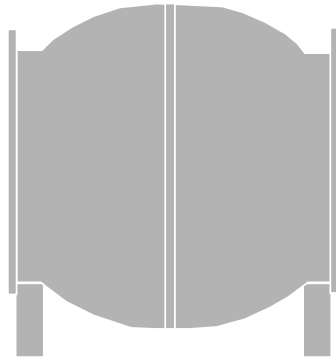

Page

Introduction .....	2
Construction Features .....	3-4
<b>Specifications and Dimension Data</b>	
CVD (Direct Drive Inline) .....	5
CVB (Belt Drive Inline) .....	6
CV-S (Belt Drive High Pressure Inline) .....	7
UCV (Belt Drive Roof Mounted Upblast Exhaust) .....	8
CVR / CVR-S (Belt Drive Roof Mounted Exhaust/Supply) .....	9
Accessories .....	10-12
<b>Performance Data</b>	
CVD .....	13
12-16 CVB .....	14-15
18-24 CVB .....	16-17
28-36 CVB .....	18-19
12-16 CV-S .....	20-21
18-24 CV-S .....	22-23
28-36 CV-S .....	24-25
<b>Sound Data</b>	
CVD .....	26
CVB .....	27-28

# INTRODUCTION

Loren Cook Company's Centri-Vane® and Centri-Vane® Stretch are constructed of aluminum and designed for straight-through air flow. Performance ranges from 50 to 31,200 CFM with static pressures to 6" w.g. The Centri-Vane® belt drive is offered in 9 sizes from 12 to 36 and is available in duct mounted inline and roof mounted supply, exhaust and upblast configurations. The Centri-Vane® direct drive is offered in 7 sizes from 8 to 20 in duct mounted inline configuration.



**CVD**

- Specially designed mixed-flow wheel provides unique performance with stable operation from free air to shutoff.
- True airfoil blades provide non-overloading horsepower characteristics.
- All aluminum construction reduces unit weight and associated installation costs.
- Adjustable mounting brackets permit mounting in any desired position.
- Compact straight-through design saves valuable floor space compared to a conventional centrifugal blower.
- Straightening vanes insure linear movement of air at the fan discharge providing higher efficiency and lower overall noise levels.
- UL / cUL 705 listing is standard on all Centri-Vane® units.
- Models CVB and CVD are licensed to bear the AMCA Certified Ratings Seal for Sound and Air Performance.
- Model CVS is licensed to bear the AMCA Certified Ratings Seal for Air Performance.



**CVB**



**CVS**



**CVR**



**CVR-S**



**UCV**

CVB

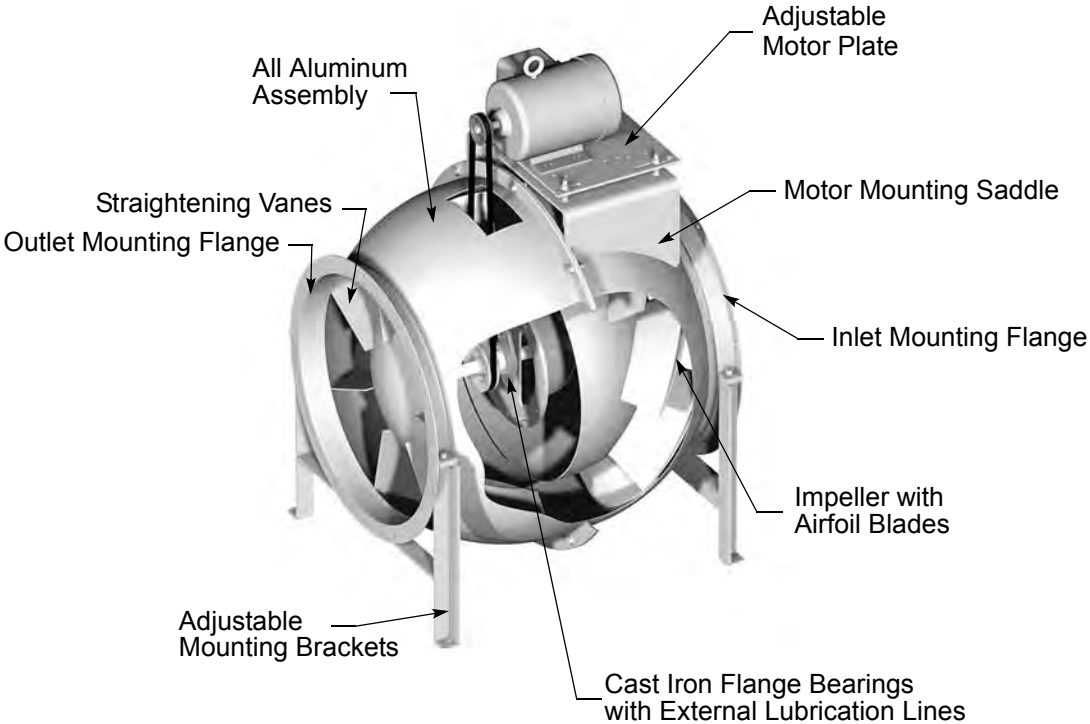

CVS

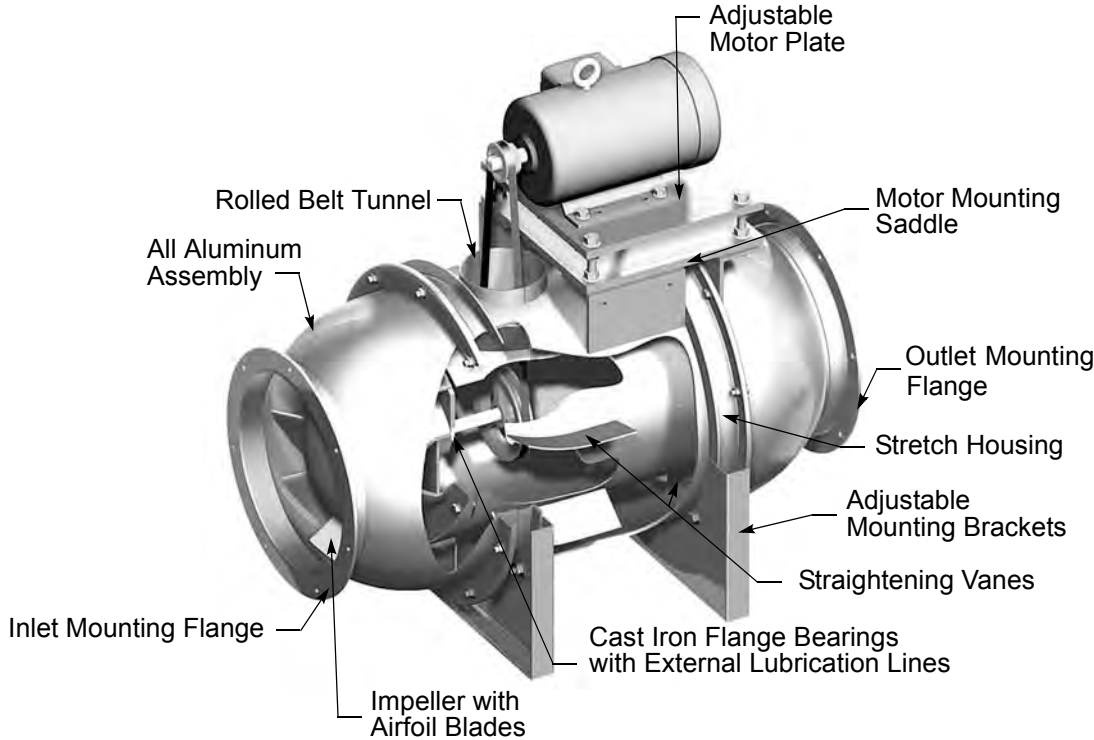



# CONSTRUCTION FEATURES

## CVR

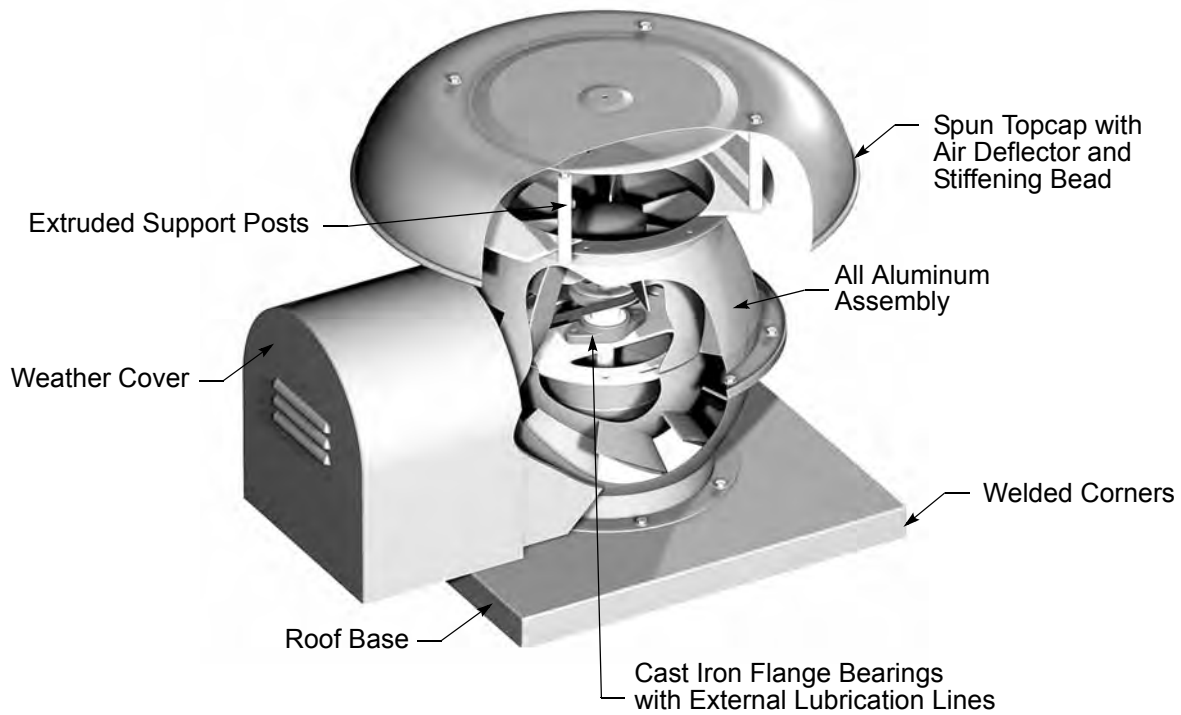

## UCV

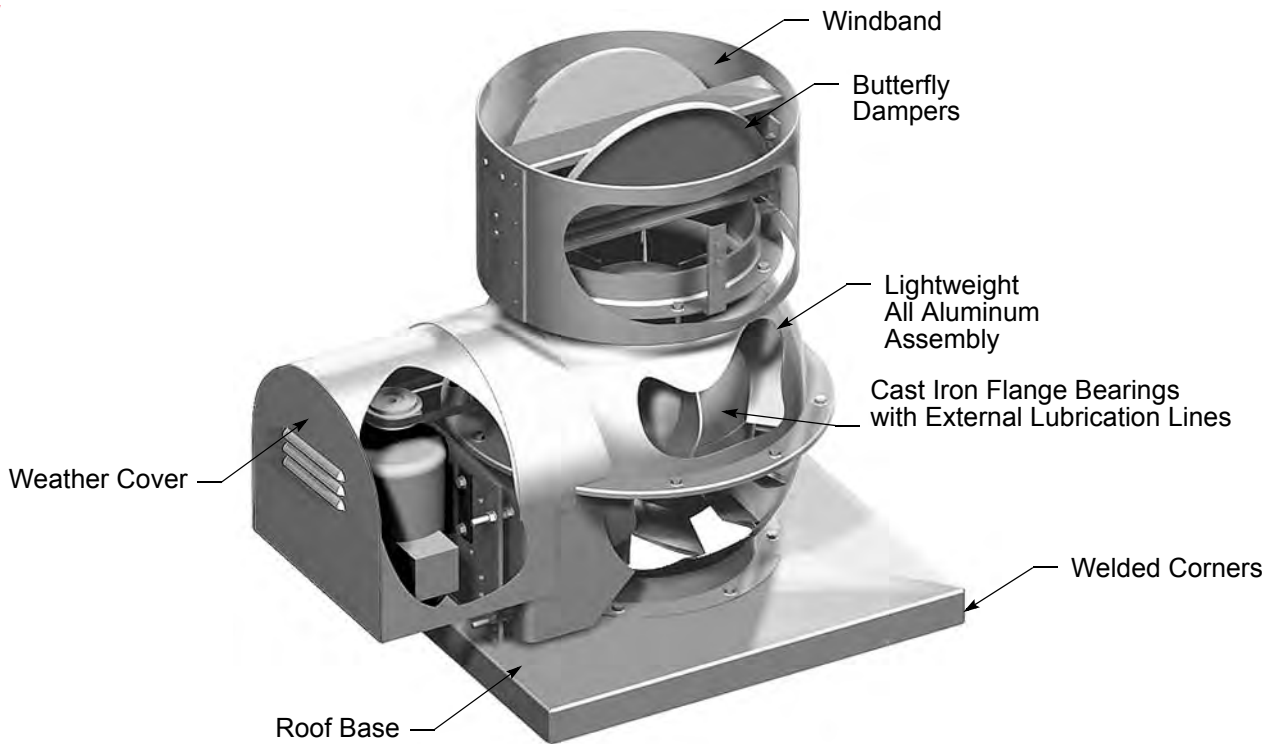

**Description:** Fan shall be a spun aluminum, duct mounted, direct driven, mixed-flow fan.

**Certifications:** Fan shall be listed by Underwriters Laboratories (UL 705) and UL listed for Canada (cUL 705). Fan shall bear the AMCA Certified Ratings Seal for Sound and Air Performance.

**Construction:** The fan shall be bolted and welded construction utilizing corrosion resistant fasteners. The spun aluminum housing shall be constructed of minimum .100 thick marine alloy aluminum with inlet and outlet flanges. Straightening vanes shall be utilized for uniform airflow. The adjustable mounting brackets shall be constructed of minimum .125 thick aluminum with extruded rubber isolation between bracket and fan housing. Unit shall bear an engraved aluminum nameplate and shall be shipped in ISTA Certified Transit Tested Packaging.

**Wheel:** Wheel shall be a non-overloading design utilizing airfoil blades for maximum efficiency. The aluminum airfoil blades shall be welded to a spun aluminum dome. The dome shall be bolted to an aluminum hub assembly. The hub shall be keyed and locked to the fan shaft utilizing two setscrews. Wheel shall be balanced in accordance with AMCA Standard 204-05, Balance Quality and Vibration Levels for Fans.

**Motor:** Motor shall be heavy duty type with permanently lubricated sealed bearings and furnished at the specified voltage, phase and enclosure.

**Product:** Fan shall be model CVD as manufactured by Loren Cook Company of Springfield, Missouri.

## Centri-Vane® All Aluminum Mixed-Flow Fan Direct Drive



### CVD Dimension Data

Size	A	B	C	D	E	F	G	Wheel Diameter	Thickness of Alum.	Approx. Ship. Wt. - lbs.
8	8	13-1/4	13-7/16	7	1-5/16	11-1/4	10-1/4	10-1/4	.100	35
10	10	15	16-3/16	8-11/16		13	12-1/4	12-15/16	.125	65
12	12	17-1/8	19-1/4	9-15/16		15-1/8	14-1/8	15-9/16		82
14	14	19-1/8	22	11-7/16		17-1/8	16-1/4	18-1/4		93
16	16	21-9/16	24-7/8	12-11/16		19-9/16	18-1/4	20-15/16		120
18	18	24-1/2	27-3/4	14		22-1/2	20-3/8	23-9/16		166
20	20	26-3/8	30-1/2	15-3/4	24-3/8	22-1/2	26-1/4	206		

All dimensions in inches. Weights in pounds.



Loren Cook Company certifies that the CVD shown herein is licensed to bear the AMCA Seal. The ratings shown are based on tests and procedures performed in accordance with AMCA Publication 211 and AMCA Publication 311 and comply with the requirements of the AMCA Certified Ratings Program.



Model CVD is furnished standard with UL 705 and cUL 705 listing (Power Ventilator/ZACT) when furnished with factory supplied motor.

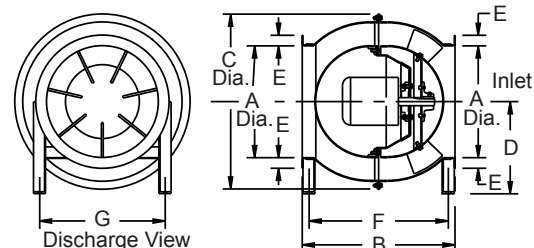

**Centri-Vane®**  
**All Aluminum**  
**Mixed-Flow Fan**  
**Belt Drive**



Loren Cook Company certifies that the CVB shown herein is licensed to bear the AMCA Seal. The ratings shown are based on tests and procedures performed in accordance with AMCA Publication 211 and AMCA Publication 311 and comply with the requirements of the AMCA Certified Ratings Program.



Model CVB is furnished standard with UL 705 and cUL 705 listing (Power Ventilator/ZACT) when furnished with factory supplied motor.

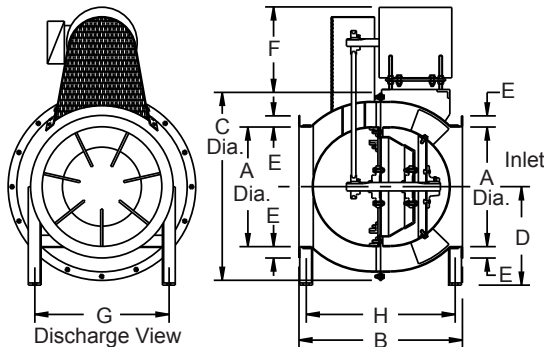

**Description:** Fan shall be a spun aluminum, duct mounted, belt driven, mixed-flow fan.

**Certifications:** Fan shall be listed by Underwriters Laboratories (UL 705) and UL listed for Canada (cUL 705). Fan shall bear the AMCA Certified Ratings Seal for Sound and Air Performance.

**Construction:** The fan shall be bolted and welded construction utilizing corrosion resistant fasteners. The spun aluminum housing shall be constructed of minimum .125 thick marine alloy aluminum with inlet and outlet flanges. Straightening vanes shall be utilized for uniform airflow. Extended lube lines shall be furnished for lubrication of fan bearings. Aluminum adjustable motor mounting plate shall utilize threaded studs for positive belt tensioning. The adjustable mounting brackets shall be constructed of minimum .125 thick aluminum with extruded rubber isolation between bracket and fan housing. Unit shall bear an engraved aluminum nameplate and shall be shipped in ISTA Certified Transit Tested Packaging.

**Wheel:** Wheel shall be a non-overloading design utilizing airfoil blades for maximum efficiency. The aluminum airfoil blades shall be welded to a spun aluminum dome. The dome shall be bolted to an aluminum hub assembly. The hub shall be keyed and locked to the fan shaft utilizing two setscrews. Wheel shall be balanced in accordance with AMCA Standard 204-05, Balance Quality and Vibration Levels for Fans.

**Motor** - Motor shall be NEMA Design B with Class B insulation rated for continuous duty and furnished at the specified voltage, phase and enclosure.

**Bearings:** Bearings shall be designed and tested specifically for use in air handling applications. Construction shall be heavy duty regreasable ball type in a cast iron housing selected for a minimum L50 life in excess of 200,000 hours at maximum cataloged operating speed.

**Belts and Drives:** Belts shall be oil and heat resistant, non-static type. Drives shall be precision machined cast iron type, keyed and securely attached to the wheel and motor shafts. Drives shall be sized for 150% of the installed motor horsepower. The variable pitch motor drive must be factory set to the specified fan RPM.

**Product:** Fan shall be model CVB as manufactured by Loren Cook Company of Springfield, Missouri.

**CVB Dimension Data**

Size	A	B	C	D	E	F Max.
12	12	17-1/8	19-1/8	9-15/16	1-5/16	11-1/4
14	14	19-1/8	22	11-7/16		
16	16	21-9/16	24-7/8	12-11/16		
18	18	24-1/2	27-3/4	14		
20	20	26-3/8	30-1/2	15-3/4	1-9/16	13-1/4
24	24	31-1/4	36-1/2	18-5/8		
28	28	36	42	21-1/2		
32	32	40-7/8	48	24-7/16		
36	36	44-1/4	53-3/8	26-3/4		15-1/2

Size	G	H	Wheel Diameter	Maximum Motor Frame	Thickness of Alum.	Approx. Ship. Wt. - lbs.
12	14-1/8	15-1/8	15-9/16	182T	.125	68
14	16-1/4	17-1/8	18-1/4			81
16	18-1/4	19-9/16	20-15/16	184T		93
18	20-3/8	22-1/2	23-9/16			175
20	22-1/2	24-3/8	26-1/4	213T		204
24	26-3/4	29-1/4	31-9/16	215T		279
28	30-3/4	34	36-7/8			381
32	35-3/16	38-7/8	42-3/16		495	
36	39-3/8	42-1/4	47-1/2		617	

All dimensions in inches. Weights in pounds, less motor.



## Centri-Vane® Stretch All Aluminum Mixed-Flow Fan Belt Drive

**Description:** Fan shall be a spun aluminum, duct mounted, belt driven mixed-flow fan.

**Certifications:** Fan shall be listed by Underwriters Laboratories (UL 705) and UL listed for Canada (cUL 705). Fan shall bear the AMCA Certified Ratings Seal for Air Performance.

**Construction:** The fan shall be bolted and welded construction utilizing corrosion resistant fasteners. The spun aluminum housing shall be constructed of minimum .125 thick marine alloy aluminum with inlet and outlet flanges. Straightening vanes shall be utilized for uniform airflow. Extended lube lines shall be furnished for lubrication of fan bearings. Aluminum adjustable motor mounting plate shall utilize threaded studs for positive belt tensioning. The adjustable mounting brackets shall be constructed of minimum .100 thick aluminum. Unit shall bear an engraved aluminum nameplate and shall be shipped in ISTA Certified Transit Tested Packaging.

**Wheel:** Wheel shall be a non-overloading design utilizing airfoil blades for maximum efficiency. The aluminum airfoil blades shall be welded to a spun aluminum dome. The dome shall be bolted to an aluminum hub assembly. The hub shall be keyed and securely attached to the fan shaft utilizing two set-screws. Wheel shall be balanced in accordance with AMCA Standard 204-05, Balance Quality and Vibration Levels for Fans.

**Motor** - Motor shall be NEMA Design B with Class B insulation rated for continuous duty and furnished at the specified voltage, phase and enclosure.

**Bearings:** Bearings shall be designed and tested specifically for use in air handling applications. Construction shall be heavy duty regreasable ball type in a cast iron housing selected for a minimum L50 life in excess of 200,000 hours at maximum cataloged operating speed.

**Belts and Drives:** Belts shall be oil and heat resistant, non-static type. Drives shall be precision machined cast iron type, keyed and securely attached to the wheel and motor shafts. Drives shall be sized for 150% of the installed motor horsepower. The variable pitch motor drive must be factory set to the specified fan RPM.

**Product:** Fan shall be model CV-S as manufactured by Loren Cook Company of Springfield, Missouri.



Loren Cook Company certifies that the CV-S shown herein is licensed to bear the AMCA Seal. The ratings shown are based on tests and procedures performed in accordance with AMCA Publication 211 and comply with the requirements of the AMCA Certified Ratings Program.



Model CV-S is furnished standard with UL 705 and cUL 705 listing (Power Ventilator/ZACT) when furnished with factory supplied motor.

### CV-S Dimension Data

Size	A	B	C	D	E	F	G	H
12	32-7/8	21-7/16	20-1/4	10-3/4	10-23/32	6-3/4	13-1/4	3-5/8
14	36	24-3/16	23	12-1/8	12-3/32	8-1/4	14-3/8	
16	39-9/16	27-9/16	26-1/8	13-13/16	13-25/32	10	14-1/2	4-1/8
18	43-5/8	30-7/16	29	15-1/4	15-7/32	11-1/2	15-5/8	
20	46-5/8	33-3/16	31-3/4	16-5/8	16-11/32	13	16-3/4	3-7/8
24	53-3/4	40	37-3/4	19-1/2	20	17	19	4-1/4
28	60-3/4	46	43-1/2	22-1/2	23	20	21	4-1/8
32	67-7/8	51	49-3/8	25-1/2	25-1/2	23	23-1/2	4-3/8
36	73-1/2	57	54-15/16	28-1/4	28-1/2	26	25-3/4	4-5/8

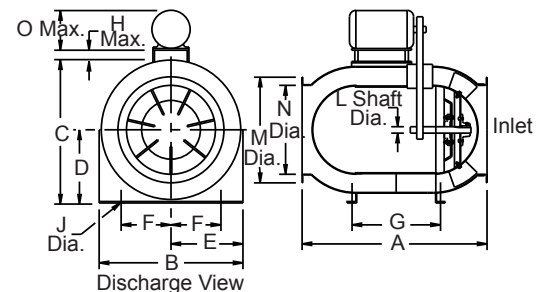

Size	J	L	M	N	O	Wheel Diameter	Max. Mtr. Frame	Approx. Ship. Wt. - lbs.	
12	9/16	1	14-5/8	12	9	15-9/16	182T	95	
14			16-5/8	14		18-1/4	184T	114	
16			18-5/8	16		20-15/16	213T	130	
18			20-5/8	18		23-9/16	213T	245	
20			22-5/8	20		26-1/4	213T	285	
24	11/16	1-3/16	27-1/8	24	10-1/2	31-9/16	215T	390	
28			31-1/8	28		36-7/8	254T	533	
32			35-1/8	32		42-3/16	256T	693	
36			1-15/16	39-1/8		36	47-1/2	256T	863

All dimensions in inches. Weights in pounds, less motor.

**Centri-Vane®**  
**All Aluminum**  
**Roof Mounted**  
**Upblast Mixed-Flow Fan**  
**Belt Drive**



Model UCV is furnished standard with UL 705 and cUL 705 listing (Power Ventilator/ZACT) when furnished with factory supplied motor.

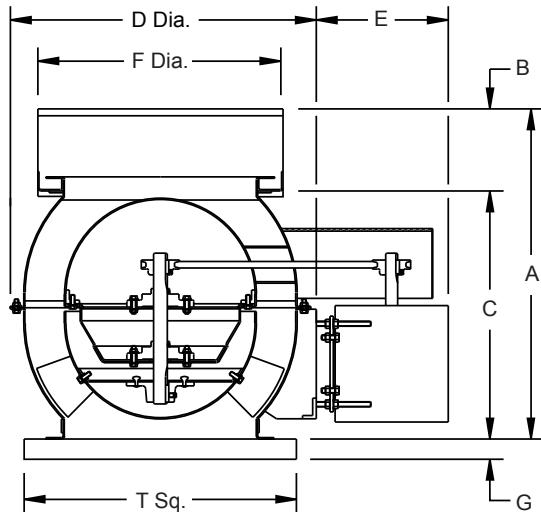

**Description:** Fan shall be a spun aluminum, belt driven, upblast mixed-flow fan.  
**Certifications:** Fan shall be listed by Underwriters Laboratories (UL 705) and UL listed for Canada (cUL 705).

**Construction:** The fan shall be bolted and welded construction utilizing corrosion resistant fasteners. The spun aluminum housing shall be constructed of minimum .125 thick marine alloy aluminum. Curb cap shall have continuously welded corners for maximum leak protection. Straightening vanes shall be utilized for uniform airflow. Extended lube lines shall be furnished for lubrication of fan bearings. Aluminum adjustable motor mounting plate shall utilize threaded studs for positive belt tensioning. Fan shall have hinged butterfly discharge dampers of aluminum or steel construction with a rain gutter to prevent rain infiltration. The damper assembly shall be protected by a continuously welded aluminum windband of minimum .064 thick aluminum. Unit shall bear an engraved aluminum nameplate and shall be shipped in ISTA Certified Transit Tested Packaging.

**Wheel:** Wheel shall be a non-overloading design utilizing airfoil blades for maximum efficiency. The aluminum airfoil blades shall be welded to a spun aluminum dome. The dome shall be bolted to an aluminum hub assembly. The hub shall be keyed and locked to the fan shaft utilizing two setscrews. Wheel shall be balanced in accordance with AMCA Standard 204-05, Balance Quality and Vibration Levels for Fans.

**Motor -** Motor shall be NEMA Design B with Class B insulation rated for continuous duty and furnished at the specified voltage, phase and enclosure.

**Bearings:** Bearings shall be designed and tested specifically for use in air handling applications. Construction shall be heavy duty regreasable ball type in a cast iron housing selected for a minimum L50 life in excess of 200,000 hours at maximum cataloged operating speed.

**Belts and Drives:** Belts shall be oil and heat resistant, non-static type. Drives shall be precision machined cast iron type, keyed and securely attached to the wheel and motor shafts. Drives shall be sized for 150% of the installed motor horsepower. The variable pitch motor drive must be factory set to the specified fan RPM.

**Product:** Fan shall be model UCV as manufactured by Loren Cook Company of Springfield, Missouri.

**UCV Dimension Data**

Size	A	B	C	D	E	F
12	25-1/8	9	17-1/8	19-1/8	15	16
14	29-1/8	10	19-1/8	22	16	18
16	31-9/16		21-9/16	24-7/8	17	21
18	36-1/2	12	24-1/2	27-3/4	19	23
20	38-1/2		26-1/2	30-1/2		25
24	45-3/8	14	31-3/8	36-1/2	21	29
28	52	16	36	42	29	33
32	58-7/8	18	40-7/8	48	30	37
36	64	20	44	53-3/8	32	41

Size	G	T	Shaft Diameter	Wheel Diameter	Material Thickness housing/base	Approx. Ship. Wt. - lbs.
12	2	20	1	15-9/16	.100/.100	98
14		24		18-1/4		121
16		28		20-15/16		143
18				23-9/16		208
20				26-1/4		274
24	3	32	1-3/16	31-9/16	.100/.125	369
28		36	1-11/16	36-7/8		491
32		42		42-3/16		625
36		48		1-15/16		47-1/2

All dimensions in inches. Weights in pounds, less motor. Drives through 5 H.P. are all variable pitch.

**Description:** Fan shall be a spun aluminum, hooded, roof mounted, belt driven, mixed-flow exhaust (or supply) fan.

**Certifications:** Fan shall be listed by Underwriters Laboratories (UL 705) and UL listed for Canada (cUL 705).

**Construction:** The fan shall be bolted and welded construction utilizing corrosion resistant fasteners. The spun aluminum housing shall be constructed of minimum .125 thick marine alloy aluminum with inlet and outlet flanges. The spun aluminum top cap shall be constructed of minimum .064 thick marine alloy aluminum, and the aluminum base shall have continuously welded curb cap corners for maximum leak protection. Straightening vanes shall be utilized for uniform airflow. Extended lube lines shall be furnished for lubrication of fan bearings. Aluminum adjustable motor mounting plate shall utilize threaded studs for positive belt tensioning. An aluminum weatherproof motor cover shall be standard. Unit shall bear an engraved aluminum nameplate and shall be shipped in ISTA Certified Transit Tested Packaging.

**Wheel:** Wheel shall be a non-overloading design utilizing airfoil blades for maximum efficiency. The aluminum airfoil blades shall be continuously welded to a spun aluminum dome. The dome shall be bolted to a cast or heavy gauge aluminum hub assembly. The hub shall be keyed and secured to the fan shaft with two set screws. Wheel shall be balanced in accordance with AMCA Standard 204-05, Balance Quality and Vibration Levels for Fans.

**Motor -** Motor shall be NEMA Design B with Class B insulation rated for continuous duty and furnished at the specified voltage, phase and enclosure.

**Bearings:** Bearings shall be designed and tested specifically for use in air handling applications. Construction shall be heavy duty regreasable ball type in a cast iron housing selected for a minimum L50 life in excess of 200,000 hours at maximum cataloged operating speed.

**Belts and Drives:** Belts shall be oil and heat resistant, non-static type. Drives shall be precision machined cast iron type, keyed and securely attached to the wheel and motor shafts. Drives shall be sized for 150% of the installed motor horsepower. The variable pitch motor drive must be factory set to the specified fan RPM.

**Product:** Fan shall be model CVR and CVR-S as manufactured by Loren Cook Company of Springfield, Missouri.

**Centri-Vane®  
All Aluminum  
Roof Mounted  
Mixed-Flow Fan  
Exhaust or Supply  
Belt Drive**



Model CVR and CVR-S are furnished standard with UL 705 and cUL 705 listing (Power Ventilator/ZACT) when furnished with factory supplied motor.

**CVR/CVR-S Dimension Data**

Size	A	B	C	D	E	F
12	22-1/8	5	17-1/8	19-1/8	15	27-15/16
14	24-1/8		19-1/8	22	16	
16	26-9/16		21-9/16	24-7/8	17	
18	29-1/2		24-1/2	27-3/4	19	
20	33-1/4	6-3/4	26-1/2	30-1/2	19	36
24	38-1/8		31-3/8	36-1/2	21	
28	44	8	36	42	29	42-1/8
32	57-7/8	17	40-7/8	48	30	52
36	61-1/2	17-1/2	44	53-3/8	32	62

Size	G	T	Shaft Diameter	Wheel Diameter	Material Thickness housing/base	Approx. Ship. Wt. - lbs.
12	2	20	1	15-9/16	.100/.100	98
14		24		18-1/4		121
16		28		20-15/16		143
18		32		23-9/16		208
20		36		26-1/4		274
24	3	32	1-3/16	31-9/16	.125/.125	369
28		36	1-11/16	36-7/8		491
32		42		42-3/16		625
36		48		47-1/2		767

All dimensions in inches. Weights in pounds, less motor. Drives through 5 H.P. are all variable pitch.

**Exhaust – CVR**

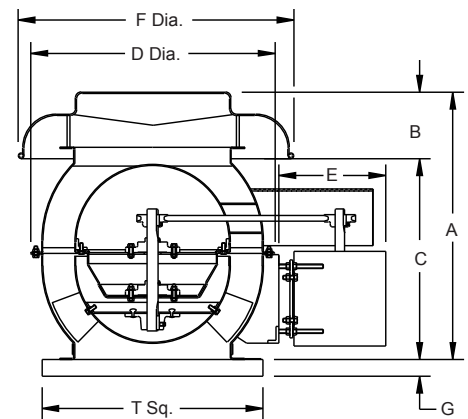

**Supply – CVR-S**

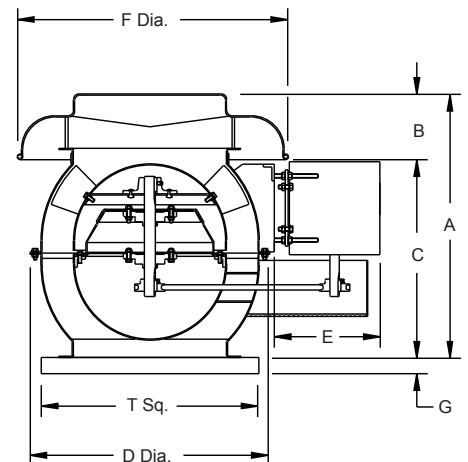

# ACCESSORIES

## Volume Control Damper

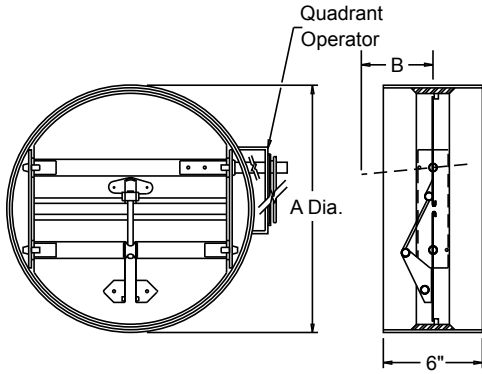

Size	Catalog Number	A Diameter	B Open Height
80	8	8	1-23/32
100	10	10	2
120	12	12	2-3/4
140	14	14	3-13/32
160	16	16	4-3/32
180	18	18	4-3/16
200	20	20	4-9/16
240	24	24	5-27/32
280	28	28	7-9/32
320	32	32	8-1/8
360	36	36	9-5/8

All dimensions in inches.

## Inlet Vane Damper

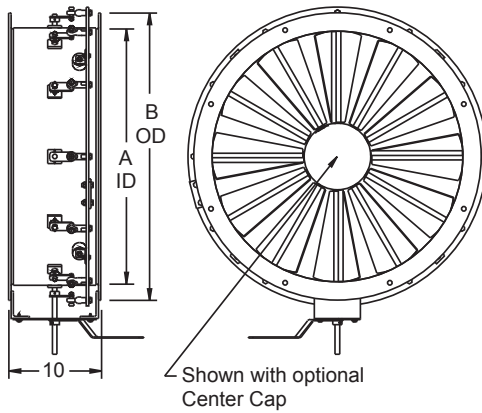

Size	A	B
12	12-1/4	14-5/8
14	14-1/4	16-5/8
16	16-1/4	18-5/8
18	18-1/4	20-5/8
20	20-1/4	22-5/8
24	24-1/4	26-3/4
28	28-1/4	30-3/4
32	32-1/4	34-3/4
36	36-1/4	38-3/4

All dimensions in inches.

## Flexible Duct Connector

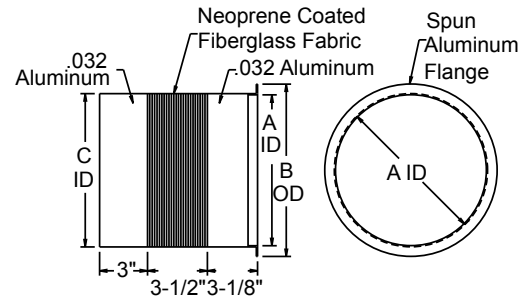

Size	A	B	C
8	8-3/16	10-11/16	8-1/2
10	10-3/16	12-11/16	10-1/2
12	12-3/16	14-11/16	12-1/2
14	14-3/16	16-11/16	14-1/2
16	16-3/16	18-11/16	16-1/2
18	18-3/16	20-11/16	18-1/2
20	20-3/16	22-11/16	20-1/2
24	24-3/16	27-3/16	24-1/2
28	28-3/16	31-3/16	28-1/2
32	32-3/16	35-3/16	32-1/2
36	36-3/16	39-3/16	36-1/2

All dimensions in inches.

## Companion Flange

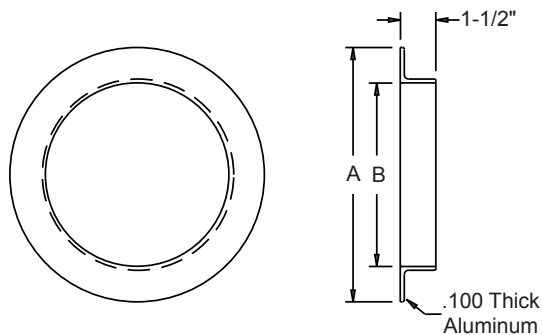

Size	A	B
8	10-11/16	8-3/16
10	12-11/16	10-3/16
12	14-11/16	12-3/16
14	16-11/16	14-3/16
16	8-11/16	16-3/16
18	20-11/16	18-3/16
20	22-11/16	20-3/16

All dimensions in inches.

Size	A	B
24	26-11/16	24-3/16
28	30-11/16	28-3/16
32	34-11/16	32-3/16
36	38-11/16	36-3/16

## Isolators

### Rubber-in-Shear- Ceiling Mounted

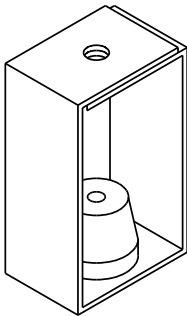

Unit	Rated Load
RC-75	75
RC-125	125
RC-175	175
RC-300	300

### Free Standing Spring - Floor Mounted

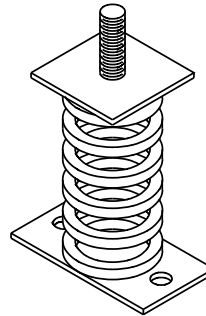

Unit	Rated Load	Spring. Rate (lbs./in.)
SF-70	70	51
SF-120	120	98
SF-220	220	196
SF-370	370	366

### Rubber-in-Shear - Floor Mounted

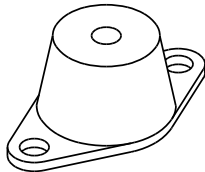

Unit	Rated Load
RF-55	55
RF-120	120
RF-220	220
RF-375	375

### Housed Spring - Floor Mounted

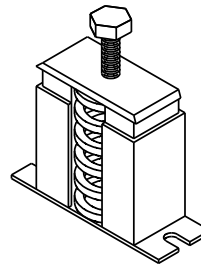

Unit	Rated Load	Spring. Rate (lbs./in.)
HF-120	120	98
HF-220	220	196
HF-320	320	302
HF-370	370	366

### Spring - Ceiling Mounted

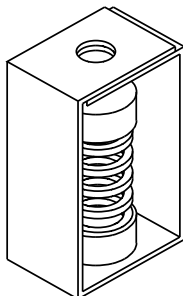

Unit	Rated Load	Spring. Rate (lbs./in.)
SC-35	35	23
SC-70	70	51
SC-125	125	100
SC-245	245	206
SC-370	370	370

### Restrained Spring - Floor Mounted

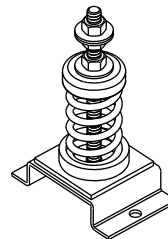

Unit	Rated Load	Spring. Rate (lbs./in.)
RS-70	70	51
RS-120	120	98
RS-220	220	196
RS-370	370	366

## Optional Coatings

**LORENIZED™** is an electrostatically applied, baked polyester powder coating. Each component shall be subject to a five stage environmentally friendly wash system, followed by a minimum 2 mil thick baked powder finish. Coating must exceed 1,000 hour salt spray under ASTM B117 test method.

**Cook Epoxy Powder** is an electrostatically applied, baked epoxy powder coating. Final coating thickness is 2.5 - 3.5 mils. For outdoor applications an optional UV resistant topcoat is available to prevent cosmetic chalking of the coating.

**Cook Phenolic Epoxy Powder** is an electrostatically applied, baked phenolic epoxy powder coating. Final coating thickness is 2 - 4 mils. For outdoor applications an optional UV resistant topcoat is required to prevent deterioration of the coating.

**Cook Easy Clean Powder** is an electrostatically applied, baked modified epoxy silicone powder producing a high temperature "non-stick" coating. Final coating thickness is 1.3 - 1.7 mils.

**Air Dry Phenolic (Heresite VR-504)** is a conventional spray applied phenolic resin coating. Final coating thickness is 4 - 6 mils. For outdoor applications an optional UV resistant topcoat (Heresite UC-5500) is required to prevent deterioration of the coating.

Refer to the corrosion resistance guide in the **Compute-A-Fan®** software for a listing of the coatings above and their resistance to a variety of chemicals. Additional special coatings are available.



# ACCESSORIES

## Disconnect Switches

**NEMA 1** - Indoor general purpose.

**NEMA 1 (Lockable)** - Indoor general purpose with locking capability.

**NEMA 3R** - Exterior mount, rain-tight.

**NEMA 4** - Watertight and dust-tight.

**NEMA 7 and NEMA 9** - Lockable, indoor, explosion proof.

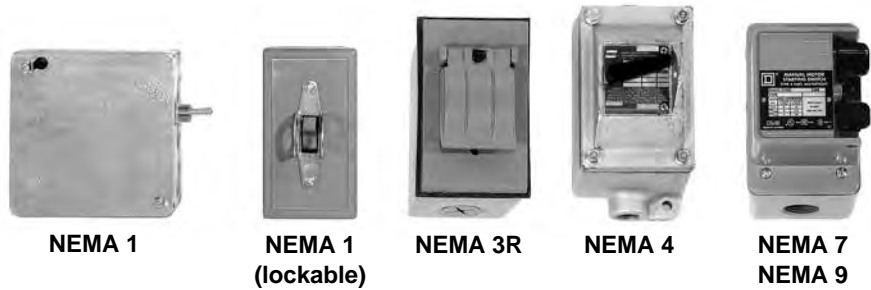

## RCG/RCA Roof Curb

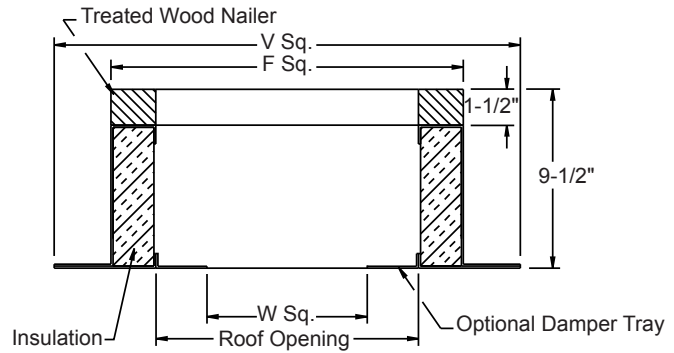

Size	Catalog Number		F Sq.	V Sq.	W Sq.	Roof Opening
	Galvanized	Aluminum				
12	RCG-18	RCA-18	18-1/2	22-1/2	11-3/4	15-1/2
14, 16	RCG-22	RCA-22	22-1/2	26-1/2	15-3/4	19-1/2
18, 20	RCG-26	RCA-26	26-1/2	30-1/2	19-3/4	23-1/2
24	RCG-30	RCA-30	30-1/2	34-1/2	23-3/4	27-1/2
28	RCG-34	RCA-34	34-1/2	38-1/2	27-3/4	31-1/2
32	RCG-40	RCA-40	40-1/2	44-1/2	33-3/4	37-1/2
36	RCG-46	RCA-46	46-1/2	50-1/2	39-3/4	43-1/2

All dimensions in inches.

## Additional Accessories:

- Safety Screen Inlet or Outlet
- Weather Cover
- Belt Guard

## Application Information (UCV)

### Minimum CFM to Open Dampers

Unit	CFM
12	769
14	1166
16	1662
18	2106
20	2601
24	3731
28	5086
32	6650
36	8483

**8-10 CVD**

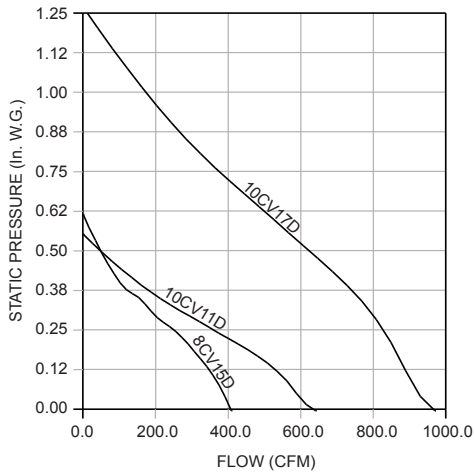

**12-14 CVD**

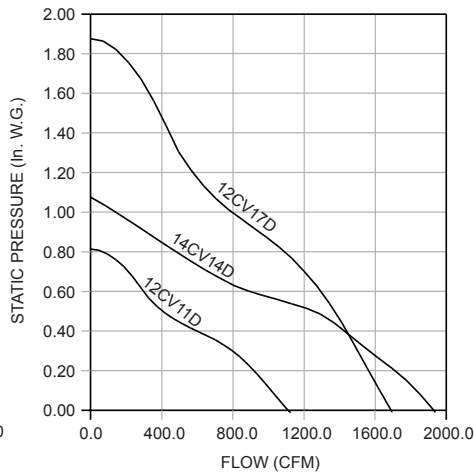

**14-16 CVD**

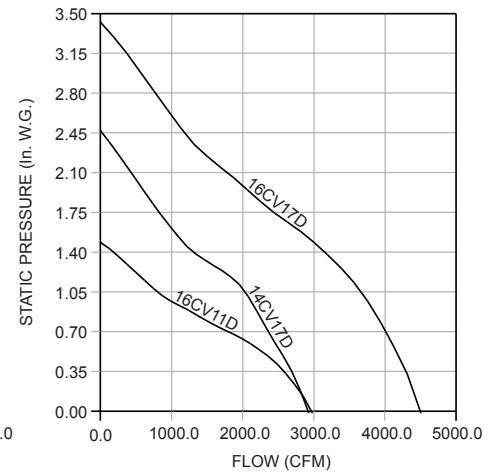

**18-20 CVD**

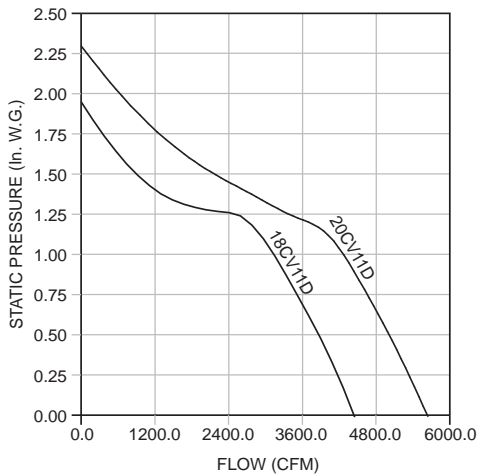

Catalog Number	Inlet/Outlet Dia.	Motor H.P.	Max. BHP	Fan RPM	CFM and Outlet Velocity vs. Static Pressure													
					1/8"		1/4"		3/8"		1/2"		5/8"		3/4"		7/8"	
					CFM	OV	CFM	OV	CFM	OV	CFM	OV	CFM	OV	CFM	OV	CFM	OV
8CV15D	8	1/20	.045	1550	350	1002	254	727	127	363	50	143						
10CV11D	10	1/12	.042	1140	536	983	367	673	188	345	52	95						
10CV17D		1/6	.149	1725	890	1632	834	1529	747	1370	628	1151	504	924	381	699	271	497
12CV11D	12	1/8	.101	1140	1002	1276	873	1112	671	854	424	540	282	359	162	206		
12CV17D		1/3	.357	1725	1617	2059	1538	1958	1456	1854	1371	1746	1278	1627	1152	1467	990	1261
14CV11D	14	1/4	.248	1140	1817	1700	1646	1540	1471	1376	1270	1188	839	785	581	543	365	341
14CV17D		1	.859	1725	2855	2671	2776	2597	2679	2506	2561	2396	2440	2283	2323	2173	2212	2069
16CV11D	16	1/2	.498	1140	2872	2057	2735	1959	2567	1839	2355	1687	2061	1476	1672	1198	1315	942
16CV17D		2	1.729	1725	4439	3180	4367	3128	4296	3077	4198	3007	4096	2934	3985	2855	3867	2770
18CV11D	18	1	.99	1140	4321	2462	4183	2383	4040	2302	3884	2213	3708	2112	3524	2008	3345	1906
20CV11D	20	1-1/2	1.602	1140	5477	2510	5328	2442	5174	2372	5011	2297	4839	2218	4660	2136	4476	2052

Catalog Number	Inlet/Outlet Dia.	Motor H.P.	Max. BHP	Fan RPM	CFM and Outlet Velocity vs. Static Pressure													
					1"		1-1/4"		1-1/2"		1-3/4"		2"		2-1/2"		3"	
					CFM	OV	CFM	OV	CFM	OV	CFM	OV	CFM	OV	CFM	OV	CFM	OV
8CV15D	8	1/20	.045	1550														
10CV11D	10	1/12	.042	1140														
10CV17D		1/6	.149	1725	176	328												
12CV11D	12	1/8	.101	1140														
12CV17D		1/3	.357	1725	811	1033	545	694	387	493	217	276						
14CV11D	14	1/4	.248	1140	151	141												
14CV17D		1	.859	1725	2100	1964	1705	1595	1159	1084	839	785	556	520				
16CV11D	16	1/2	.498	1140	953	683	469	336										
16CV17D		2	1.729	1725	3733	2674	3412	2444	2998	2148	2459	1762	1996	1430	1099	787	558	399
18CV11D	18	1	.99	1140	3150	1795	2594	1478	913	520	364	207						
20CV11D	20	1-1/2	1.602	1140	4278	1961	3454	1583	2231	1023	1319	605						

Performance certified is for installation type B- Free inlet, Ducted outlet. Power rating (BHP) does not include transmission losses. Performance does not include the effects of appurtenances (accessories). CFM based on fan inlet and outlet diameter. Inlet and outlet velocity are equal.

# 12-16 CVB Performance Data

## 12 CVB

**Inlet/Outlet Diameter** - 12"  
**Max. BHP** =  $0.069 \times (\text{RPM}/1000)^3$   
**Outlet Area** - 0.79 FT<sup>2</sup>  
**Outlet Velocity (FPM)** - CFM x 0.79  
**1140 RPM motor required**  
 on 950 and lower FRPM  
**3450 RPM motor required**  
 on 2649 and greater FRPM

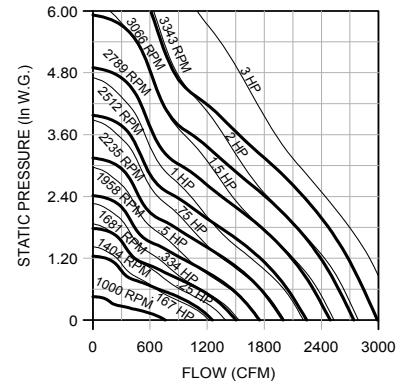
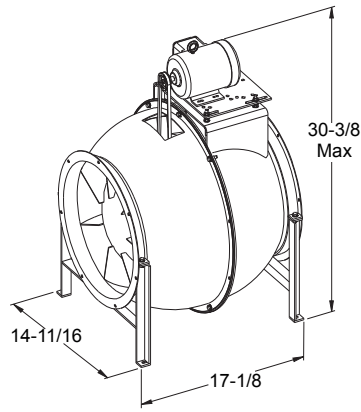

## 14 CVB

**Inlet/Outlet Diameter** - 14"  
**Max. BHP** =  $0.149 \times (\text{RPM}/1000)^3$   
**Outlet Area** - 1.07 FT<sup>2</sup>  
**Outlet Velocity (FPM)** - CFM x 1.07  
**1140 RPM motor required**  
 on 685 and lower FRPM  
**3450 RPM motor required**  
 on 2399 and greater FRPM

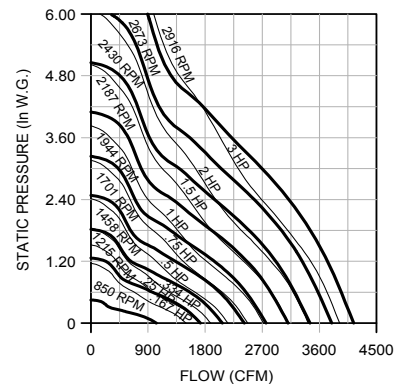
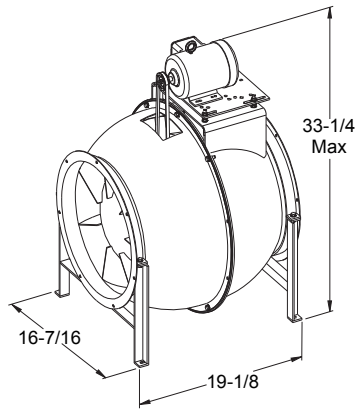

## 16 CVB

**Inlet/Outlet Diameter** - 16"  
**Max. BHP** =  $0.34 \times (\text{RPM}/1000)^3$   
**Outlet Area** - 1.40 FT<sup>2</sup>  
**Outlet Velocity (FPM)** - CFM x 1.40  
**1140 RPM motor required**  
 on 574 and lower FRPM  
**3450 RPM motor required**  
 on 2199 and greater FRPM

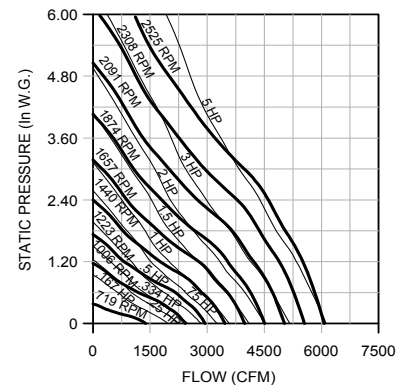
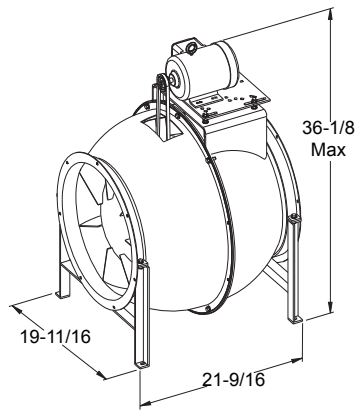

**12 CVB**

CFM	OV	Static Pressure															
		1/4" SP		1/2" SP		3/4" SP		1" SP		1-1/2" SP		2" SP		3" SP		4" SP	
		RPM	BHP	RPM	BHP	RPM	BHP	RPM	BHP	RPM	BHP	RPM	BHP	RPM	BHP	RPM	BHP
600	780	1000	.07	1263	.12	1466	.18	1641	.25	1949	.40	2196	.56	2569	.88	2856	1.21
700	910	1069	.08	1322	.15	1527	.22	1698	.28	1993	.44	2253	.61	2663	.99	2974	1.37
800	1040	1145	.10	1382	.18	1586	.25	1758	.33	2046	.49	2297	.67	2731	1.08	3069	1.52
900	1170	1227	.13	1448	.21	1644	.30	1817	.38	2104	.55	2349	.73	2779	1.16	3139	1.64
1000	1300	1315	.15	1519	.24	1706	.34	1876	.43	2165	.62	2407	.81	2824	1.24	3191	1.75
1100	1430	1407	.19	1595	.28	1772	.38	1936	.49	2224	.69	2467	.90	2876	1.34	3236	1.85
1200	1560	1503	.23	1675	.32	1842	.43	1999	.55	2282	.77	2527	1.00	2933	1.46	3283	1.97
1300	1690	1602	.27	1758	.37	1917	.49	2067	.61	2342	.86	2585	1.10	2993	1.59	3337	2.11
1400	1820	1704	.33	1847	.43	1995	.55	2138	.67	2404	.95	2644	1.21	3053	1.73		
1500	1950	1807	.39	1938	.49	2076	.61	2212	.75	2468	1.03	2704	1.32	3113	1.88		
1600	2080	1910	.46	2032	.56	2161	.69	2290	.83	2537	1.13	2765	1.44	3171	2.03		
1700	2210	2016	.54	2129	.64	2248	.77	2371	.92	2608	1.22	2829	1.55	3230	2.20		
1800	2340	2122	.63	2227	.73	2339	.86	2454	1.01	2682	1.33	2896	1.67	3289	2.36		
1900	2470	2227	.73	2328	.83	2432	.96	2541	1.12	2758	1.45	2966	1.80				
2000	2600	2336	.84	2430	.94	2527	1.08	2629	1.23	2837	1.57	3038	1.93				
2100	2730	2444	.96	2533	1.07	2625	1.20	2720	1.36	2918	1.71	3113	2.08				
2300	2990	2658	1.23	2740	1.35	2824	1.49	2909	1.64	3088	2.01	3268	2.40				
2500	3250	2878	1.57	2953	1.69	3027	1.82	3105	1.98	3266	2.35						
2700	3511	3099	1.96	3164	2.08	3235	2.22	3306	2.38								
2900	3771	3318	2.40														

**14 CVB**

CFM	OV	Static Pressure															
		1/4" SP		1/2" SP		3/4" SP		1" SP		1-1/2" SP		2" SP		3" SP		4" SP	
		RPM	BHP	RPM	BHP	RPM	BHP	RPM	BHP	RPM	BHP	RPM	BHP	RPM	BHP	RPM	BHP
800	748	850	.09	1077	.17	1251	.24	1402	.33	1665	.53	1875	.75	2191	1.18	2436	1.62
925	865	904	.11	1123	.20	1298	.28	1445	.37	1701	.58	1923	.82	2269	1.32	2531	1.82
1050	982	962	.13	1170	.23	1345	.33	1492	.43	1741	.64	1959	.89	2327	1.44	2610	2.01
1175	1099	1025	.16	1220	.27	1391	.38	1539	.49	1786	.71	1997	.96	2369	1.54	2671	2.17
1300	1216	1093	.19	1275	.31	1439	.43	1586	.56	1833	.80	2041	1.05	2404	1.64	2718	2.31
1425	1333	1164	.23	1332	.35	1489	.49	1632	.62	1880	.89	2088	1.16	2441	1.75	2754	2.44
1550	1449	1238	.27	1393	.40	1542	.55	1680	.70	1926	.99	2135	1.27	2484	1.89	2789	2.58
1675	1566	1314	.32	1457	.46	1599	.61	1731	.77	1973	1.09	2182	1.40	2530	2.03	2829	2.74
1800	1683	1393	.38	1524	.52	1658	.68	1785	.85	2020	1.20	2228	1.53	2578	2.20	2872	2.92
1925	1800	1473	.45	1594	.59	1719	.76	1842	.93	2069	1.30	2275	1.67	2625	2.38		
2050	1917	1555	.53	1666	.67	1783	.84	1900	1.02	2120	1.41	2321	1.81	2672	2.57		
2175	2034	1636	.62	1741	.76	1850	.93	1961	1.12	2174	1.53	2370	1.95	2718	2.76		
2300	2151	1719	.72	1817	.86	1919	1.04	2025	1.23	2229	1.65	2420	2.10	2764	2.97		
2425	2268	1803	.83	1894	.97	1991	1.15	2090	1.35	2287	1.78	2473	2.25	2811	3.18		
2550	2385	1885	.95	1973	1.09	2064	1.27	2158	1.48	2346	1.92	2527	2.40				
2675	2502	1970	1.08	2053	1.23	2139	1.41	2227	1.62	2408	2.08	2583	2.57				
2800	2619	2056	1.23	2133	1.38	2215	1.56	2299	1.77	2471	2.24	2640	2.74				
3050	2853	2225	1.56	2297	1.72	2370	1.90	2446	2.11	2602	2.60	2760	3.13				
3300	3086	2395	1.95	2463	2.12	2530	2.30	2598	2.51	2741	3.02						
3550	3320	2569	2.41	2629	2.57	2692	2.77	2754	2.98								

**16 CVB**

CFM	OV	Static Pressure															
		1/4" SP		1/2" SP		3/4" SP		1" SP		1-1/2" SP		2" SP		3" SP		4" SP	
		RPM	BHP	RPM	BHP	RPM	BHP	RPM	BHP	RPM	BHP	RPM	BHP	RPM	BHP	RPM	BHP
1100	794	719	.12	920	.23	1069	.34	1195	.45	1408	.68	1587	.96	1884	1.58	2127	2.27
1300	938	763	.15	964	.27	1116	.40	1242	.53	1453	.79	1632	1.07	1933	1.72	2183	2.46
1500	1083	819	.19	1006	.32	1161	.46	1289	.62	1499	.92	1677	1.22	1979	1.89	2232	2.65
1700	1227	883	.23	1048	.38	1204	.54	1334	.70	1546	1.05	1724	1.39	2023	2.08	2277	2.86
1900	1371	947	.29	1095	.44	1245	.62	1377	.80	1593	1.17	1771	1.56	2069	2.32	2322	3.12
2100	1516	1010	.35	1152	.52	1287	.70	1418	.90	1638	1.30	1818	1.73	2115	2.57	2367	3.41
2300	1660	1077	.42	1216	.61	1334	.79	1460	1.01	1681	1.44	1863	1.89	2162	2.83	2413	3.75
2500	1805	1147	.50	1280	.71	1390	.90	1503	1.12	1722	1.59	1907	2.07	2209	3.09	2460	4.10
2700	1949	1221	.60	1343	.82	1451	1.03	1552	1.25	1763	1.76	1950	2.26	2256	3.33	2507	4.44
2900	2093	1296	.72	1405	.94	1515	1.18	1608	1.40	1805	1.92	1991	2.47	2301	3.59		
3100	2238	1372	.84	1471	1.07	1579	1.34	1670	1.58	1849	2.09	2032	2.68	2344	3.85		
3300	2382	1450	.99	1539	1.22	1642	1.50	1734	1.77	1899	2.29	2074	2.91	2387	4.15		
3500	2527	1528	1.15	1610	1.39	1705	1.67	1798	1.98	1955	2.51	2117	3.13	2428	4.45		
3700	2671	1607	1.34	1682	1.58	1769	1.86	1862	2.19	2015	2.76	2164	3.37	2469	4.78		
3900	2815	1686	1.53	1756	1.79	1836	2.07	1924	2.41	2078	3.04	2217	3.65	2510	5.10		
4300	3104	1846	2.00	1908	2.28	1976	2.57	2052	2.90	2207	3.66	2336	4.31				
4700	3393	2008	2.55	2063	2.85	2123	3.17	2188	3.50	2333	4.31	2463	5.08				
5100	3682	2170	3.21	2220	3.53	2274	3.86	2330	4.21	2459	5.01						
5500	3971	2333	3.97	2379	4.31	2427	4.67	2478	5.03								
5900	4259	2496	4.84														

Performance certified is for installation type B - Free inlet, Ducted outlet. Power rating (BHP) does not include transmission losses. Performance does not include the effects of appurtenances (accessories).

# 18-24 CVB Performance Data

## 18 CVB

Inlet/Outlet Diameter - 18"  
 Max. BHP =  $0.613 \times (\text{RPM}/1000)^3$   
 Outlet Area - 1.77 FT<sup>2</sup>  
 Outlet Velocity (FPM) - CFM x 1.77  
 1140 RPM motor required  
 on 527 and lower FRPM

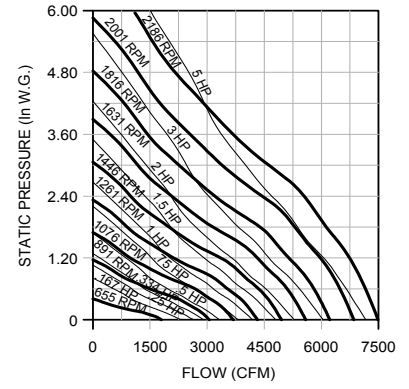
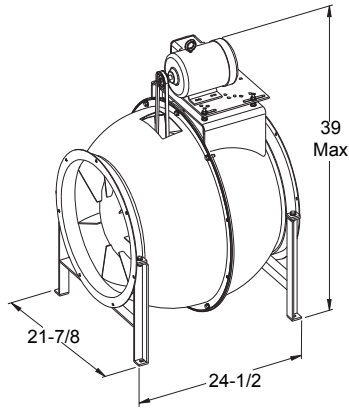

## 20 CVB

Inlet/Outlet Diameter - 20"  
 Max. BHP =  $0.992 \times (\text{RPM}/1000)^3$   
 Outlet Area - 2.18 FT<sup>2</sup>  
 Outlet Velocity (FPM) - CFM x 2.18  
 1140 RPM motor required  
 on 492 and lower FRPM

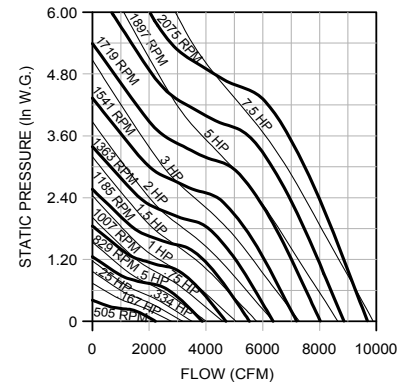
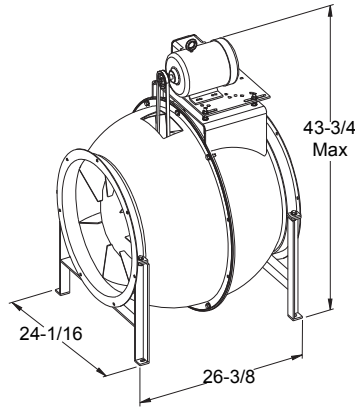

## 24 CVB

Inlet/Outlet Diameter - 24"  
 Max. BHP =  $2.62 \times (\text{RPM}/1000)^3$   
 Outlet Area - 3.14 FT<sup>2</sup>  
 Outlet Velocity (FPM) - CFM x 3.14  
 1140 RPM motor required  
 on 381 and lower FRPM

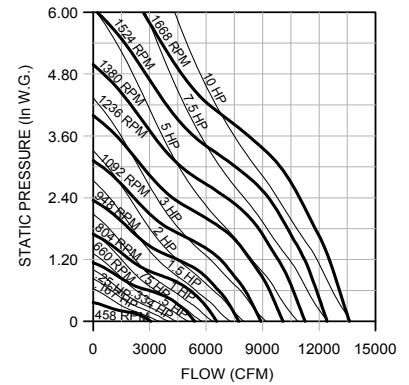
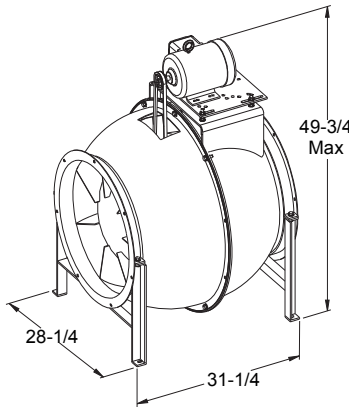



**18 CVB**

CFM	OV	Static Pressure															
		1/4" SP		1/2" SP		3/4" SP		1" SP		1-1/2" SP		2" SP		3" SP		4" SP	
		RPM	BHP	RPM	BHP	RPM	BHP	RPM	BHP	RPM	BHP	RPM	BHP	RPM	BHP	RPM	BHP
1500	845	655	.17	835	.31	968	.46	1080	.61	1268	.92	1428	1.27	1694	2.08	1912	2.97
1750	985	698	.21	873	.37	1009	.54	1121	.72	1308	1.07	1467	1.43	1735	2.26	1959	3.21
2000	1126	751	.26	909	.44	1048	.62	1162	.82	1350	1.23	1507	1.63	1774	2.48	2000	3.46
2250	1267	807	.32	947	.51	1084	.72	1201	.93	1391	1.39	1548	1.84	1814	2.75	2040	3.75
2500	1408	862	.39	991	.59	1121	.82	1238	1.06	1431	1.54	1590	2.06	1854	3.05	2079	4.08
2750	1549	919	.47	1044	.69	1158	.93	1274	1.19	1470	1.71	1631	2.26	1895	3.38	2119	4.47
3000	1690	979	.56	1100	.81	1202	1.05	1310	1.33	1507	1.89	1670	2.47	1937	3.70	2160	4.90
3250	1830	1042	.68	1157	.95	1253	1.19	1350	1.47	1543	2.09	1709	2.70	1978	4.01		
3500	1971	1106	.81	1212	1.09	1308	1.37	1395	1.64	1579	2.29	1745	2.95	2018	4.32		
3750	2112	1173	.96	1267	1.23	1365	1.56	1447	1.84	1616	2.50	1782	3.21	2057	4.64		
4000	2253	1241	1.12	1326	1.41	1421	1.76	1501	2.06	1656	2.72	1818	3.49	2095	4.98		
4250	2394	1309	1.31	1386	1.60	1476	1.96	1558	2.32	1702	2.97	1854	3.76	2132	5.36		
4500	2535	1378	1.52	1449	1.82	1531	2.18	1614	2.58	1752	3.26	1893	4.04				
4750	2676	1447	1.75	1513	2.07	1588	2.42	1670	2.85	1806	3.59	1936	4.36				
5000	2816	1517	2.01	1578	2.34	1647	2.70	1724	3.13	1862	3.95	1983	4.71				
5250	2957	1587	2.29	1645	2.64	1709	3.00	1780	3.43	1918	4.32	2035	5.11				
5500	3098	1658	2.61	1711	2.96	1772	3.34	1837	3.75	1975	4.72						
6000	3380	1799	3.31	1848	3.69	1900	4.09	1958	4.52								
6500	3661	1942	4.14	1986	4.55	2033	4.97	2083	5.41								
7000	3943	2085	5.10														

**20 CVB**

CFM	OV	Static Pressure															
		1/4" SP		1/2" SP		3/4" SP		1" SP		1-1/2" SP		2" SP		3" SP		4" SP	
		RPM	BHP	RPM	BHP	RPM	BHP	RPM	BHP	RPM	BHP	RPM	BHP	RPM	BHP	RPM	BHP
1500	692	505	.13	677	.27	808	.43	918	.59	1098	.95	1243	1.35	1479	2.23	1677	3.23
1850	853	551	.16	693	.32	830	.49	940	.69	1126	1.10	1279	1.53	1523	2.48	1723	3.54
2200	1015	606	.22	723	.37	846	.57	962	.77	1147	1.23	1304	1.72	1560	2.76	1766	3.89
2550	1176	665	.28	770	.45	870	.65	977	.87	1170	1.37	1325	1.90	1587	3.04	1802	4.26
2900	1338	729	.36	823	.54	911	.75	1000	.98	1188	1.51	1348	2.08	1609	3.33	1830	4.64
3250	1499	794	.46	879	.65	961	.87	1040	1.12	1203	1.66	1367	2.26	1631	3.59	1852	5.02
3600	1661	861	.57	940	.79	1015	1.02	1088	1.27	1229	1.83	1381	2.46	1654	3.86	1874	5.39
3950	1822	929	.71	1003	.94	1072	1.19	1140	1.45	1270	2.03	1402	2.68	1673	4.13	1896	5.73
4300	1984	999	.87	1067	1.12	1132	1.38	1195	1.65	1316	2.25	1435	2.92	1687	4.43	1918	6.09
4650	2145	1068	1.05	1133	1.33	1194	1.60	1253	1.89	1367	2.51	1478	3.20	1704	4.75	1936	6.47
5000	2307	1139	1.26	1200	1.56	1258	1.86	1313	2.15	1421	2.79	1525	3.50	1730	5.09	1950	6.86
5350	2468	1210	1.50	1268	1.81	1323	2.13	1375	2.45	1477	3.12	1576	3.84	1767	5.47	1966	7.28
5700	2630	1281	1.76	1337	2.10	1389	2.44	1439	2.78	1536	3.48	1629	4.22	1810	5.88	1991	7.73
6050	2791	1353	2.06	1406	2.42	1456	2.79	1503	3.14	1596	3.87	1685	4.64	1857	6.33	2026	8.23
6400	2953	1425	2.40	1475	2.77	1523	3.16	1569	3.54	1657	4.30	1743	5.10	1907	6.82		
6750	3114	1497	2.77	1546	3.17	1592	3.57	1636	3.98	1720	4.78	1802	5.60	1960	7.37		
7100	3276	1570	3.18	1617	3.60	1661	4.02	1703	4.44	1784	5.29	1862	6.14	2014	7.95		
7800	3599	1716	4.13	1759	4.58	1799	5.03	1839	5.50	1915	6.44	1987	7.36				
8500	3922	1863	5.26	1902	5.74	1940	6.23	1977	6.74	2048	7.76						
9200	4245	2009	6.56	2046	7.09	2082	7.62										

**24 CVB**

CFM	OV	Static Pressure															
		1/4" SP		1/2" SP		3/4" SP		1" SP		1-1/2" SP		2" SP		3" SP		4" SP	
		RPM	BHP	RPM	BHP	RPM	BHP	RPM	BHP	RPM	BHP	RPM	BHP	RPM	BHP	RPM	BHP
2500	804	458	.24	593	.46	699	.68	785	.92	923	1.40	1037	1.92	1227	3.06	1387	4.32
2950	948	488	.30	615	.55	721	.81	811	1.08	954	1.63	1071	2.21	1262	3.44	1422	4.79
3400	1093	526	.38	639	.65	743	.95	833	1.25	982	1.87	1101	2.50	1296	3.85	1456	5.28
3850	1238	568	.48	667	.76	766	1.09	854	1.42	1005	2.11	1129	2.82	1328	4.28	1491	5.83
4300	1383	612	.59	700	.90	791	1.25	877	1.62	1026	2.36	1153	3.14	1358	4.74	1523	6.40
4750	1527	657	.71	738	1.05	819	1.42	901	1.82	1047	2.63	1175	3.48	1385	5.21	1554	7.00
5200	1672	704	.86	780	1.24	852	1.61	927	2.03	1070	2.92	1196	3.83	1409	5.70	1582	7.62
5650	1817	753	1.04	823	1.44	889	1.84	957	2.27	1094	3.22	1218	4.20	1431	6.19	1608	8.25
6100	1962	804	1.26	867	1.66	930	2.10	991	2.54	1119	3.53	1241	4.59	1452	6.71	1632	8.91
6550	2106	855	1.50	912	1.91	972	2.39	1029	2.85	1147	3.87	1265	4.99	1473	7.24	1654	9.58
7000	2251	907	1.78	958	2.19	1016	2.71	1070	3.20	1178	4.24	1290	5.41	1495	7.80	1675	10.30
7450	2396	960	2.10	1006	2.51	1060	3.04	1112	3.58	1212	4.65	1317	5.84	1519	8.40	1695	11.00
7900	2541	1013	2.45	1055	2.88	1104	3.40	1155	3.99	1250	5.11	1347	6.32	1542	8.99		
8350	2685	1066	2.83	1105	3.28	1150	3.81	1199	4.43	1290	5.61	1380	6.84	1567	9.61		
8800	2830	1119	3.26	1156	3.74	1197	4.26	1243	4.89	1332	6.17	1416	7.42	1593	10.30		
9700	3119	1226	4.23	1260	4.79	1295	5.32	1334	5.94	1418	7.37	1495	8.74				
10600	3409	1333	5.38	1365	6.03	1396	6.59	1429	7.20	1505	8.70	1579	10.20				
11500	3698	1441	6.73	1470	7.45	1499	8.09	1528	8.71	1595	10.20						
12400	3988	1549	8.31	1577	9.12	1604	9.83	1630	10.50								
13300	4277	1657	10.10	1684	11.00												

Performance certified is for installation type B - Free inlet, Ducted outlet. Power rating (BHP) does not include transmission losses. Performance does not include the effects of appurtenances (accessories).

# 28-36 CVB Performance Data

## 28 CVB

**Inlet/Outlet Diameter** - 28"  
**Max. BHP** =  $5.69 \times (\text{RPM}/1000)^3$   
**Outlet Area** - 4.28 FT<sup>2</sup>  
**Outlet Velocity (FPM)** - CFM x 4.28  
**1140 RPM motor required**  
**on 402 and lower FRPM**

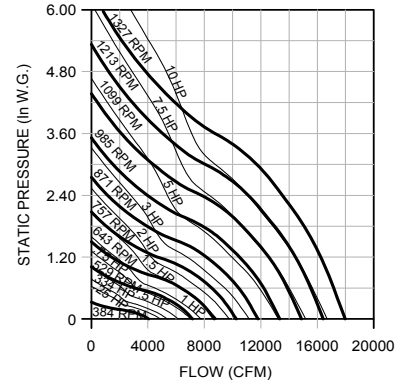
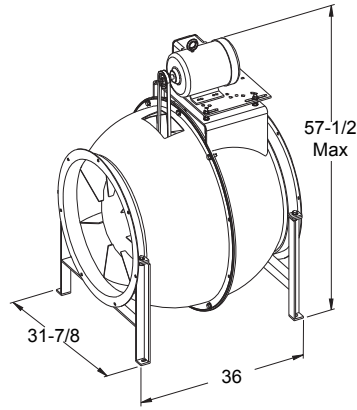

## 32 CVB

**Inlet/Outlet Diameter** - 32"  
**Max. BHP** =  $10.52 \times (\text{RPM}/1000)^3$   
**Outlet Area** - 4.28 FT<sup>2</sup>  
**Outlet Velocity (FPM)** - CFM x 5.59  
**1140 RPM motor required**  
**on 402 and lower FRPM**

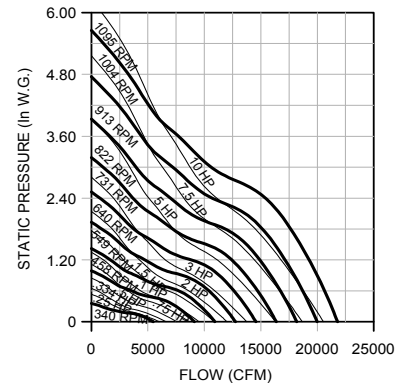
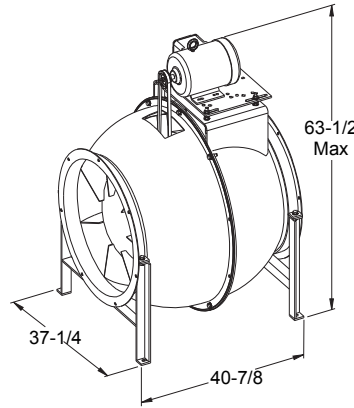

## 36 CVB

**Inlet/Outlet Diameter** - 36"  
**Max. BHP** =  $5.69 \times (\text{RPM}/1000)^3$   
**Outlet Area** - 7.07 FT<sup>2</sup>  
**Outlet Velocity (FPM)** - CFM x 7.07  
**1140 RPM motor required**  
**on 389 and lower FRPM**

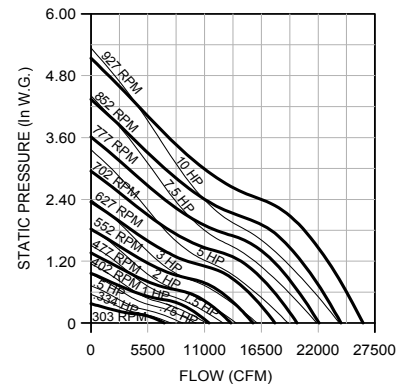
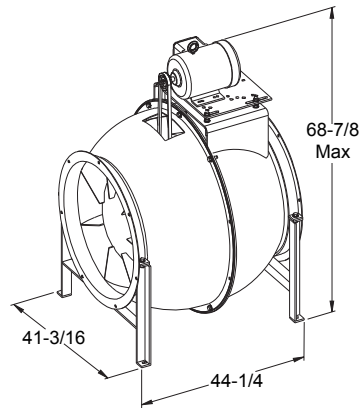

**28 CVB**

CFM	OV	Static Pressure															
		1/4" SP		1/2" SP		3/4" SP		1" SP		1-1/2" SP		2" SP		3" SP		4" SP	
		RPM	BHP	RPM	BHP	RPM	BHP	RPM	BHP	RPM	BHP	RPM	BHP	RPM	BHP	RPM	BHP
3400	802	384	.32	498	.66	590	1.00	665	1.31	788	1.95	891	2.68	1063	4.37	1207	6.29
3925	926	407	.38	512	.73	604	1.15	681	1.54	806	2.25	910	3.00	1083	4.74	1228	6.74
4450	1050	433	.46	529	.82	617	1.26	695	1.74	823	2.60	928	3.40	1102	5.17	1247	7.21
4975	1174	460	.55	550	.93	632	1.38	708	1.90	839	2.94	946	3.86	1120	5.69	1266	7.76
5500	1297	488	.66	573	1.06	650	1.52	722	2.04	853	3.23	962	4.32	1138	6.31	1285	8.42
6025	1421	519	.79	598	1.22	670	1.69	739	2.22	865	3.46	977	4.76	1156	7.00	1303	9.18
6550	1545	551	.94	625	1.39	693	1.88	758	2.42	879	3.68	990	5.11	1173	7.71	1321	10.10
7075	1669	584	1.11	652	1.58	718	2.10	779	2.65	895	3.92	1002	5.39	1188	8.37		
7600	1793	618	1.31	681	1.79	744	2.34	802	2.92	913	4.20	1017	5.70	1202	8.97		
8125	1917	653	1.55	710	2.03	771	2.61	827	3.21	932	4.51	1032	6.00	1214	9.45		
8650	2041	688	1.80	741	2.30	798	2.89	853	3.53	953	4.86	1050	6.37	1227	9.90		
9175	2165	724	2.09	773	2.60	826	3.20	879	3.86	976	5.25	1069	6.78	1241	10.30		
9700	2289	761	2.42	806	2.94	855	3.54	906	4.23	1001	5.68	1089	7.22	1257	10.80		
10225	2412	797	2.78	840	3.31	886	3.93	934	4.63	1026	6.13	1111	7.72				
10750	2536	834	3.17	874	3.72	917	4.35	963	5.07	1052	6.62	1134	8.24				
11800	2784	909	4.10	944	4.66	982	5.31	1023	6.05	1106	7.70	1184	9.43				
12850	3032	983	5.16	1016	5.78	1050	6.46	1086	7.21	1161	8.89	1237	10.80				
13900	3280	1058	6.42	1088	7.08	1119	7.78	1152	8.56	1220	10.30						
14950	3528	1135	7.92	1162	8.59	1190	9.32	1219	10.10								
16000	3775	1211	9.60	1236	10.30												

**32 CVB**

CFM	OV	Static Pressure															
		1/4" SP		1/2" SP		3/4" SP		1" SP		1-1/2" SP		2" SP		3" SP		4" SP	
		RPM	BHP	RPM	BHP	RPM	BHP	RPM	BHP	RPM	BHP	RPM	BHP	RPM	BHP	RPM	BHP
4400	793	340	.40	449	.84	524	1.26	586	1.69	693	2.63	784	3.67	929	5.86	1049	8.24
5050	911	356	.47	461	.95	541	1.44	604	1.93	709	2.93	800	4.04	951	6.46	1072	8.99
5700	1028	376	.56	472	1.05	556	1.62	622	2.18	726	3.26	815	4.42	968	7.00	1094	9.78
6350	1145	399	.67	483	1.16	568	1.78	637	2.41	745	3.64	832	4.86	983	7.54		
7000	1263	425	.80	499	1.30	578	1.94	650	2.64	762	4.01	850	5.34	998	8.12		
7650	1380	451	.95	518	1.46	589	2.10	660	2.84	778	4.37	869	5.86	1016	8.80		
8300	1497	478	1.12	540	1.66	604	2.30	671	3.06	791	4.70	885	6.33	1034	9.51		
8950	1614	507	1.32	564	1.88	622	2.53	683	3.28	802	5.02	900	6.80	1052	10.30		
9600	1732	535	1.54	589	2.13	642	2.78	698	3.54	813	5.35	914	7.26	1070	11.00		
10250	1849	564	1.79	614	2.40	664	3.08	715	3.83	823	5.65	925	7.68				
10900	1966	594	2.08	641	2.72	688	3.42	735	4.18	835	5.99	935	8.09				
11550	2084	624	2.40	668	3.06	713	3.79	757	4.56	850	6.38	946	8.53				
12200	2201	654	2.74	696	3.44	738	4.18	780	4.99	866	6.80	957	8.95				
12850	2318	685	3.13	725	3.86	765	4.64	804	5.45	885	7.28	970	9.43				
14150	2553	746	4.01	782	4.79	819	5.64	855	6.50	927	8.38	1002	10.50				
14800	2670	777	4.51	812	5.34	847	6.20	881	7.09	950	9.01						
16100	2905	840	5.66	871	6.53	903	7.44	935	8.40	999	10.40						
17400	3139	903	6.99	932	7.93	961	8.89	991	9.92								
18700	3374	966	8.52	993	9.52	1020	10.50										
20000	3608	1029	10.30														

**36 CVB**

CFM	OV	Static Pressure															
		1/4" SP		1/2" SP		3/4" SP		1" SP		1-1/2" SP		2" SP		3" SP		4" SP	
		RPM	BHP	RPM	BHP	RPM	BHP	RPM	BHP	RPM	BHP	RPM	BHP	RPM	BHP	RPM	BHP
5600	792	303	.52	398	1.06	466	1.60	522	2.16	614	3.32	691	4.56	820	7.30		
6325	894	314	.59	409	1.20	479	1.80	536	2.42	628	3.67	706	5.02	835	7.90		
7050	997	330	.69	418	1.32	491	2.01	549	2.68	643	4.07	721	5.51	850	8.55		
7775	1099	347	.80	426	1.43	501	2.20	561	2.95	657	4.46	735	5.99	865	9.24		
8500	1202	367	.94	437	1.57	510	2.39	572	3.22	670	4.86	749	6.51	880	9.97		
9225	1304	387	1.09	450	1.74	518	2.56	582	3.48	682	5.25	763	7.04	894	10.70		
9950	1407	408	1.27	466	1.93	528	2.75	590	3.71	694	5.66	776	7.58				
10675	1510	429	1.46	483	2.15	539	2.96	599	3.95	704	6.05	788	8.10				
11400	1612	452	1.69	502	2.41	553	3.22	608	4.20	714	6.44	800	8.66				
12125	1715	474	1.94	521	2.68	569	3.52	619	4.48	722	6.79	810	9.16				
12850	1817	497	2.22	542	3.00	586	3.84	633	4.82	731	7.16	820	9.69				
13575	1920	520	2.52	562	3.32	605	4.22	648	5.20	740	7.52	829	10.20				
14300	2022	543	2.85	584	3.70	624	4.61	664	5.60	750	7.91	838	10.70				
15025	2125	567	3.23	605	4.09	643	5.03	682	6.06	762	8.37						
15750	2228	591	3.64	627	4.53	664	5.51	700	6.54	775	8.85						
17200	2433	639	4.56	672	5.51	706	6.56	739	7.64	806	10.00						
18650	2638	688	5.65	718	6.66	749	7.75	780	8.91								
20100	2843	736	6.87	764	7.95	793	9.12	822	10.30								
21550	3048	786	8.33	812	9.47	838	10.70										
23000	3253	835	9.94														

Performance certified is for installation type B - Free inlet, Ducted outlet. Power rating (BHP) does not include transmission losses. Performance does not include the effects of appurtenances (accessories).

## 12 CV-S

**Inlet/Outlet Diameter** - 12"  
**Max. BHP** =  $0.69 \times (\text{RPM}/1000)^3$   
**Outlet Area** - 0.79 FT<sup>2</sup>  
**Outlet Velocity (FPM)** - CFM x 0.79  
**1140 RPM motor required**  
 on 851 and lower FRPM  
**3450 RPM motor required**  
 on 2649 and greater FRPM

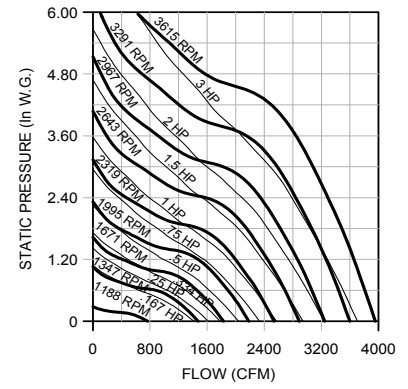
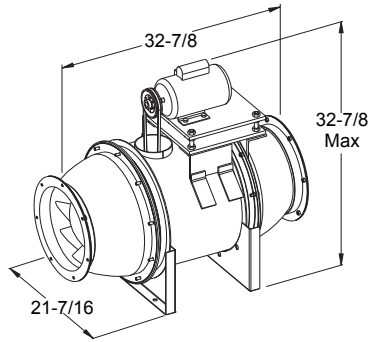

## 14 CV-S

**Inlet/Outlet Diameter** - 14"  
**Max. BHP** =  $0.149 \times (\text{RPM}/1000)^3$   
**Outlet Area** - 1.07 FT<sup>2</sup>  
**Outlet Velocity (FPM)** - CFM x 1.07  
**1140 RPM motor required**  
 on 650 and lower FRPM  
**3450 RPM motor required**  
 on 2599 and greater FRPM

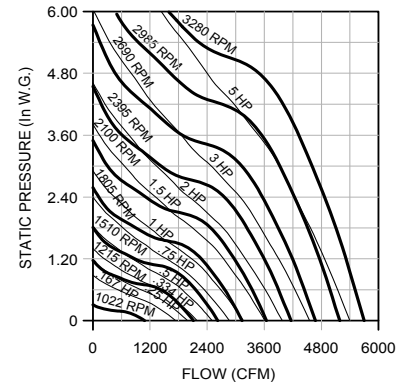
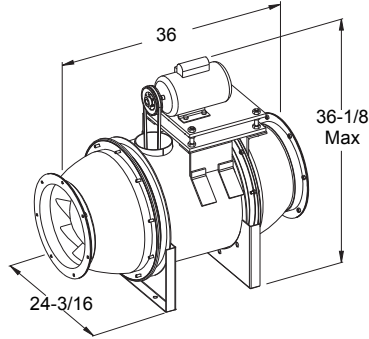

## 16 CV-S

**Inlet/Outlet Diameter** - 16"  
**Max. BHP** =  $0.34 \times (\text{RPM}/1000)^3$   
**Outlet Area** - 1.40 FT<sup>2</sup>  
**Outlet Velocity (FPM)** - CFM x 1.40  
**1140 RPM motor required**  
 on 574 and lower FRPM  
**3450 RPM motor required**  
 on 2249 and greater FRPM

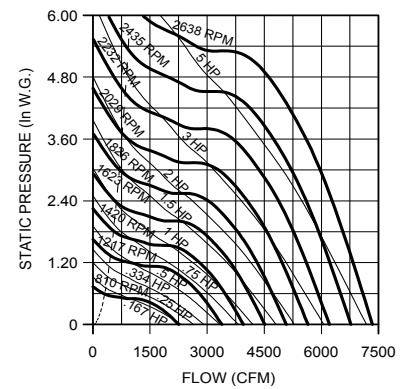
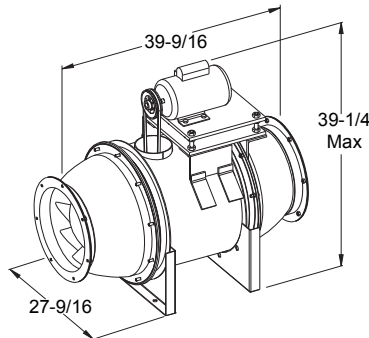

**12 CV-S**

CFM	OV	Static Pressure															
		1/2" SP		3/4" SP		1" SP		2" SP		3" SP		4" SP		5" SP		6" SP	
		RPM	BHP	RPM	BHP	RPM	BHP	RPM	BHP	RPM	BHP	RPM	BHP	RPM	BHP	RPM	BHP
600	780	1188	.13	1423	.20	1610	.29	2180	.70	2621	1.18	2993	1.73	3320	2.34		
725	942	1207	.15	1453	.23	1652	.32	2229	.76	2667	1.28	3038	1.85	3366	2.48		
850	1105	1243	.17	1472	.26	1680	.36	2278	.82	2715	1.38	3084	1.99	3411	2.64		
975	1267	1300	.20	1500	.29	1699	.40	2322	.89	2764	1.46	3132	2.11	3457	2.81		
1100	1430	1372	.23	1546	.33	1725	.44	2356	.96	2811	1.56	3182	2.23	3506	2.96		
1225	1592	1453	.27	1608	.37	1766	.49	2380	1.04	2853	1.66	3230	2.35	3555	3.11		
1350	1755	1540	.32	1682	.42	1823	.54	2398	1.11	2886	1.77	3274	2.48	3604	3.26		
1475	1918	1630	.37	1762	.48	1891	.60	2420	1.19	2910	1.90	3312	2.62				
1600	2080	1722	.44	1848	.55	1967	.67	2452	1.28	2929	2.00	3341	2.78				
1725	2243	1818	.51	1937	.63	2049	.75	2495	1.37	2948	2.11	3364	2.94				
1850	2405	1915	.59	2028	.72	2136	.85	2549	1.48	2973	2.23	3383	3.09				
1975	2568	2015	.68	2121	.82	2225	.95	2613	1.59	3008	2.36	3402	3.23				
2100	2730	2118	.79	2216	.93	2316	1.07	2683	1.71	3051	2.51						
2225	2893	2221	.90	2313	1.05	2408	1.20	2759	1.84	3104	2.66						
2350	3055	2326	1.03	2413	1.18	2502	1.34	2839	2.00	3164	2.82						
2600	3381	2539	1.33	2616	1.49	2695	1.65	3009	2.37	3302	3.18						
2850	3706	2752	1.68	2825	1.85	2896	2.03	3188	2.80								
3100	4031	2973	2.11	3036	2.28	3101	2.47	3371	3.29								
3350	4356	3191	2.60	3252	2.79	3312	2.98										
3600	4681	3408	3.15														

**14 CV-S**

CFM	OV	Static Pressure															
		1/2" SP		3/4" SP		1" SP		2" SP		3" SP		4" SP		5" SP		6" SP	
		RPM	BHP	RPM	BHP	RPM	BHP	RPM	BHP	RPM	BHP	RPM	BHP	RPM	BHP	RPM	BHP
850	795	1022	.18	1226	.29	1388	.40	1877	.97	2256	1.64	2575	2.39	2855	3.22	3108	4.13
1000	935	1037	.20	1248	.32	1419	.44	1915	1.05	2290	1.76	2609	2.54	2890	3.40	3144	4.33
1150	1075	1064	.23	1262	.35	1440	.49	1951	1.12	2326	1.87	2643	2.70	2924	3.59	3178	4.55
1300	1216	1105	.26	1281	.39	1454	.54	1985	1.19	2363	1.97	2679	2.85	2958	3.79	3212	4.79
1450	1356	1158	.30	1313	.43	1472	.58	2013	1.28	2400	2.08	2716	2.99	2995	3.98	3247	5.02
1600	1496	1217	.34	1356	.48	1499	.64	2034	1.38	2433	2.20	2753	3.13	3032	4.16		
1750	1637	1281	.40	1408	.53	1537	.70	2049	1.47	2461	2.33	2788	3.28	3069	4.33		
1900	1777	1348	.46	1466	.60	1584	.76	2063	1.55	2483	2.48	2820	3.45	3104	4.51		
2050	1917	1417	.53	1529	.67	1637	.84	2081	1.65	2500	2.62	2847	3.62	3138	4.71		
2200	2057	1487	.61	1594	.76	1696	.92	2107	1.75	2514	2.75	2868	3.82	3167	4.92		
2350	2198	1559	.70	1662	.86	1758	1.02	2140	1.87	2529	2.87	2885	4.01	3192	5.16		
2500	2338	1633	.79	1731	.97	1823	1.14	2181	2.00	2547	3.01	2899	4.18	3212	5.41		
2650	2478	1708	.90	1800	1.08	1890	1.26	2227	2.12	2572	3.17	2913	4.35				
2800	2619	1785	1.02	1872	1.21	1958	1.40	2279	2.26	2602	3.34	2930	4.53				
2950	2759	1862	1.15	1944	1.34	2027	1.55	2334	2.42	2640	3.53	2951	4.73				
3100	2899	1942	1.30	2018	1.50	2098	1.71	2394	2.60	2682	3.71	2977	4.94				
3400	3180	2101	1.64	2172	1.84	2242	2.06	2519	3.01	2781	4.11	3046	5.42				
3700	3461	2264	2.03	2327	2.25	2392	2.48	2652	3.50	2893	4.59						
4000	3741	2426	2.48	2486	2.72	2546	2.97	2788	4.04	3016	5.17						
4300	4022	2593	3.02	2647	3.26	2702	3.52	2927	4.65								

**16 CV-S**

CFM	OV	Static Pressure															
		1/2" SP		3/4" SP		1" SP		2" SP		3" SP		4" SP		5" SP		6" SP	
		RPM	BHP	RPM	BHP	RPM	BHP	RPM	BHP	RPM	BHP	RPM	BHP	RPM	BHP	RPM	BHP
1100	794	810	.18	990	.29	1129	.41	1559	.99	1888	1.69	2159	2.48	2395	3.34	2605	4.26
1300	938	823	.20	992	.32	1144	.46	1573	1.06	1905	1.79	2183	2.63	2423	3.53	2638	4.50
1500	1083	853	.24	999	.36	1145	.50	1591	1.14	1920	1.90	2200	2.76	2445	3.71		
1700	1227	893	.27	1022	.40	1151	.54	1609	1.23	1935	2.00	2215	2.90	2461	3.87		
1900	1371	938	.31	1057	.45	1171	.60	1619	1.32	1955	2.14	2230	3.04	2476	4.05		
2100	1516	986	.36	1098	.50	1203	.66	1619	1.39	1973	2.28	2248	3.21	2491	4.23		
2300	1660	1039	.41	1142	.56	1241	.73	1622	1.48	1983	2.41	2267	3.38	2509	4.43		
2500	1805	1095	.47	1190	.63	1284	.80	1635	1.58	1984	2.52	2283	3.57	2528	4.65		
2700	1949	1153	.55	1241	.70	1329	.88	1658	1.69	1984	2.64	2290	3.74	2546	4.88		
2900	2093	1214	.63	1296	.79	1377	.97	1689	1.82	1991	2.78	2290	3.89	2557	5.10		
3100	2238	1276	.72	1352	.89	1429	1.08	1725	1.95	2006	2.93	2290	4.05	2561	5.30		
3300	2382	1339	.82	1411	1.00	1483	1.19	1765	2.09	2030	3.11	2296	4.23	2561	5.50		
3500	2527	1403	.93	1471	1.12	1539	1.32	1808	2.24	2060	3.29	2310	4.44				
3700	2671	1468	1.06	1533	1.25	1597	1.46	1853	2.40	2095	3.48	2330	4.66				
3900	2815	1533	1.19	1595	1.40	1656	1.61	1899	2.57	2133	3.68	2356	4.89				
4300	3104	1666	1.50	1723	1.73	1778	1.95	1999	2.96	2217	4.12	2424	5.40				
4700	3393	1801	1.87	1853	2.11	1904	2.36	2106	3.41	2308	4.62						
5100	3682	1936	2.30	1985	2.56	2033	2.82	2219	3.93	2405	5.17						
5500	3971	2074	2.80	2118	3.07	2164	3.36	2337	4.53								
5900	4259	2210	3.35	2254	3.66	2296	3.96	2459	5.20								

Performance certified is for installation type B - Free inlet, Ducted outlet. Power rating (BHP) does not include transmission losses. Performance does not include the effects of appurtenances (accessories).



# 18-24 CV-S Performance Data

## 18 CV-S

**Inlet/Outlet Diameter** - 18"  
**Max. BHP** =  $0.613 \times (\text{RPM}/1000)^3$   
**Outlet Area** - 1.77 FT<sup>2</sup>  
**Outlet Velocity (FPM)** - CFM x 1.77  
**1140 RPM motor required**  
**on 492 and lower FRPM**

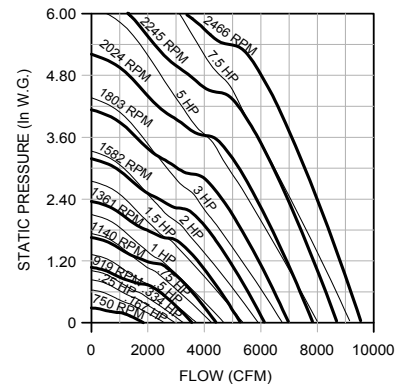
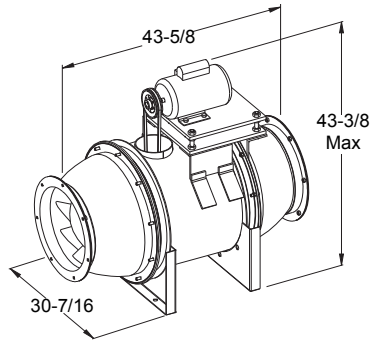

## 20 CV-S

**Inlet/Outlet Diameter** - 20"  
**Max. BHP** =  $0.992 \times (\text{RPM}/1000)^3$   
**Outlet Area** - 2.18 FT<sup>2</sup>  
**Outlet Velocity (FPM)** - CFM x 2.18  
**1140 RPM motor required**  
**on 492 and lower FRPM**

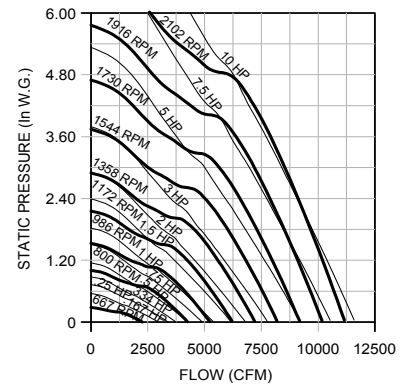
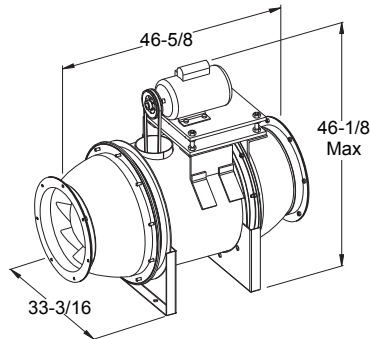

## 24 CV-S

**Inlet/Outlet Diameter** - 24"  
**Max. BHP** =  $2.62 \times (\text{RPM}/1000)^3$   
**Outlet Area** - 3.14 FT<sup>2</sup>  
**Outlet Velocity (FPM)** - CFM x 3.14  
**1140 RPM motor required**  
**on 431 and lower FRPM**

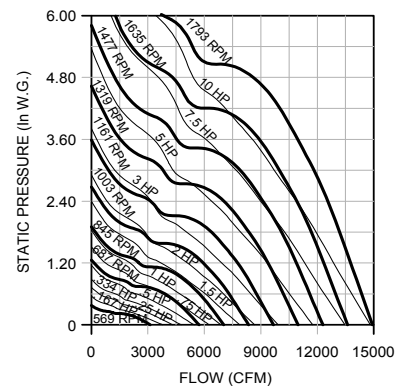
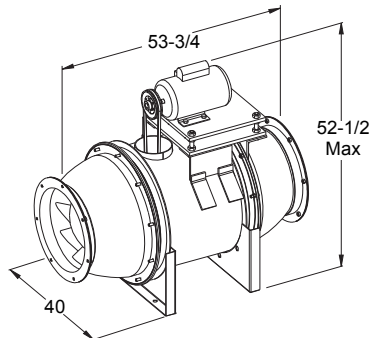

**18 CV-S**

CFM	OV	Static Pressure															
		1/2" SP		3/4" SP		1" SP		2" SP		3" SP		4" SP		5" SP		6" SP	
		RPM	BHP	RPM	BHP	RPM	BHP	RPM	BHP	RPM	BHP	RPM	BHP	RPM	BHP	RPM	BHP
1450	816	750	.25	894	.40	1014	.55	1377	1.28	1647	2.16	1874	3.16	2076	4.29	2260	5.52
1700	957	763	.28	915	.45	1035	.62	1404	1.40	1677	2.31	1904	3.34	2105	4.49	2288	5.75
1950	1098	797	.33	923	.49	1056	.68	1426	1.51	1706	2.47	1935	3.54	2136	4.72	2317	6.00
2200	1239	837	.39	949	.56	1064	.74	1446	1.64	1730	2.64	1964	3.76	2166	4.97	2348	6.29
2450	1380	882	.45	986	.63	1084	.82	1469	1.77	1751	2.83	1990	3.99	2195	5.25	2378	6.60
2700	1521	930	.53	1026	.71	1118	.92	1490	1.91	1771	3.01	2012	4.23	2221	5.53	2407	6.93
2950	1661	979	.61	1071	.81	1157	1.03	1500	2.02	1794	3.22	2031	4.47	2243	5.82	2432	7.26
3200	1802	1031	.71	1118	.92	1199	1.14	1508	2.13	1817	3.42	2052	4.73	2263	6.12	2455	7.61
3450	1943	1083	.81	1167	1.04	1245	1.27	1531	2.30	1833	3.61	2076	5.00	2283	6.44		
3700	2084	1137	.93	1217	1.17	1292	1.41	1564	2.51	1839	3.76	2098	5.27	2306	6.77		
3950	2225	1192	1.07	1269	1.32	1341	1.57	1602	2.72	1849	3.94	2115	5.52	2329	7.11		
4200	2366	1247	1.21	1321	1.47	1391	1.75	1641	2.93	1872	4.20	2122	5.73	2351	7.45		
4450	2507	1304	1.37	1375	1.65	1442	1.94	1683	3.15	1904	4.50	2129	5.95	2366	7.76		
4700	2647	1361	1.55	1429	1.84	1494	2.14	1727	3.40	1941	4.82	2146	6.25	2373	8.01		
4950	2788	1419	1.75	1484	2.05	1547	2.36	1773	3.67	1979	5.13	2174	6.62				
5200	2929	1477	1.96	1540	2.28	1601	2.60	1821	3.96	2019	5.45	2208	7.04				
5700	3211	1595	2.45	1654	2.79	1710	3.14	1919	4.61	2105	6.15	2283	7.88				
6200	3492	1715	3.02	1770	3.39	1822	3.76	2020	5.33	2198	6.98						
6700	3774	1835	3.67	1887	4.07	1937	4.47	2124	6.15	2294	7.89						
7200	4056	1959	4.44	2006	4.85	2053	5.28	2231	7.06								

**20 CV-S**

CFM	OV	Static Pressure															
		1/2" SP		3/4" SP		1" SP		2" SP		3" SP		4" SP		5" SP		6" SP	
		RPM	BHP	RPM	BHP	RPM	BHP	RPM	BHP	RPM	BHP	RPM	BHP	RPM	BHP	RPM	BHP
1600	738	667	.29	793	.45	901	.64	1223	1.51	1465	2.56	1671	3.78				
1925	888	677	.32	814	.52	920	.72	1251	1.65	1495	2.75	1699	4.00	1880	5.40	2044	6.92
2250	1038	700	.38	827	.57	942	.80	1274	1.80	1523	2.95	1728	4.25	1909	5.69	2071	7.23
2575	1188	736	.45	841	.64	955	.88	1293	1.95	1548	3.17	1757	4.53	1938	6.00	2100	7.59
2900	1338	777	.52	873	.74	966	.96	1313	2.12	1569	3.40	1782	4.81	1966	6.35		
3225	1488	821	.61	911	.85	995	1.09	1335	2.30	1588	3.64	1804	5.11	1991	6.70		
3550	1638	868	.72	952	.96	1031	1.23	1349	2.46	1608	3.89	1823	5.43	2014	7.09		
3875	1788	916	.84	996	1.10	1070	1.37	1355	2.59	1631	4.17	1842	5.75	2033	7.47		
4200	1938	966	.98	1042	1.25	1112	1.53	1373	2.80	1648	4.41	1864	6.11	2052	7.88		
4525	2088	1017	1.13	1089	1.42	1157	1.72	1404	3.06	1655	4.62	1886	6.47				
4850	2238	1068	1.30	1138	1.61	1203	1.92	1439	3.33	1663	4.84	1903	6.80				
5175	2388	1121	1.49	1188	1.82	1250	2.15	1476	3.60	1684	5.17	1910	7.07				
5500	2538	1174	1.70	1238	2.04	1299	2.40	1516	3.90	1715	5.57	1916	7.34				
5825	2688	1229	1.94	1290	2.29	1348	2.66	1558	4.22	1749	5.97	1933	7.74				
6150	2838	1284	2.19	1342	2.56	1398	2.95	1602	4.58	1786	6.39	1960	8.24				
6800	3137	1395	2.78	1449	3.19	1501	3.61	1693	5.37	1864	7.24						
7450	3437	1508	3.48	1558	3.92	1607	4.38	1787	6.26								
8100	3737	1622	4.30	1668	4.77	1715	5.27	1885	7.29								
8750	4037	1738	5.26	1781	5.76	1824	6.28										
9400	4337	1854	6.35	1895	6.89	1935	7.44										

**24 CV-S**

CFM	OV	Static Pressure															
		1/2" SP		3/4" SP		1" SP		2" SP		3" SP		4" SP		5" SP		6" SP	
		RPM	BHP	RPM	BHP	RPM	BHP	RPM	BHP	RPM	BHP	RPM	BHP	RPM	BHP	RPM	BHP
2500	804	569	.42	690	.68	786	.96	1043	2.09	1262	3.57	1442	5.28	1599	7.20	1738	9.25
2950	948	587	.48	694	.74	797	1.05	1065	2.31	1274	3.77	1459	5.53	1619	7.49	1762	9.63
3400	1093	615	.56	709	.84	801	1.14	1102	2.62	1291	4.06	1471	5.80	1634	7.79	1780	9.98
3850	1238	649	.65	732	.94	815	1.26	1125	2.87	1323	4.48	1487	6.17	1646	8.15	1793	10.30
4300	1383	686	.76	762	1.06	837	1.40	1127	3.01	1360	4.96	1516	6.70	1663	8.63		
4750	1527	725	.88	798	1.21	865	1.55	1132	3.21	1379	5.30	1555	7.36	1690	9.27		
5200	1672	766	1.02	835	1.38	898	1.73	1144	3.45	1381	5.51	1583	7.90	1729	10.10		
5650	1817	810	1.19	873	1.55	935	1.95	1162	3.70	1384	5.77	1594	8.27	1762	10.80		
6100	1962	856	1.38	914	1.75	972	2.17	1185	3.97	1393	6.11	1594	8.54				
6550	2106	902	1.59	956	1.97	1011	2.41	1212	4.26	1407	6.47	1598	8.91				
7000	2251	950	1.83	1000	2.23	1051	2.67	1243	4.60	1426	6.85	1607	9.35				
7450	2396	999	2.10	1046	2.52	1093	2.96	1278	4.99	1450	7.27	1621	9.85				
7900	2541	1048	2.40	1093	2.84	1137	3.29	1314	5.41	1476	7.70	1639	10.40				
8350	2685	1098	2.73	1140	3.18	1182	3.65	1352	5.86	1507	8.20	1660	10.90				
8800	2830	1148	3.09	1189	3.57	1228	4.05	1390	6.32	1540	8.75						
9700	3119	1249	3.90	1287	4.44	1323	4.97	1469	7.32	1611	9.96						
10600	3409	1350	4.85	1386	5.45	1420	6.03	1552	8.47								
11500	3698	1454	5.99	1486	6.61	1519	7.26	1640	9.81								
12400	3988	1556	7.25	1588	7.96	1618	8.65										
13300	4277	1661	8.75	1690	9.48	1718	10.20										

Performance certified is for installation type B - Free inlet, Ducted outlet. Power rating (BHP) does not include transmission losses. Performance does not include the effects of appurtenances (accessories).

## 28 CV-S

**Inlet/Outlet Diameter** - 28"  
**Max. BHP** =  $5.69 \times (\text{RPM}/1000)^3$   
**Outlet Area** - 4.28 FT<sup>2</sup>  
**Outlet Velocity (FPM)** - CFM x 4.28  
**1140 RPM motor required**  
**on 421 and lower FRPM**

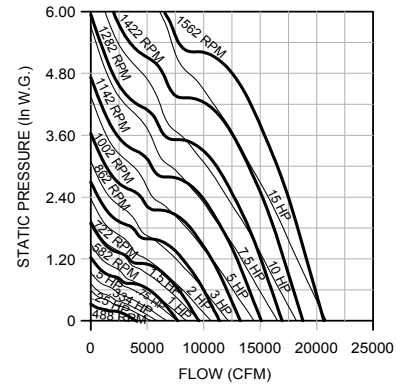
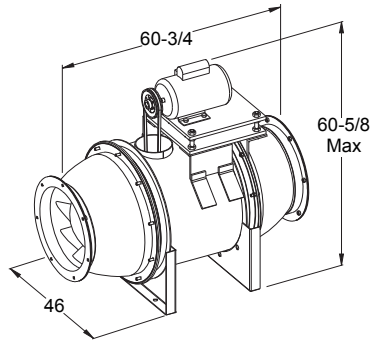

## 32 CV-S

**Inlet/Outlet Diameter** - 32"  
**Max. BHP** =  $10.52 \times (\text{RPM}/1000)^3$   
**Outlet Area** - 5.59 FT<sup>2</sup>  
**Outlet Velocity (FPM)** - CFM x 5.59  
**1140 RPM motor required**  
**on 402 and lower FRPM**

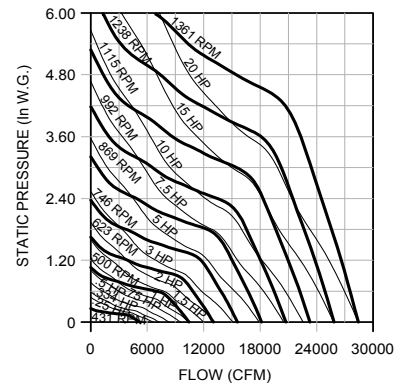
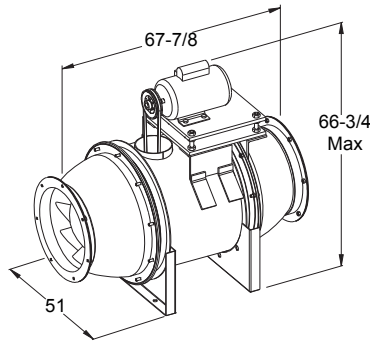

## 36 CV-S

**Inlet/Outlet Diameter** - 36"  
**Max. BHP** =  $19.11 \times (\text{RPM}/1000)^3$   
**Outlet Area** - 7.07 FT<sup>2</sup>  
**Outlet Velocity (FPM)** - CFM x 7.07  
**1140 RPM motor required**  
**on 402 and lower FRPM**

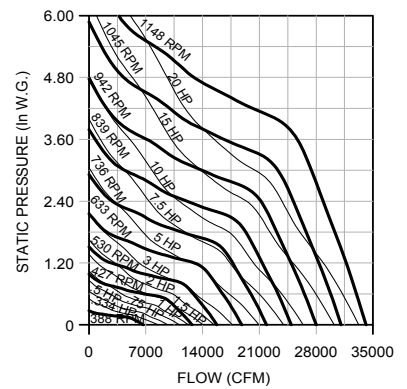
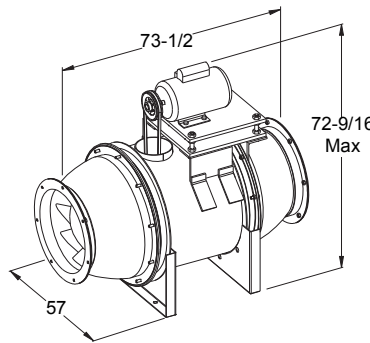

**28 CV-S**

CFM	OV	Static Pressure															
		1/2" SP		3/4" SP		1" SP		2" SP		3" SP		4" SP		5" SP		6" SP	
		RPM	BHP	RPM	BHP	RPM	BHP	RPM	BHP	RPM	BHP	RPM	BHP	RPM	BHP	RPM	BHP
3400	802	488	.57	592	.92	674	1.31	894	2.83	1082	4.85	1237	7.20	1371	9.79	1491	12.60
4025	949	504	.66	595	1.01	684	1.44	913	3.14	1093	5.14	1251	7.52	1389	10.20	1511	13.10
4650	1097	528	.76	608	1.14	687	1.56	947	3.60	1108	5.55	1262	7.91	1402	10.60	1527	13.60
5275	1244	558	.90	629	1.28	700	1.73	965	3.92	1136	6.13	1276	8.43	1412	11.10	1538	14.10
5900	1392	591	1.05	656	1.46	719	1.91	967	4.12	1168	6.79	1302	9.18	1427	11.80	1549	14.80
6525	1539	625	1.22	687	1.67	744	2.13	971	4.39	1183	7.25	1336	10.10	1452	12.70		
7150	1687	661	1.41	720	1.90	774	2.40	982	4.72	1184	7.53	1360	10.80	1486	13.80		
7775	1834	700	1.65	754	2.15	806	2.69	999	5.09	1187	7.90	1367	11.30	1514	14.90		
8400	1982	740	1.92	789	2.43	839	3.00	1019	5.45	1196	8.39	1368	11.70	1527	15.60		
9025	2129	781	2.22	826	2.74	873	3.34	1044	5.88	1209	8.90	1371	12.20	1529	16.10		
9650	2277	823	2.56	865	3.10	908	3.71	1072	6.37	1227	9.45	1380	12.90				
10275	2424	866	2.95	905	3.51	945	4.12	1102	6.91	1248	10.00	1393	13.50				
10900	2572	909	3.37	946	3.96	984	4.59	1134	7.50	1272	10.60	1409	14.20				
11525	2719	952	3.83	988	4.46	1024	5.11	1167	8.12	1299	11.30	1429	15.00				
12150	2867	996	4.34	1031	5.01	1064	5.67	1201	8.78	1329	12.10	1452	15.80				
13400	3162	1084	5.49	1117	6.25	1147	6.97	1270	10.20	1392	13.90						
14650	3457	1173	6.85	1204	7.69	1232	8.47	1344	11.80	1458	15.70						
15900	3752	1264	8.47	1291	9.33	1319	10.20	1422	13.80								
17150	4047	1354	10.30	1381	11.30	1406	12.20	1503	16.00								
18400	4342	1446	12.40	1470	13.40	1494	14.50										

**32 CV-S**

CFM	OV	Static Pressure															
		1/2" SP		3/4" SP		1" SP		2" SP		3" SP		4" SP		5" SP		6" SP	
		RPM	BHP	RPM	BHP	RPM	BHP	RPM	BHP	RPM	BHP	RPM	BHP	RPM	BHP	RPM	BHP
4400	793	431	.80	516	1.29	585	1.79										
5200	938	442	.90	526	1.43	597	2.01	807	4.42								
6000	1082	451	1.01	537	1.59	607	2.20	823	4.93								
6800	1226	463	1.10	546	1.74	618	2.41	837	5.40	997	8.54						
7600	1371	483	1.24	556	1.90	628	2.62	848	5.81	1012	9.27	1146	12.80				
8400	1515	510	1.45	568	2.03	637	2.83	858	6.20	1026	9.97	1162	13.80	1280	17.80		
9200	1660	541	1.70	588	2.24	647	3.01	868	6.59	1037	10.60	1177	14.80	1295	19.00		
10000	1804	573	1.99	615	2.54	662	3.21	879	7.01	1047	11.20	1189	15.70	1310	20.20		
10800	1948	606	2.31	644	2.89	684	3.52	889	7.44	1057	11.80	1200	16.50	1324	21.40		
11600	2093	638	2.63	676	3.31	712	3.94	898	7.86	1068	12.40	1210	17.30				
12400	2237	671	2.98	708	3.74	741	4.41	907	8.24	1078	13.00	1220	18.10				
13200	2381	705	3.38	741	4.22	773	4.96	918	8.59	1088	13.60	1231	18.90				
14000	2526	739	3.81	773	4.70	805	5.53	933	9.00	1097	14.30	1241	19.70				
14800	2670	774	4.30	806	5.22	837	6.13	953	9.55	1106	14.90	1251	20.50				
15600	2814	809	4.84	840	5.79	870	6.78	978	10.30	1116	15.40	1261	21.40				
17200	3103	880	6.08	907	7.04	936	8.15	1036	12.10	1144	16.60						
18800	3392	951	7.54	977	8.56	1003	9.71	1098	14.20	1188	18.40						
20400	3680	1025	9.31	1047	10.30	1071	11.50	1163	16.60	1244	21.00						
22000	3969	1097	11.30	1119	12.40	1141	13.60	1228	19.10								
23600	4258	1172	13.60	1191	14.70	1211	16.00	1293	21.70								

**36 CV-S**

CFM	OV	Static Pressure															
		1/2" SP		3/4" SP		1" SP		2" SP		3" SP		4" SP		5" SP		6" SP	
		RPM	BHP	RPM	BHP	RPM	BHP	RPM	BHP	RPM	BHP	RPM	BHP	RPM	BHP	RPM	BHP
6000	848	388	1.07	462	1.70	525	2.39										
7050	997	397	1.21	472	1.90	535	2.66	724	5.90								
8100	1145	405	1.33	482	2.11	545	2.93	738	6.54	879	10.30						
9150	1294	420	1.48	490	2.31	554	3.19	749	7.11	894	11.30	1012	15.60				
10200	1442	443	1.71	499	2.49	563	3.47	759	7.64	907	12.30	1027	17.00	1132	21.90		
11250	1591	470	2.02	515	2.72	572	3.73	768	8.15	918	13.10	1041	18.30				
12300	1739	499	2.38	537	3.06	583	3.96	778	8.69	928	13.90	1053	19.40				
13350	1888	529	2.78	564	3.51	601	4.31	787	9.23	937	14.70	1063	20.50				
14400	2037	559	3.21	593	4.04	625	4.81	796	9.81	947	15.50	1073	21.60				
15450	2185	590	3.67	622	4.59	653	5.45	804	10.30	956	16.20						
16500	2334	621	4.18	652	5.20	681	6.12	814	10.80	966	17.10						
17550	2482	652	4.73	683	5.86	711	6.89	827	11.30	974	17.90						
18600	2631	684	5.36	713	6.53	741	7.68	845	12.00	982	18.70						
19650	2779	716	6.06	744	7.26	770	8.48	867	12.90	991	19.40						
20700	2928	748	6.81	775	8.06	801	9.38	893	14.00	1002	20.10						
22800	3225	815	8.63	838	9.86	862	11.30	949	16.60								
24900	3522	881	10.70	903	12.00	924	13.50	1007	19.50								
27000	3819	949	13.20	968	14.60	988	16.00										
29100	4116	1017	16.10	1034	17.50	1053	19.00										
31200	4413	1085	19.40	1102	20.90												

Performance certified is for installation type B - Free inlet, Ducted outlet. Power rating (BHP) does not include transmission losses. Performance does not include the effects of appurtenances (accessories).

## 8 CVD

RPM	SP	Sound Power re 10-12 Watts								Sones
		Octave Bands								
		1	2	3	4	5	6	7	8	
1550	0.13	58	59	64	61	55	52	47	44	5.4
	0.25	59	60	63	61	54	51	46	42	5.1
	0.38	60	60	62	59	53	49	44	38	4.7
	0.50	62	59	60	58	51	48	43	34	4.2

## 10 CVD

RPM	SP	Sound Power re 10-12 Watts								Sones
		Octave Bands								
		1	2	3	4	5	6	7	8	
1140	0.13	58	61	63	58	54	50	46	42	4.9
	0.25	59	60	63	57	52	48	43	39	4.5
	0.38	60	59	60	55	50	47	41	33	3.8
	0.50	61	58	58	53	48	46	38	23	3.2
1725	0.13	70	70	74	73	65	62	57	54	10.4
	0.25	70	70	74	73	65	62	57	54	10.3
	0.38	70	70	74	72	65	61	56	52	10.1
	0.50	71	71	73	72	64	61	55	51	9.9
	0.63	71	71	73	72	63	60	55	50	9.6
	0.75	72	71	72	71	62	59	54	48	9.1
	0.88	73	71	71	70	61	58	54	46	8.7
	1.00	75	71	70	69	60	57	54	45	8.3

## 12 CVD

RPM	SP	Sound Power re 10-12 Watts								Sones
		Octave Bands								
		1	2	3	4	5	6	7	8	
1140	0.13	65	68	70	65	60	56	52	48	7.3
	0.25	65	67	69	64	59	55	50	46	7.1
	0.38	66	67	69	63	58	53	49	44	6.7
	0.50	66	66	67	61	56	53	47	40	6.1
	0.63	67	65	66	60	55	52	45	35	5.6
1725	0.75	68	64	64	58	53	51	43	25	5.0
	0.25	77	77	81	79	71	68	63	59	15.0
	0.38	77	77	80	79	71	68	63	59	15.0
	0.50	77	77	80	78	71	67	62	58	14.7
	0.63	77	77	80	78	70	67	61	57	14.5
	0.75	78	77	80	78	70	66	61	57	14.3
	0.88	78	78	79	78	69	65	60	56	14.0
	1.00	79	78	79	77	69	65	60	54	13.5
	1.25	80	78	77	76	67	64	60	52	12.7
	1.50	82	78	76	74	66	63	59	49	12.0
1.75	83	78	74	73	64	61	59	46	11.3	

## 14 CVD

RPM	SP	Sound Power re 10-12 Watts								Sones
		Octave Bands								
		1	2	3	4	5	6	7	8	
1140	0.13	60	71	72	69	69	67	67	68	14.1
	0.25	62	72	72	68	68	67	67	68	13.9
	0.38	64	71	71	68	67	66	66	67	13.1
	0.50	66	71	70	68	67	65	65	66	12.4
	0.63	68	71	70	67	65	62	61	62	10.9
	0.75	71	72	70	67	64	60	58	58	9.4
	0.88	73	73	70	66	62	57	54	52	8.4
	1725	0.13	65	76	84	79	79	79	76	77
0.25		65	76	85	78	78	78	76	77	24
0.38		66	77	86	78	78	77	76	77	24
0.50		66	78	87	78	78	77	76	77	24
0.63		67	79	86	78	77	76	75	76	24
0.75		67	80	85	78	77	76	75	76	23
0.88		68	81	84	78	77	76	74	75	23
1.00		69	82	82	78	77	75	74	75	22
1.25		70	84	81	78	77	74	72	73	21
1.50		73	86	81	78	76	73	69	70	19.2
1.75	76	87	81	78	75	71	67	66	18.4	
2.00	79	89	82	77	74	69	64	63	18.4	

## 16 CVD

RPM	SP	Sound Power re 10-12 Watts								Sones
		Octave Bands								
		1	2	3	4	5	6	7	8	
1140	0.13	71	76	76	76	76	71	68	64	17.4
	0.25	72	76	76	75	80	71	68	63	17.2
	0.38	72	76	77	75	79	71	67	63	17.0
	0.50	74	77	77	75	77	69	65	60	15.6
	0.63	75	77	78	74	75	66	62	57	14.2
	0.75	77	78	78	74	73	64	59	54	13.0
	0.88	79	78	78	73	70	61	56	51	12.4
	1.00	80	79	78	73	68	59	54	48	12.0
	1.25	83	80	79	72	63	54	48	42	11.5
	1725	0.13	78	85	85	86	87	86	79	75
0.25		78	85	85	86	87	86	79	75	31
0.38		79	85	85	86	87	85	79	75	31
0.50		79	85	85	86	87	85	79	75	31
0.63		79	85	86	86	86	85	79	75	31
0.75		79	85	86	86	86	85	79	75	31
0.88		80	86	86	86	86	85	78	74	31
1.00		80	86	86	86	86	84	77	73	30
1.25		82	87	87	86	85	82	75	71	28
1.50		83	88	87	86	84	80	73	68	26
1.75		85	89	87	86	83	78	71	66	25
2.00		86	90	88	86	82	76	68	63	25
2.50		89	92	88	86	79	72	64	58	24
3.00		92	94	89	86	77	68	59	53	24

## 18 CVD

RPM	SP	Sound Power re 10-12 Watts								Sones
		Octave Bands								
		1	2	3	4	5	6	7	8	
1140	0.13	74	76	78	81	84	78	73	69	22
	0.25	77	76	77	81	83	78	73	69	22
	0.38	79	76	77	81	83	77	73	69	22
	0.50	81	75	76	81	83	77	73	68	22
	0.63	80	75	76	81	83	77	73	68	22
	0.75	80	75	76	80	83	77	73	68	21
	0.88	80	76	77	80	82	77	73	68	21
	1.00	80	76	77	80	82	76	73	67	21
	1.25	83	78	78	80	81	75	70	66	20
	1.50	86	80	80	80	80	74	68	65	19.6
1.75	88	81	81	80	79	72	65	63	19.2	

## 20 CVD

RPM	SP	Sound Power re 10-12 Watts								Sones
		Octave Bands								
		1	2	3	4	5	6	7	8	
1140	0.13	75	69	77	83	85	81	76	71	24
	0.25	75	69	77	83	85	80	76	71	24
	0.38	76	70	77	83	85	80	76	71	24
	0.50	76	70	77	83	85	80	76	71	24
	0.63	78	72	78	82	84	79	75	70	23
	0.75	80	74	79	82	84	79	75	70	23
	0.88	82	75	80	82	83	78	74	69	23
	1.00	84	77	80	81	83	78	74	69	23
	1.25	88	80	82	81	82	76	72	67	22
	1.50	92	82	82	80	80	74	69	64	21
	1.75	95	83	82	79	78	71	66	60	21

The sound power level ratings shown are in decibels, referred to 10<sup>-12</sup> watts calculated per AMCA Standard 301. Values shown are for Lwi sound power levels for installation type B - Free inlet, Ducted outlet. Ratings do not include the effects of duct end correction. The sound ratings shown are loudness values in fan sones at 5 ft. (1.5m) in a hemispherical free field calculated per AMCA Standard 301. Values shown are for installation type B - free inlet hemispherical sone levels.



12 CVB

RPM	SP	Sound Power re 10-12 Watts								Sones
		Octave Bands								
		1	2	3	4	5	6	7	8	
1000	0.250	57	60	63	64	61	55	49	43	6.1
1200	0.250	60	66	66	68	67	61	55	49	8.4
1300	0.250	64	67	68	70	69	63	57	51	9.6
1500	0.250	70	69	70	73	73	68	62	56	12.2
	0.500	69	70	71	73	72	68	62	56	12.1
	0.750	68	70	72	74	72	68	62	56	12.1
1800	0.250	77	73	74	77	77	74	67	61	16.4
	0.500	78	74	75	77	77	73	67	61	16.3
	0.750	76	74	76	77	77	73	67	61	16.3
2100	1.000	74	74	76	78	77	73	67	61	16.2
	0.250	84	78	77	80	81	79	72	66	21
	0.500	84	77	79	80	81	78	72	66	21
2400	1.000	82	78	80	81	81	78	72	66	21
	1.500	77	78	79	82	81	78	72	66	21
	0.250	89	82	80	82	84	83	76	70	27
2700	0.500	89	81	81	83	84	83	76	70	27
	1.000	90	80	84	83	84	82	76	70	27
	2.000	80	82	82	85	84	82	76	70	26
3000	3.000	70	84	80	87	84	82	76	70	26
	0.250	91	87	83	84	86	86	80	74	32
	0.500	91	86	84	85	86	86	80	74	32
3300	1.000	92	85	85	85	86	85	80	74	32
	2.000	86	85	86	86	87	85	80	74	31
	3.000	78	85	85	88	87	85	80	74	31
1000	0.250	93	91	87	86	88	88	83	77	38
	0.500	93	90	87	86	88	88	83	77	38
	1.000	93	90	87	87	89	88	83	77	38
1200	2.000	91	89	88	87	89	88	83	77	37
	4.000	78	87	88	90	90	88	83	77	37
	0.250	95	94	89	88	90	90	86	80	45
1500	0.500	95	94	89	88	90	90	86	80	45
	1.000	95	94	90	89	91	90	86	80	45
	2.000	95	94	91	90	91	90	86	80	44
1800	4.000	84	90	90	91	92	90	86	80	43

14 CVB

RPM	SP	Sound Power re 10-12 Watts								Sones
		Octave Bands								
		1	2	3	4	5	6	7	8	
900	0.250	63	68	66	66	64	58	53	47	7.5
1200	0.250	73	75	76	73	73	69	64	59	13.6
	0.500	72	74	76	73	71	66	60	54	11.9
1500	0.250	77	80	83	78	79	77	70	66	19.9
	0.500	79	81	83	78	78	76	69	64	19.4
	0.750	80	78	84	78	77	73	67	61	17.9
1800	0.250	80	83	86	83	83	82	76	71	27
	0.500	82	85	87	83	83	82	76	71	26
	0.750	83	85	87	83	83	81	75	69	26
	1.000	84	83	87	83	82	79	73	68	24
2100	0.250	83	87	90	88	87	86	81	76	34
	0.500	84	88	90	88	86	86	81	75	34
	0.750	85	89	91	88	86	85	80	75	34
	1.000	86	89	91	89	86	85	80	74	33
2400	1.500	87	88	90	89	85	82	77	71	30
	0.250	85	90	92	92	89	89	85	80	42
	0.500	86	91	93	93	89	89	85	79	42
	0.750	86	92	93	93	89	89	85	79	42
	1.000	87	92	94	93	89	89	84	79	42
2700	1.500	88	93	93	93	89	87	83	77	40
	2.000	89	92	92	93	88	86	81	75	38
	1.000	88	95	96	97	92	92	88	82	51
	1.500	90	96	97	97	92	91	88	82	51
3000	2.000	91	96	96	97	91	90	86	80	49
	3.000	92	96	93	97	91	88	84	78	47

16 CVB

RPM	SP	Sound Power re 10-12 Watts								Sones
		Octave Bands								
		1	2	3	4	5	6	7	8	
850	0.250	68	72	69	70	67	61	56	51	9.3
1100	0.250	75	78	77	76	75	71	65	60	15.4
	0.500	75	77	78	75	73	68	62	57	13.8
1350	0.250	79	82	84	80	81	78	71	67	22
	0.500	81	83	84	80	80	77	71	66	21
	0.750	81	81	85	80	78	75	69	63	19.5
1600	1.000	81	79	85	79	77	72	67	60	18.4
	0.250	83	85	88	84	85	83	76	72	29
	0.500	85	87	89	84	85	83	76	71	28
	0.750	86	87	89	84	84	82	75	70	28
1850	1.000	87	85	89	84	83	80	74	68	26
	0.250	86	88	91	88	88	87	81	76	36
	0.500	87	90	92	88	88	87	81	76	36
	0.750	88	91	92	88	88	86	80	75	36
	1.000	88	91	92	89	87	86	80	74	35
2100	1.500	90	88	92	89	86	83	78	72	32
	0.250	88	92	94	92	91	90	85	80	45
	0.500	88	92	94	92	91	90	85	80	44
	0.750	89	93	95	93	91	90	85	79	44
	1.000	90	94	95	93	90	89	84	79	44
	1.500	91	94	95	93	90	88	83	77	42
2350	2.000	92	93	94	93	89	86	81	75	39
	0.250	89	94	96	96	93	93	89	83	54
	0.500	90	95	97	96	93	93	88	83	54
	0.750	91	96	97	96	93	93	88	83	54
	1.000	91	96	98	96	93	92	88	82	54
	1.500	92	97	98	97	93	92	88	82	53
3000	2.000	93	97	97	97	92	91	86	80	50
	3.000	95	96	95	97	91	88	83	77	47

18 CVB

RPM	SP	Sound Power re 10-12 Watts								Sones
		Octave Bands								
		1	2	3	4	5	6	7	8	
750	0.250	69	74	70	70	67	61	56	50	9.5
950	0.250	76	79	77	77	75	70	65	60	15.3
	0.500	74	79	77	75	72	67	61	55	13.3
1150	0.250	80	83	83	81	80	76	70	66	21
	0.500	81	83	83	80	79	75	69	64	20
	0.750	80	82	83	80	77	73	67	61	18.2
1350	0.250	83	86	88	84	84	81	75	71	27
	0.500	85	87	88	84	84	81	75	70	27
	0.750	86	87	88	84	83	80	73	68	26
	1.000	86	85	89	83	82	78	72	66	24
1550	0.250	87	88	92	87	88	86	79	75	34
	0.500	88	90	92	87	88	85	79	74	34
	0.750	89	91	92	87	87	85	78	74	34
	1.000	90	90	93	87	87	84	77	72	32
	1.500	91	86	93	87	85	81	75	69	30
1750	0.250	89	91	94	90	91	89	83	78	42
	0.500	90	92	94	90	91	89	83	78	42
	0.750	91	93	95	90	90	89	82	77	41
	1.000	92	94	95	90	90	88	82	77	41
	1.500	93	92	95	90	89	86	80	75	38
	2.000	94	89	95	90	88	84	79	72	36
1950	0.250	91	94	96	94	93	92	86	81	50
	0.500	91	95	97	94	93	92	86	81	50
	0.750	92	95	97	94	93	91	86	81	50
	1.000	93	96	97	94	93	91	86	80	50
	1.500	94	96	98	94	92	90	85	79	48
2.000	95	95	97	94	91	89	83	77	45	

The sound power level ratings shown are in decibels, referred to 10<sup>-12</sup> watts calculated per AMCA Standard 301. Values shown are for Lwi sound power levels for installation type B - Free inlet, Ducted outlet. Ratings do not include the effects of duct end correction. The sound ratings shown are loudness values in fan sones at 5 ft. (1.5m) in a hemispherical free field calculated per AMCA Standard 301. Values shown are for installation type B - free inlet hemispherical sone levels.

**20 CVB**

RPM	SP	Sound Power re 10-12 Watts								Sones
		Octave Bands								
		1	2	3	4	5	6	7	8	
550	0.250	65	65	67	69	66	60	54	47	8.4
	0.250	78	75	77	80	81	75	70	64	19.7
	0.500	79	77	77	79	81	75	70	63	19.6
	0.750	82	78	78	79	80	74	68	62	18.9
	1.000	84	79	78	79	79	71	65	59	17.8
1250	0.250	83	86	85	86	88	86	79	74	32
	0.500	83	87	85	86	88	86	79	74	33
	0.750	84	87	85	86	88	86	79	74	33
	1.000	85	88	86	86	88	86	79	74	33
	1.500	88	90	87	86	87	85	77	72	31
1600	0.250	87	94	89	90	93	94	86	81	51
	0.500	87	95	89	90	93	94	86	82	51
	0.750	88	95	89	90	93	94	87	82	51
	1.000	88	95	89	90	93	94	87	82	52
	1.500	89	96	90	90	93	94	86	81	52
1950	0.250	90	98	96	95	96	98	93	87	69
	0.500	90	98	96	95	96	98	93	87	70
	1.000	91	98	96	95	96	98	93	87	70
	1.500	91	99	96	95	96	98	93	87	71
	2.000	92	100	97	95	96	98	93	87	71
4.000	0.250	94	101	92	91	92	92	83	77	48
	0.500	90	98	96	95	96	98	93	87	69
	0.500	90	98	96	95	96	98	93	87	70
	1.000	91	98	96	95	96	98	93	87	70
	1.500	91	99	96	95	96	98	93	87	71
3.000	0.250	92	100	97	95	96	98	93	87	71
	0.500	94	101	98	96	96	98	93	87	70
	0.500	96	103	99	97	96	97	91	84	68

**24 CVB**

RPM	SP	Sound Power re 10-12 Watts								Sones
		Octave Bands								
		1	2	3	4	5	6	7	8	
475	0.250	74	70	67	65	62	62	61	58	9.5
	0.250	86	84	80	78	75	74	76	74	22
	0.500	89	83	79	77	75	73	75	73	22
	0.750	92	82	79	77	73	69	68	65	18.5
	1.000	94	81	79	77	73	68	63	59	18.2
750	0.250	90	93	90	86	84	82	82	82	37
	0.500	92	94	90	85	83	81	81	82	36
	0.750	93	95	90	85	83	81	81	81	36
	1.000	95	96	90	85	83	80	80	80	36
	1.500	98	97	89	85	81	77	74	71	31
1025	0.250	100	97	88	85	81	77	72	67	31
	0.250	93	100	98	91	90	87	86	88	55
	0.500	94	101	98	91	89	87	86	88	54
	0.750	95	102	98	91	89	87	86	88	54
	1.000	97	103	98	91	89	87	85	87	54
1300	1.500	99	105	97	91	89	86	85	87	54
	2.000	101	107	97	91	88	85	82	83	55
	3.000	104	109	95	91	88	84	78	74	56
	0.250	96	103	103	97	94	92	91	92	74
	0.500	97	104	103	97	94	92	91	92	73
1575	1.000	98	105	103	97	94	92	90	92	73
	1.500	100	107	103	97	94	92	90	91	72
	2.000	101	108	103	97	94	91	89	91	72
	3.000	104	111	102	97	93	90	87	86	75
	4.000	106	113	101	97	93	89	84	80	78

**28 CVB**

RPM	SP	Sound Power re 10-12 Watts								Sones
		Octave Bands								
		1	2	3	4	5	6	7	8	
400	0.25	71	74	68	66	63	63	60	57	9.5
	0.25	74	83	77	76	70	72	70	67	16.6
	0.50	77	85	77	75	69	71	68	65	16.2
550	0.75	80	84	76	74	68	64	59	54	13.8
	0.25	78	85	86	81	77	76	76	73	23
	0.50	79	86	86	81	77	76	76	73	23
	0.75	80	87	86	81	77	75	75	72	23
	1.00	82	89	86	80	76	73	71	68	21
700	0.25	81	87	92	86	83	80	81	78	31
	0.50	81	88	93	86	83	80	81	78	31
	0.75	82	89	93	86	83	80	81	78	31
	1.00	83	90	93	86	83	79	80	77	31
	1.50	86	92	93	85	82	77	76	72	30
850	0.25	83	90	98	90	88	83	85	82	41
	0.50	84	90	98	90	88	83	85	82	42
	1.00	85	91	99	90	88	83	85	82	42
	1.50	87	93	99	89	88	82	84	81	43
	2.00	88	95	99	89	87	81	81	78	41
1000	0.25	86	92	100	94	91	87	88	85	50
	0.50	86	93	100	94	91	87	88	86	50
	0.75	86	93	101	94	92	87	88	86	51
	1.00	87	93	101	95	92	86	88	86	51
	1.50	88	94	101	95	92	86	87	85	52
1150	2.00	89	96	102	94	91	86	87	85	52
	3.00	92	98	102	94	91	85	82	78	50
	4.00	94	101	105	98	94	88	84	80	61

**32 CVB**

RPM	SP	Sound Power re 10-12 Watts								Sones
		Octave Bands								
		1	2	3	4	5	6	7	8	
350	0.250	71	72	72	66	60	55	50	46	8.0
	0.250	76	78	78	76	70	64	60	55	13.1
	0.500	75	77	76	72	65	59	55	51	10.8
450	0.250	79	83	83	82	76	71	66	62	18.9
	0.500	81	84	83	81	75	69	65	60	18.1
	0.750	80	83	81	79	72	65	61	56	15.3
550	0.250	82	87	86	88	82	76	71	67	25
	0.500	83	88	86	87	81	75	70	66	24
	0.750	85	88	86	86	80	74	69	65	24
	1.000	84	87	85	84	78	70	66	62	21
	1.500	85	89	90	91	86	81	76	71	31
650	0.500	86	90	90	90	86	80	75	70	30
	0.750	87	90	90	90	85	79	74	69	30
	1.000	88	91	90	90	84	78	73	69	29
	1.500	88	89	88	86	81	73	68	64	24
	2.000	89	92	93	93	90	84	79	74	37
750	0.500	89	92	93	93	89	83	78	74	37
	0.750	89	92	93	93	89	83	78	74	37
	1.000	90	93	93	93	89	83	77	73	36
	1.500	92	93	93	92	87	81	75	71	34
	2.000	92	92	91	89	84	77	71	67	29
850	0.500	91	94	96	95	93	88	82	78	46
	0.750	92	94	96	95	93	87	82	77	45
	1.000	92	95	96	95	93	87	81	77	44
	1.500	94	96	97	95	92	86	80	75	43
	2.000	95	96	96	94	90	83	78	73	40

**36 CVB**

RPM	SP	Sound Power re 10-12 Watts								Sones
		Octave Bands								
		1	2	3	4	5	6	7	8	
350	0.250	75	76	76	71	65	60	55	51	10.7
	0.250	78	81	81	78	72	66	62	57	15.0
	0.500	79	80	79	75	68	63	59	54	13.4
425	0.250	81	85	84	83	77	72	67	63	20
	0.500	83	85	84	82	76	70	66	61	19.3
	0.750	82	84	83	80	73	67	62	58	16.7
500	0.250	83	88	87	88	82	76	72	67	26
	0.500	85	89	87	87	81	75	70	66	25
	0.750	86	89	87	86	80	74	69	65	24
575	1.000	85	88	86	84	77	70	66	62	21
	0.250	85	91	90	91	86	80	75	71	32
	0.500	87	91	90	91	85	79	74	70	31
	0.750	88	92	90	90	84	78	73	69	30
	1.000	89	92	90	90	83	77			

# LORENIZED Fan Finish

All steel fan and blower components receive **COOK's LORENIZED** coating as the factory standard, for durable protection and lasting beauty. When this coating goes on, it stays on. It's the industry's most durable standard coating. It comes out sleek and smooth and it stays that way. **COOK's LORENIZED** coating withstands the elements and provides durable protection and lasting beauty.

## The COOK Powder Coating Process

The entire procedure occurs within an environmentally friendly, self-contained, automated system. Water used in the pretreatment recirculates and is neutralized before its release from the system. Excess powder is captured and recycled. No solvents are utilized so there are no polluting fumes or paint vapors to escape. There is virtually nothing in the entire process to adversely effect our environment.

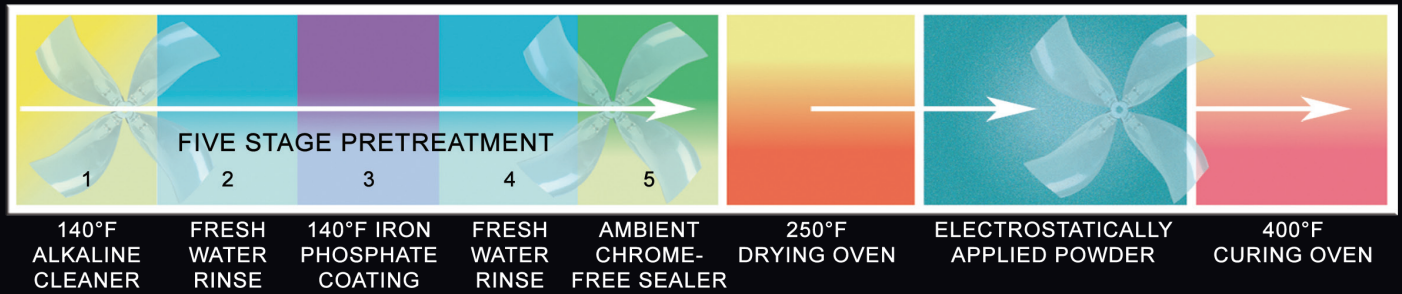

Steel components go through a five stage pretreatment process before the powder is applied. They are washed and treated until all surfaces are perfectly clean, chemically prepared and electrostatically charged - ready to bond with the powder. This ensures excellent coating adhesion, uniformity and consistent edge coverage. Then, a worker or an automated system of sprayers applies the powder that chemically bonds to the prepared surface. Components are then cured in a 400°F oven. This process creates adhesion, durability and a smoothness of coating not possible with conventional liquid paints.



Pretreatment system

### Other Available Coatings

Where particularly harsh environmental conditions require exceptional chemical resistance, these optional coatings may apply:

- Cook Epoxy Powder
- Cook Phenolic Epoxy Powder
- Cook Easy Clean Powder
- Cook High Temp
- Air Dry Phenolic (Heresite® VR-504)

Any color is available.



Powder application



## **LOREN COOK COMPANY**

2015 E. DALE STREET  
SPRINGFIELD, MO 65803-4637

417.869.6474

FAX 417.862.3820

[lorencook.com](http://lorencook.com)