

# DOMEX

Centrifugal Roof Exhausters

## TECHNICAL SPECIFICATIONS

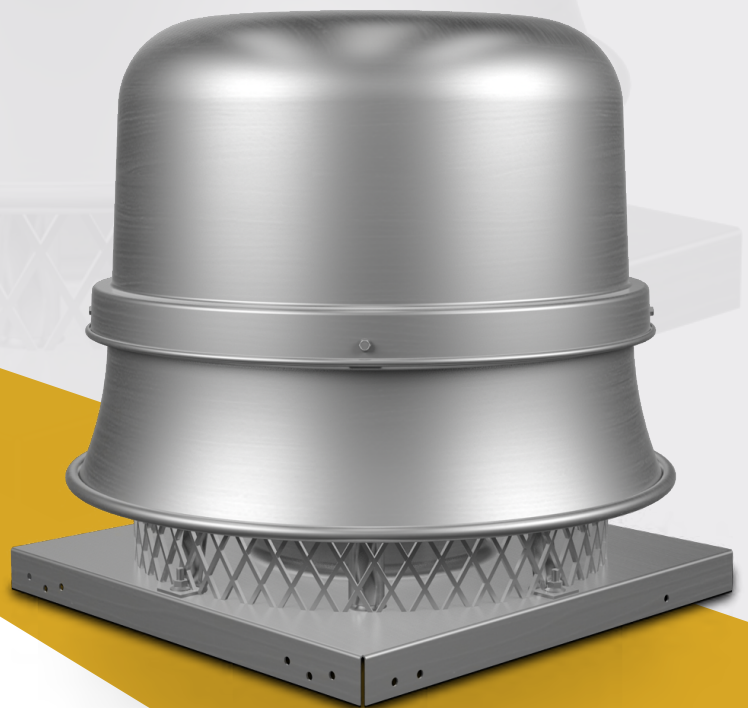

PENNBARRY™

BULLETIN DX18

# TABLE OF CONTENTS

INTRODUCTION	3
CERTIFICATIONS & LISTINGS	4
DX06, DX08, DX10, & DX11   DIRECT DRIVE	5
DX13   DIRECT DRIVE	6
DX16 & DX18   DIRECT DRIVE	7
DIRECT DRIVE PERFORMANCE DATA	8-9
DX061-DX081   ENHANCED DIRECT DRIVE	10
DX111-DX121   ENHANCED DIRECT DRIVE	11
DX141-DX161   ENHANCED DIRECT DRIVE	12
DX181-DX241   ENHANCED DIRECT DRIVE	13
BELT DRIVE PERFORMANCE DATA	14
DX06B   BELT DRIVE	15-16
DX08B   BELT DRIVE	17-18
DX11B   BELT DRIVE	19-20
DX12B   BELT DRIVE	21-22
DX14B   BELT DRIVE	23-24
DX16B   BELT DRIVE	25-26
DX18B   BELT DRIVE	27-28
DX24B   BELT DRIVE	29-30
DX27B   BELT DRIVE	31-32
DX30B   BELT DRIVE	33-34
DX36B   BELT DRIVE	35-36
KB420   BELT DRIVE	37-38
JB48   BELT DRIVE	39-40
MB542   BELT DRIVE	41-42

# INTRODUCTION

## Domex Centrifugal Fans

Domex fans are ideal for general purpose exhaust applications including: bathrooms, garages, general kitchen areas, offices, churches, dormitories, factories, large warehouses, and other relatively clean air applications.

They feature a weather-resistant, seamless spun aluminum housing which works in conjunction with a patented wheel design and deeply spun inlets to provide smooth quiet airflow through the ventilator. The centrifugal wheels are aluminum, nonoverloading, backward inclined, robotically welded, and dynamically balanced. The optional high wind construction makes Domex fans particularly suited for high wind hurricane zones.



*Belt Drive Domex*



*Direct Drive Domex*

### Direct Drive Units

**Model: DX (V/S/R/Q/Q1/Q2)**

- Static pressure up to 1.25" wg.
- Flow capacity up to 4,561 CFM.
- High wind construction (-HW) option available.

### Standard Duty Belt Drive Units

**Model: DX (B)**

- Static pressure up to 1.5" wg.
- Flow capacity up to 19,442 CFM
- High wind construction (-HW) option available.

### High Capacity Belt Drive Units

**Model: KB, JB, MB**

- Static pressure up to 1.5" wg.
- Flow capacity up to 39,169 CFM

# CERTIFICATIONS & LISTINGS



## AMCA Certification

PennBarry certifies that the Domex direct drive and belt drive models shown herein are licensed to bear the AMCA seal. The ratings shown are based on tests and procedures performed in accordance with AMCA publication 211 and AMCA publication 311 and comply with the requirements of the AMCA Certified Ratings Program. DX27B is not AMCA Certified.



PennBarry certifies that the Domex high capacity models shown herein on pages 37 - 42 are licensed to bear the AMCA seal. The ratings shown are based on tests and procedures performed in accordance with AMCA publication 211 and comply with the requirements of the AMCA Certified Ratings Program.



## cULus Certification

Domex fans carry the UL label, UL705, (ZACT / ZACT7), file #E28413.



## High Velocity Hurricane Zone (HVHZ)

Miami-Dade NOA # 17-0112.06  
Florida Product Approval #21559



WARNING

*To fulfill our obligations towards Article 33, in accordance to European REACH Regulation No 1907/2006 EC, we hereby inform you that this article contains the following Substances of Very High Concern mentioned on the Candidate list:*

- Lead

# DX06, DX08, DX10, & DX11 | DIRECT DRIVE

## Performance Data Overview

Domex direct drive models are available with single and multi-speed motors. Multi-speed motors are designated V (1050 RPM), S (1300 RPM), and R (1550 RPM). DX06R and DX18V are exceptions being single speed motors. Q, Q1, Q2 (1725/1760 RPM) are single speed motors. A single Domex fan may be made suitable for several requirements by a simple wiring change. Domex direct drive models are available in seven sizes (6, 8, 10, 11, 13, 16 and 18). Capacities range from below 150 CFM to above 4500 CFM, with static pressures beyond 1 1/4".

Performances in 50 Hz applications will be less than shown below; consult with local PennBarry representative.

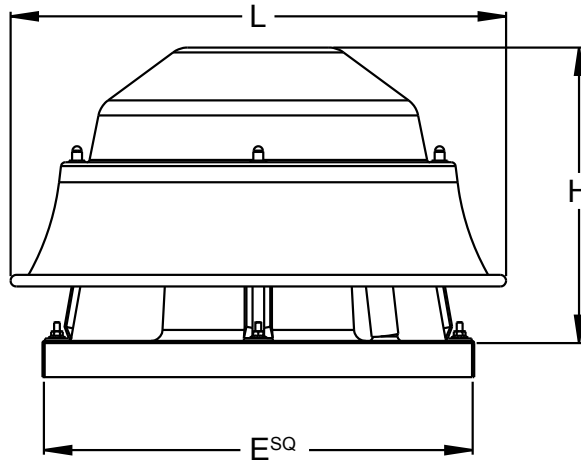

Model	Dimensions			
	L (Dia.)	H	E*	Ro
DX06R	18 7/8"	12 3/8"	18 1/2" x 18 1/2"	9 x 9"
DX08V/S/R/Q	20 7/8"	13 3/8"	18 1/2" x 18 1/2"	9 x 9"
DX10V/S/R/Q	20 7/8"	13 3/8"	18 1/2" x 18 1/2"	11 1/2" x 11 1/2"
DX11V/S/R	20 7/8"	13 3/8"	18 1/2" x 18 1/2"	11 1/2" x 11 1/2"
DX11Q	20 7/8"	13 3/8"	18 1/2" x 18 1/2"	11 1/2" x 11 1/2"

All dimensions are in inches. \*Outside dimension of curb should be 1 1/2" less than "E" dimension

Model	Nominal			Tip Speed FPM	0.000" SP		0.125" SP		0.250" SP		0.375" SP		0.500" SP		0.625" SP		0.750" SP		0.875" SP		1.000" SP		1.250" SP	
	HP	Max Watts	RPM		CFM	Sones	CFM	Sones	CFM	Sones	CFM	Sones	CFM	Sones	CFM	Sones	CFM	Sones	CFM	Sones	CFM	Sones	CFM	Sones
DX06R	1/100	52	1550	2841	146	4.3	100	3.6	69	3.4	-	-	-	-	-	-	-	-	-	-	-	-	-	-
DX08V	1/6	-(4)	1050	1649	191	0.3	111	0.8	54	0.8	-	-	-	-	-	-	-	-	-	-	-	-	-	-
DX8S	1/50	44	1300	3361	237	1.5	161	2.2	114	3	69	3.8	-	-	-	-	-	-	-	-	-	-	-	-
DX8R	1/30	55	1550	4007	285	2.4	199	2.8	142	3.5	95	4.1	58	4.9	-	-	-	-	-	-	-	-	-	-
DX8Q	1/6	-(4)	1725	4460	317	3.3	237	3.4	180	4	134	4	95	4	63	4	26	4	-	-	-	-	-	-
DX10V	1/6	-(4)	1050	2715	311	2	230	2.3	166	2.9	118	2.9	61	2.9	-	-	-	-	-	-	-	-	-	-
DX10S	1/25	82	1300	3361	385	3.9	316	3.5	257	4.8	207	5.1	168	5.2	129	5.6	82	6.1	-	-	-	-	-	-
DX10R	1/12(1)	121	1550	4007	559	6.1	501	5.9	446	6.1	394	6.5	338	6.8	267	7	187	7.2	100	7.4	-	-	-	-
DX10Q	1/6	-(4)	1725	4460	622	7.5	569	7.4	521	7.6	472	7.8	425	8.3	373	8.5	312	8.5	239	8.5	166	8.5	-	-
DX11V	1/25	111	1050	2715	388	1.8	-	2.2	148	3.1	112	3.7	80	4.5	49	5.3	-	-	-	-	-	-	-	-
DX11S	1/11	142	1300	3786	503	3.4	397	3.6	320	4.3	262	5	201	5.5	149	6	104	6.5	-	-	-	-	-	-
DX11R	1/6(2)	201	1550	4514	736	6.7	659	6.4	577	6.6	502	6.9	432	7.6	356	7.9	274	7.9	188	7.9	100	7.9	-	-
DX11Q	1/5(3)	268	1725	5024	997	9.7	921	9.7	850	9.5	768	9.5	685	9.4	598	9.2	511	9	409	8.7	294	8.9	100	8

- (1) TE motor is 1/6 Hp.
- (2) TE motor is 1/7 Hp.
- (3) EXP motor is 1/4 Hp.
- (4) Available on EC Motor only.

Performance certified is for installation Type A: Free Inlet, Free Outlet. Speed (RPM) shown is nominal. Performance is based on actual speed of test. The sound ratings shown are for loudness values in fan sones at 5'0" (1.5m) in a hemispherical free field calculated per AMCA International Standard 301. Values shown are for installation Type A: free inlet hemispherical sone levels. Performance ratings do not include the effects of appurtenances (accessories). Domex fans are only one component of a total system. As such, fan performance is directly affected by the system. It is critical that system designers determine the actual system loss to ensure that the actual flow is specified in the system design.

# DX13 | DIRECT DRIVE

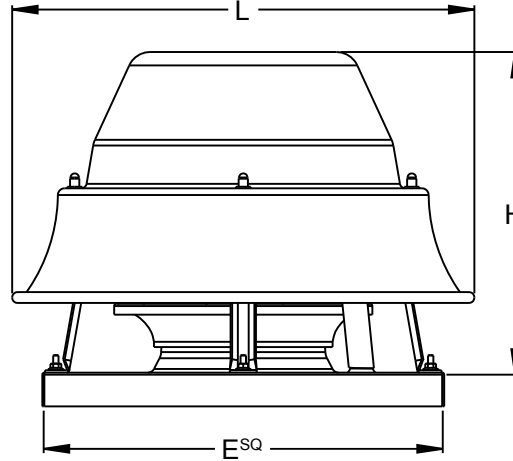

Model	Dimensions			
	L (Dia.)	H	E*	Ro
DX13V/S/R	21 7/16	14 3/4	18 1/2 x 18 1/2	11 1/2 x 11 1/2
DX13Q	21 7/16	14 3/4	18 1/2 x 18 1/2	11 1/2 x 11 1/2

All dimensions are in inches. \*Outside dimension of curb should be 1 1/2" less than "E" dimension.

Model	Nominal			Tip Speed FPM	0.000" SP		0.125" SP		0.250" SP		0.375" SP		0.500" SP		0.625" SP		0.750" SP		0.875" SP		1.000" SP		1.250" SP	
	HP	Max Watts	RPM		CFM	Sones	CFM	Sones	CFM	Sones	CFM	Sones	CFM	Sones	CFM	Sones	CFM	Sones	CFM	Sones	CFM	Sones	CFM	Sones
DX13V	1/20	92	1050	3221	661	4.4	479	3.1	341	2.8	262	3.6	207	4.3	161	5.1	115	5.9	79	6.6	44	7.4	-	-
DX13S	1/12	120	1300	3988	869	8	749	6.4	632	5.3	510	5.4	418	6	349	6.4	290	6.7	226	7	158	7.4	-	-
DX13R	1/6	201	1550	4755	1054	10.5	988	9.9	917	9.2	839	8.9	736	8.5	651	8.2	579	7.9	510	7.9	428	8	191	8.5
DX13Q	1/4	314	1725	5292	1280	16	1226	15.3	1170	14.6	1112	14	1053	13.4	995	13	936	12.5	868	12	796	11.5	630	11

Performance certified is for installation Type A: Free Inlet, Free Outlet. Speed (RPM) shown is nominal. Performance is based on actual speed of test. The sound ratings shown are for loudness values in fan sones at 5'0" (1.5m) in a hemispherical free field calculated per AMCA International Standard 301. Values shown are for installation Type A: free inlet hemispherical sone levels. Performance ratings do not include the effects of appurtenances.

Domex fans are only one component of a total system. As such, fan performance is directly affected by the system. It is critical that system designers determine the actual system loss to ensure that the actual flow is specified in the system design.

# DX16 & DX18 | DIRECT DRIVE

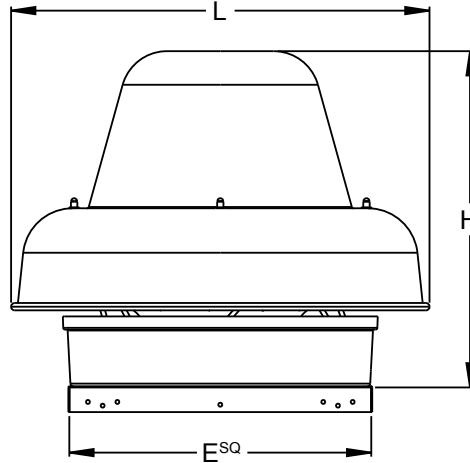

Model	Dimensions			
	L (Dia.)	H	E*	Ro
DX16V/S/R, Q1 & Q2	28 ½	22 ½	20 ½ x 20 ½	16 x 16
DX18V	39	31	28 ½ x 28 ½	20 x 20

All dimensions are in inches. \*Outside dimension of curb should be 1 ½" less than "E" dimension.

Model	Nominal			Tip Speed FPM	0.000" SP		0.125" SP		0.250" SP		0.375" SP		0.500" SP		0.625" SP		0.750" SP		0.875" SP		1.000" SP		1.250" SP	
	HP	Max Watts	RPM		CFM	Sones	CFM	Sones	CFM	Sones	CFM	Sones	CFM	Sones	CFM	Sones	CFM	Sones	CFM	Sones	CFM	Sones	CFM	Sones
DX16V	1/6	453	1050	3788	1738	9.9	1489	8	1256	6.6	1032	6.1	884	6.6	772	7.1	682	7.9	598	9.9	529	10.1	392	10.2
DX16S	1/3	510	1300	4690	2021	12	1822	10.6	1637	9.5	1428	8.7	1256	8.4	1094	8.5	943	9.3	850	10.2	775	11	606	12.3
DX16R	1/3 <sup>(1)</sup>	574	1550	5592	2346	13.8	2176	12.8	2014	12	1853	11.3	1685	10.7	1532	10.4	1384	10.1	1247	10	1115	10.4	881	12.4
DX16Q1	1/2	688	1650	5953	2701	16.9	2576	16.4	2465	15.9	2352	15.5	2228	15	2096	14.4	1966	14	1839	13.6	1700	13.5	1401	13.5
DX16Q2	3/4	866	1725	6223	3016	17.7	2921	17.1	2829	16.7	2747	16.3	2665	15.9	2575	15.5	2484	15	2371	14.6	2256	14.2	2005	13.3
DX18V	3/4	964	1075	6029	4561	21	4395	19.8	4230	19.1	4053	18.5	3865	17.9	3671	16.9	3454	16.4	3237	16.4	2995	16.4	2405	16.4

(1) TE motor is 1/2 Hp.

Performance certified is for installation Type A: Free Inlet, Free Outlet. Speed (RPM) shown is nominal. Performance is based on actual speed of test. The sound ratings shown are for loudness values in fan sones at 5'0" (1.5m) in a hemispherical free field calculated per AMCA International Standard 301. Values shown are for installation Type A: free inlet hemispherical sone levels. Performance ratings do not include the effects of appurtenances.

Domex fans are only one component of a total system. As such, fan performance is directly affected by the system. It is critical that system designers determine the actual system loss to ensure that the actual flow is specified in the system design.

# DIRECT DRIVE PERFORMANCE DATA

## Domex Fan Curves

The fan curves illustrated here show the range of capacities available for direct drive units. Each graph shows the performance of several models at one particular nominal speed. Fan curves provide a quick method for selecting a fan unit based on design point requirements.

The direct drive performance charts on the previous pages provide the tabular data (CFM and static pressure) used to plot the fan curves. In addition, the horsepower, tip speed and sones are tabulated. Since sound is normally an important factor in the selection of a fan, an engineer will usually want to select the "slowest" unit which meets CFM and SP requirements.

Please refer to the Motor Selection section to make sure the motor you select meets your electrical requirements.

*Domex fans are only one component of a total system. As such, fan performance is directly affected by the system. It is critical that system designers determine the actual system loss to ensure that the actual flow is specified in the system design.*

Nominal 1075 RPM

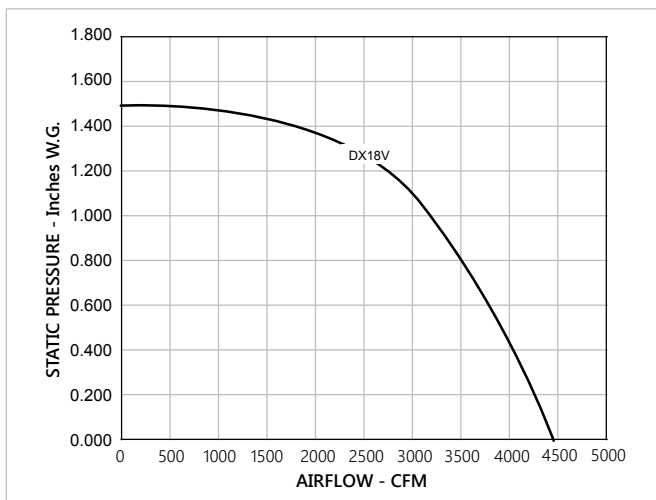

Nominal 1050 RPM

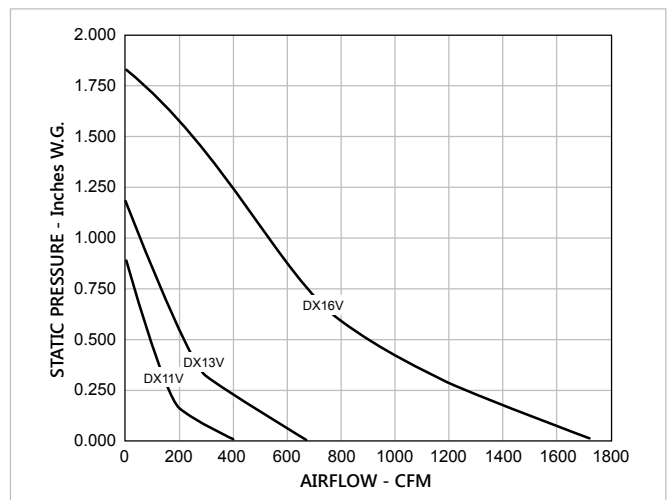

Nominal 1550 RPM

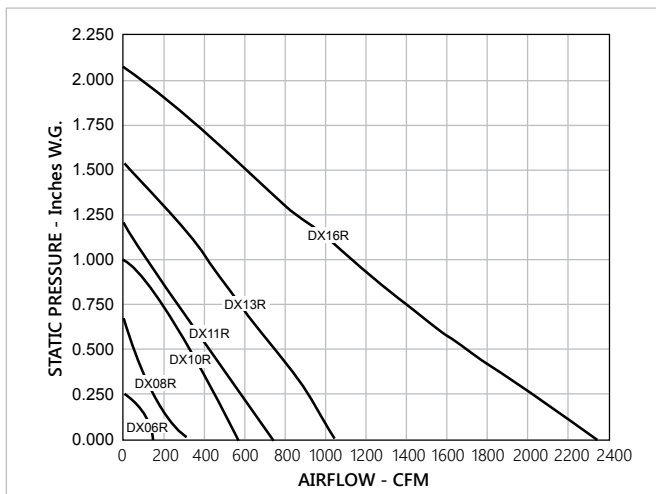

Nominal 1300 RPM

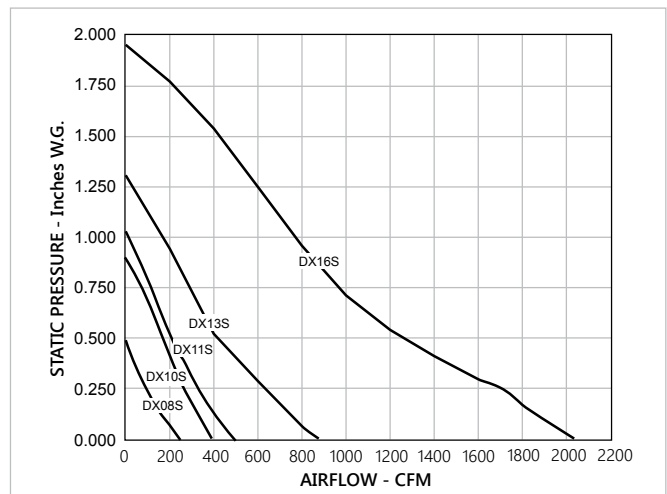



# DIRECT DRIVE PERFORMANCE DATA

## Nominal 1725 RPM

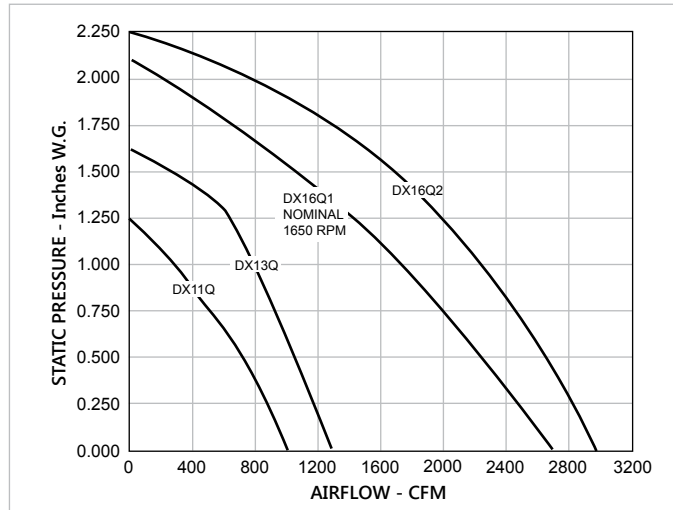

# DX061-DX081 | ENHANCED DIRECT DRIVE

## DX061

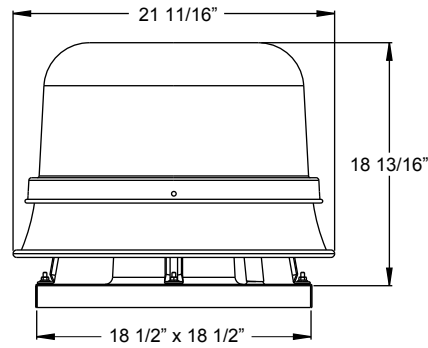

Model	HP	RPM	0.000" SP		0.250" SP		0.500" SP		0.750" SP		1.000" SP	
			CFM	Sones	CFM	Sones	CFM	Sones	CFM	Sones	CFM	Sones
DX061LGP	1/6	500	311	2.3	-	-	-	-	-	-	-	-
DX061MGP	1/6	690	429	3.4	-	-	-	-	-	-	-	-
DX061WGP	1/6	860	534	4.7	190	3.8	-	-	-	-	-	-
DX061VGP	1/6	1050	653	6.5	424	5.3	-	-	-	-	-	-
DX061SGP	1/4	1300	808	7.3	639	6.4	387	6.1	-	-	-	-
DX061RGP	1/2	1550	963	9.2	828	9.1	662	8.3	419	8.3	-	-
DX061Q1GP	1/2	1650	1025	10.3	899	10.1	751	9.5	547	9.2	245	9.3
DX061Q2GP	1/2	1725	1072	11.1	952	10.9	813	10.6	635	10.6	388	10.1

Performance certified is for installation Type A: Free Inlet, Free Outlet. Speed (RPM) shown is nominal. Performance is based on actual speed of test. The sound ratings shown are for loudness values in fan sones at 5'0" (1.5m) in a hemispherical free field calculated per AMCA International Standard 301. Values shown are for Installation Type A: free inlet hemispherical sone levels. Performance ratings do not include the effects of appurtenances.

Domex fans are only one component of a total system. As such, fan performance is directly affected by the system. It is critical that system designers determine the actual system loss to ensure that the actual flow is specified in the system design.

## DX081

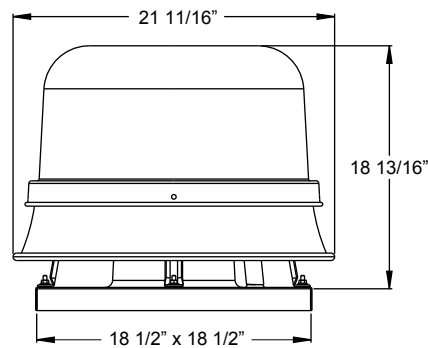

Model	HP	RPM	0.000" SP		0.250" SP		0.500" SP		0.750" SP		1.000" SP		1.250" SP	
			CFM	Sones	CFM	Sones	CFM	Sones	CFM	Sones	CFM	Sones	CFM	Sones
DX081LGP	1/6	500	386	2.3	-	-	-	-	-	-	-	-	-	-
DX081MGP	1/6	690	532	3.8	-	-	-	-	-	-	-	-	-	-
DX081WGP	1/6	860	664	5.3	423	3.9	-	-	-	-	-	-	-	-
DX081VGP	1/6	1050	810	7.5	625	6	340	5.2	-	-	-	-	-	-
DX081SGP	1/4	1300	1003	10.8	858	9.1	692	8.2	448	7.9	-	-	-	-
DX081RGP	1/2	1550	1196	13.9	1078	12.9	947	11.6	802	11	609	10.9	-	-
DX081Q1GP	1/2	1650	1273	15	1164	14.2	1041	12.9	910	11.8	757	11.8	508	11.8
DX081Q2GP	1/2	1725	1331	16.6	1227	15.7	1110	14.6	987	13.1	853	13.1	669	13.1

Performance certified is for installation Type A: Free Inlet, Free Outlet. Speed (RPM) shown is nominal. Performance is based on actual speed of test. The sound ratings shown are for loudness values in fan sones at 5'0" (1.5m) in a hemispherical free field calculated per AMCA International Standard 301. Values shown are for Installation Type A: free inlet hemispherical sone levels. Performance ratings do not include the effects of appurtenances.

Domex fans are only one component of a total system. As such, fan performance is directly affected by the system. It is critical that system designers determine the actual system loss to ensure that the actual flow is specified in the system design.

# DX111-DX121 | ENHANCED DIRECT DRI

## DX111

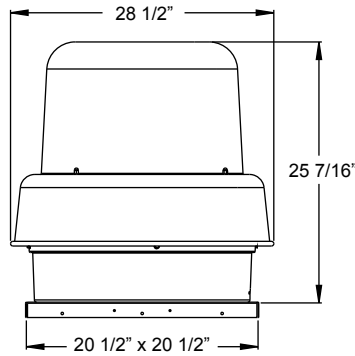

Model	HP	RPM	0.000" SP		0.250" SP		0.500" SP		0.750" SP		1.000" SP		1.250" SP		1.500" SP	
			CFM	Sones	CFM	Sones	CFM	Sones	CFM	Sones	CFM	Sones	CFM	Sones	CFM	Sones
DX111LGP	1/6	500	862	2.8	-	-	-	-	-	-	-	-	-	-	-	-
DX111MGP	1/6	690	1190	5.3	696	4.1	-	-	-	-	-	-	-	-	-	
DX111WGP	1/6	860	1483	7.4	1148	6.4	-	-	-	-	-	-	-	-	-	
DX111VGP	1/4	1050	1811	9.8	1553	8.5	1216	7.5	-	-	-	-	-	-	-	
DX111SGP	1/2	1300	2242	13	2040	12.1	1809	10.8	1526	10	1066	9.9	-	-	-	
DX111RGP	3/4	1550	2673	16.9	2508	16.3	2326	15.5	2124	14.2	1889	13.5	1581	13.7	1099	13.8

Performance certified is for installation Type A: Free Inlet, Free Outlet. Speed (RPM) shown is nominal. Performance is based on actual speed of test. The sound ratings shown are for loudness values in fan sones at 5'0" (1.5m) in a hemispherical free field calculated per AMCA International Standard 301. Values shown are for Installation Type A: free inlet hemispherical sone levels. Performance ratings do not include the effects of appurtenances.

Fumex fans are only one component of a total system. As such, fan performance is directly affected by the system. It is critical that system designers determine the actual system loss to ensure that the actual flow is specified in the system design.

## DX121

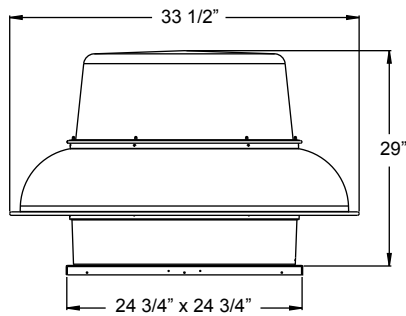

Model	HP	RPM	0.000" SP		0.250" SP		0.500" SP		0.750" SP		1.000" SP	
			CFM	Sones	CFM	Sones	CFM	Sones	CFM	Sones	CFM	Sones
DX121LGP	1/6	500	976	4.9	-	-	-	-	-	-	-	-
DX121MGP	1/6	690	1346	9.2	873	8.4	-	-	-	-	-	-
DX121WGP	1/6	860	1678	11.9	1331	10.6	814	10.1	-	-	-	-
DX121VGP	1/3	1050	2049	14.2	1763	13	1454	12.2	980	12	-	-
DX121SGP	3/4	1300	2537	18.1	2316	17.1	2076	17.1	1820	16.2	1490	16.2

Performance certified is for installation Type A: Free Inlet, Free Outlet. Speed (RPM) shown is nominal. Performance is based on actual speed of test. The sound ratings shown are for loudness values in fan sones at 5'0" (1.5m) in a hemispherical free field calculated per AMCA International Standard 301. Values shown are for Installation Type A: free inlet hemispherical sone levels. Performance ratings do not include the effects of appurtenances.

Domex fans are only one component of a total system. As such, fan performance is directly affected by the system. It is critical that system designers determine the actual system loss to ensure that the actual flow is specified in the system design.

# DX141-DX161 | ENHANCED DIRECT DRIVE

## DX141

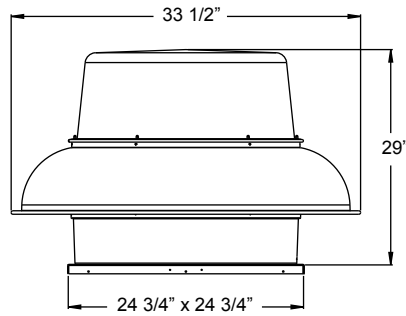

Model	HP	RPM	0.000" SP		0.250" SP		0.500" SP		0.750" SP		1.000" SP		1.250" SP		1.500" SP		1.750" SP		2.000" SP		
			CFM	Sones	CFM	Sones	CFM	Sones	CFM	Sones	CFM	Sones	CFM	Sones	CFM	Sones	CFM	Sones	CFM	Sones	CFM
DX141LGP	1/6	500	1360	4.7	-	-	-	-	-	-	-	-	-	-	-	-	-	-	-	-	-
DX141MGP	1/6	690	1877	7.5	1253	6.2	-	-	-	-	-	-	-	-	-	-	-	-	-	-	-
DX141WGP	1/4	860	2340	9.9	1894	8.5	1223	6.4	-	-	-	-	-	-	-	-	-	-	-	-	-
DX141VGP	1/2	1050	2857	13.5	2510	12.4	2067	10.9	1478	8.5	-	-	-	-	-	-	-	-	-	-	-
DX141SGP	3/4	1300	3537	19	3255	18	2964	17	2586	15.6	2165	13.4	-	-	-	-	-	-	-	-	-
DX141RGP	1 1/2*	1550	4217	22.7	3980	21.9	3747	20.9	3488	19.9	3174	18.8	2831	17.5	2461	16.3	1820	15.7	-	-	-
DX141Q1GP	1 1/2*	1650	4489	23.3	4267	22.5	4047	21.6	3823	20.7	3547	19.7	3229	18.5	2906	17.7	2539	17.1	1859	17	-
DX141Q2GP	2	1725	4693	24.9	4481	24.1	4270	23.3	4061	22.5	3806	21.5	3518	20.5	3211	19.4	2888	18.7	2477	17.9	-

\*Single phase motor available on 2HP.

Performance certified is for installation Type A: Free Inlet, Free Outlet. Speed (RPM) shown is nominal. Performance is based on actual speed of test. The sound ratings shown are for loudness values in fan sones at 5'0" (1.5m) in a hemispherical free field calculated per AMCA International Standard 301. Values shown are for Installation Type A: free inlet hemispherical sone levels. Performance ratings do not include the effects of appurtenances.

Domex fans are only one component of a total system. As such, fan performance is directly affected by the system. It is critical that system designers determine the actual system loss to ensure that the actual flow is specified in the system design.

## DX161

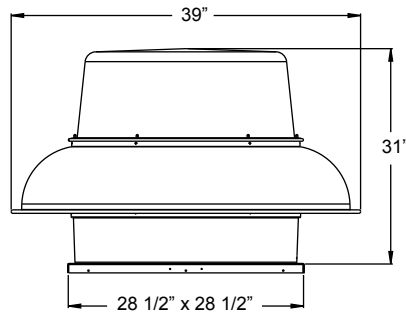

Model	HP	RPM	0.000" SP		0.250" SP		0.500" SP		0.750" SP		1.000" SP		1.250" SP		1.500" SP		1.750" SP				
			CFM	Sones	CFM	Sones	CFM	Sones	CFM	Sones	CFM	Sones	CFM	Sones	CFM	Sones	CFM	Sones	CFM	Sones	
DX161LGP	1/6	500	2081	6.4	1320	5.5	-	-	-	-	-	-	-	-	-	-	-	-	-	-	-
DX161MGP	1/3	690	2872	10.4	2430	9.6	1655	8.8	-	-	-	-	-	-	-	-	-	-	-	-	-
DX161WGP	3/4	860	3580	14.1	3233	13.4	2860	12.5	2213	11.3	-	-	-	-	-	-	-	-	-	-	-
DX161VGP	1*	1050	4371	18.6	4092	18	3795	17	3486	16.3	3069	15.4	-	-	-	-	-	-	-	-	-
DX161SGP	2	1300	5412	24.4	5186	23.9	4956	23.2	4714	22.4	4466	21.5	4202	20.7	3870	19.8	3210	18	-	-	-

\*Single phase motor available on 2HP.

Performance certified is for installation Type A: Free Inlet, Free Outlet. Speed (RPM) shown is nominal. Performance is based on actual speed of test. The sound ratings shown are for loudness values in fan sones at 5'0" (1.5m) in a hemispherical free field calculated per AMCA International Standard 301. Values shown are for Installation Type A: free inlet hemispherical sone levels. Performance ratings do not include the effects of appurtenances.

Domex fans are only one component of a total system. As such, fan performance is directly affected by the system. It is critical that system designers determine the actual system loss to ensure that the actual flow is specified in the system design.

# DX181-DX241 | ENHANCED DIRECT DRIVE

## DX181

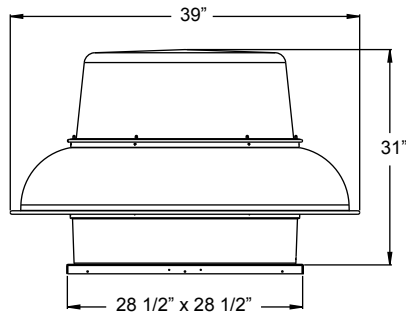

Model	HP	RPM	0.000" SP		0.250" SP		0.500" SP		0.750" SP		1.000" SP		1.250" SP	
			CFM	Sones	CFM	Sones	CFM	Sones	CFM	Sones	CFM	Sones	CFM	Sones
DX181LGP	1/6	500	2634	7	1669	6.1	-	-	-	-	-	-	-	-
DX181MGP	1/2	690	3635	11.5	3055	10.5	2138	8.8	-	-	-	-	-	-
DX181WGP	3/4	860	4530	16.2	4074	15.4	3587	13.9	2813	11.8	-	-	-	-
DX181VGP	1 1/2*	1050	5531	21.7	5165	21.3	4775	20.1	4372	18.7	3857	17.1	2690	15.9

\*Single phase motor available on 2HP.

Performance certified is for installation Type A: Free Inlet, Free Outlet. Speed (RPM) shown is nominal. Performance is based on actual speed of test. The sound ratings shown are for loudness values in fan sones at 5'0" (1.5m) in a hemispherical free field calculated per AMCA International Standard 301. Values shown are for Installation Type A: free inlet hemispherical sone levels. Performance ratings do not include the effects of appurtenances.

Fumex fans are only one component of a total system. As such, fan performance is directly affected by the system. It is critical that system designers determine the actual system loss to ensure that the actual flow is specified in the system design.

## DX241

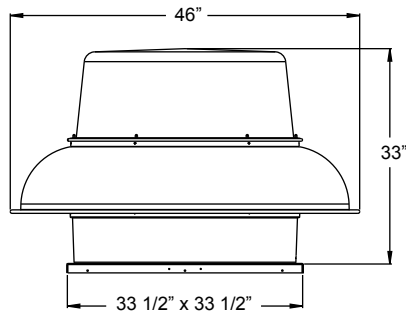

Model	HP	RPM	0.000" SP		0.250" SP	
			CFM	Sones	CFM	Sones
DX241LGP	1/2	500	4806	10.1	3913	8.6

\*Single phase motor available on 2HP.

Performance certified is for installation Type A: Free Inlet, Free Outlet. Speed (RPM) shown is nominal. Performance is based on actual speed of test. The sound ratings shown are for loudness values in fan sones at 5'0" (1.5m) in a hemispherical free field calculated per AMCA International Standard 301. Values shown are for Installation Type A: free inlet hemispherical sone levels. Performance ratings do not include the effects of appurtenances.

Domex fans are only one component of a total system. As such, fan performance is directly affected by the system. It is critical that system designers determine the actual system loss to ensure that the actual flow is specified in the system design.

# BELT DRIVE PERFORMANCE DATA

## Performance Data

The belt drive models shown on the following pages have sizes and capacities ranging from below 300 CFM to above 39,000 CFM, with static pressures from 0" to above 1.5". All models are available with a wide range of horsepower sizes and RPM's.

The data provided for each belt drive model includes:

- Elevation Drawing Showing Overall Dimensions
- Fan Curve Graph
- Performance Chart

Each curve graphically displays the range of capacities available for each model, in most cases beyond the specifics shown in the tabular data. The maximum performance afforded by each horsepower is indicated by dashed lines and the RPM is indicated by solid lines.

Some models have graphs that show both shaded and unshaded areas. Selection should be made from the unshaded area only. Shaded areas reflect unstable performance ("surge"), a characteristic typical of backward inclined wheels, and should be avoided. These unstable regions are not shown in the tabular data.

The highest RPM shown for a specific horsepower in the tabular data is the maximum speed that for any point along the performance curve the BHP will not exceed the available horsepower.

It is important to note that, while it is common industry-wide practice to exceed a "nominal" horsepower by using a motor's service factor, PennBarry uses a conservative portion of the service factor, allowing half to remain a true "safety" factor.

Use the Motor Availability chart (see Product Guide) to select motor enclosures and voltages which can be installed in the fans.

*Note: Domex fans are only one component of a total system. As such, performance is directly affected by the system. It is critical that system designers determine actual system losses to ensure that the actual flow is specified in the system range.*

## Belt Drive Losses

The AMCA Review Committee has developed the chart shown below for the purpose of estimating belt drive losses. To calculate total BHP (including drive losses): Find the BHP of your operating point on the x-axis on the graph below. Follow the vertical line to the curves indicating the range of drive losses. Look at the y-axis on the left and find the drive loss percentage. Calculate the total BHP by adding the drive loss to the operating point BHP. For BHP's below 0.3, use 30%.

## Drive Loss Reference Chart

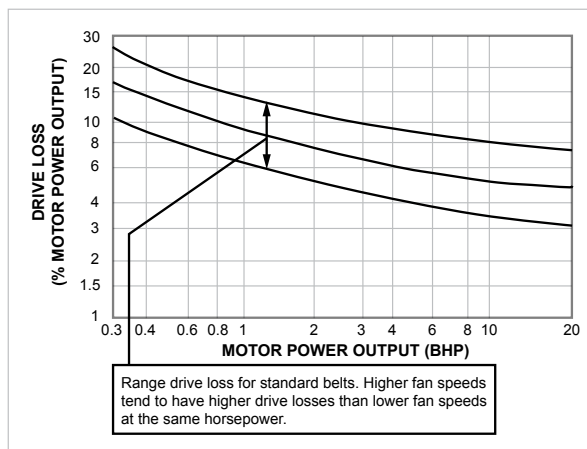

For totally enclosed, explosion proof, multi-speed and all 1.0 Service Factor motors, fan BHP plus drive losses should not exceed motor rated HP.

Graph reprinted from AMCA publication 203, with the express written permission from the Air Movement and Control Association, Inc., 30 West University Drive, Arlington Heights, IL 60004-1983.

# DX06B | BELT DRIVE

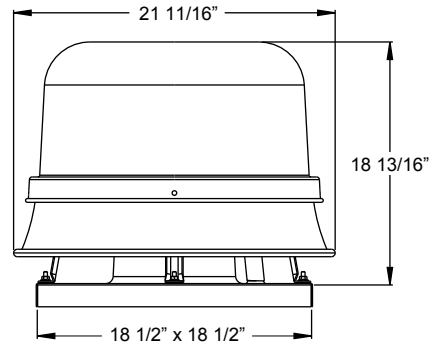
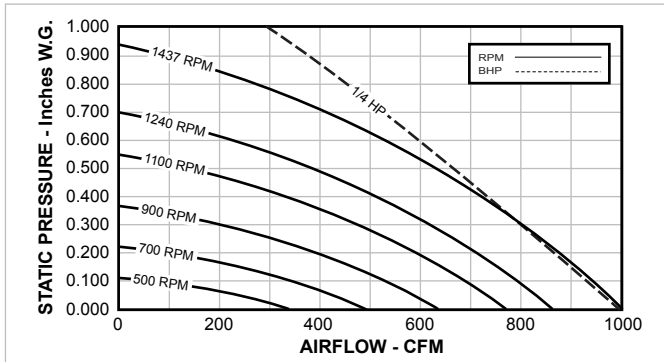

HP	RPM	Tip Speed FPM	0.000" SP		0.125" SP		0.250" SP		0.375" SP		0.500" SP		0.625" SP	
			CFM		CFM		CFM		CFM		CFM		CFM	
			Sones	BHP	Sones	BHP	Sones	BHP	Sones	BHP	Sones	BHP	Sones	BHP
1/4	375	1080	218		-		-		-		-		-	
			0.6	0.047	-		-		-		-		-	
	430	1238	250		-		-		-		-		-	
			0.9	0.005	-		-		-		-		-	
	475	1368	276		-		-		-		-		-	
			1.2	0.006	-		-		-		-		-	
	520	1497	302		-		-		-		-		-	
			1.6	0.008	-		-		-		-		-	
	565	1627	328		-		-		-		-		-	
			2.2	0.011	-		-		-		-		-	
	610	1757	355		58		-		-		-		-	
			2.6	0.014	2.0	0.007	-		-		-		-	
	655	1886	381		143		-		-		-		-	
			3.1	0.017	2.9	0.012	-		-		-		-	
	700	2016	407		197		-		-		-		-	
			3.7	0.020	3.6	0.016	-		-		-		-	
	745	2145	433		244		-		-		-		-	
			4.1	0.025	4.0	0.021	-		-		-		-	
790	2275	459		290		-		-		-		-		
		4.6	0.029	4.5	0.026	-		-		-		-		
835	2405	485		329		-		-		-		-		
		5.2	0.035	5.1	0.031	-		-		-		-		
880	2534	511		366		124		-		-		-		
		5.8	0.041	5.9	0.037	5.8	0.026	-		-		-		
925	2664	538		400		200		-		-		-		
		6.3	0.047	6.3	0.044	6.2	0.034	-		-		-		
970	2793	564		434		256		-		-		-		
		6.9	0.054	6.8	0.051	6.6	0.042	-		-		-		
1015	2923	590		467		305		-		-		-		
		7.5	0.062	7.4	0.059	7.3	0.051	-		-		-		
1060	3053	616		500		352		110		-		-		
		8.3	0.071	8.2	0.067	8.3	0.061	8.2	0.040	-		-		
1105	3182	642		532		398		202		-		-		
		9.1	0.080	9.0	0.077	9.4	0.070	9.3	0.055	-		-		

# DX06B | BELT DRIVE

HP	RPM	Tip Speed FPM	0.000" SP		0.125" SP		0.250" SP		0.375" SP		0.500" SP		0.625" SP	
			CFM		CFM		CFM		CFM		CFM		CFM	
			Sones	BHP	Sones	BHP	Sones	BHP	Sones	BHP	Sones	BHP	Sones	BHP
1/4	1150	3312	668		564		440		268		-		-	
			9.7	0.091	9.7	0.087	10.2	0.081	9.6	0.067	-	-	-	-
	1195	3441	694		595		477		321		-		-	
			10.4	0.102	10.4	0.098	10.9	0.092	10.2	0.080	-	-	-	-
	1240	3571	721		625		514		370		166		-	
			11.2	0.114	11.2	0.110	11.8	0.104	11.6	0.093	11.6	0.070	-	-
	1280	3686	744		652		545		412		240		-	
			12.1	0.125	12.3	0.122	13.0	0.115	12.9	0.106	12.9	0.087	-	-

Performance certified is for installation type A: Free Inlet, Free Outlet. Power rating (BHP) does not include transmission losses. For further information on estimating belt drive losses and motor service factors see page 13. The sound ratings shown are for loudness values in fan sones at 5'0" (1.5m) in a hemispherical free field calculated per AMCA International Standard 301. Values shown are for installation Type A: free inlet hemispherical sone levels. Performance ratings do not include the effects of appurtenances.



# DX08B | BELT DRIVE

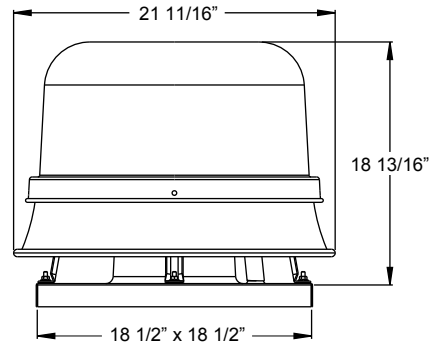
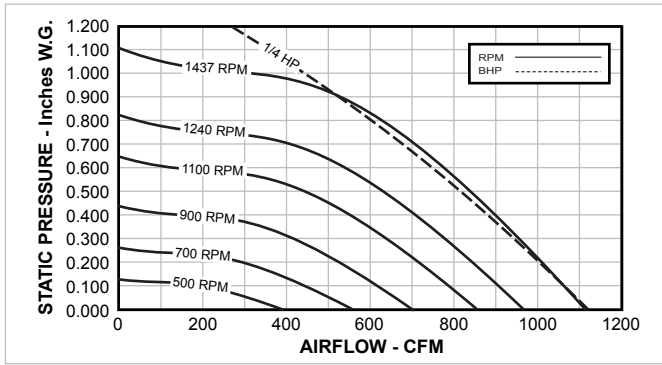

HP	RPM	Tip Speed FPM	0.000" SP		0.125" SP		0.250" SP		0.375" SP		0.500" SP		0.625" SP		0.750" SP	
			CFM		CFM		CFM		CFM		CFM		CFM		CFM	
			Sones	BHP	Sones	BHP	Sones	BHP	Sones	BHP	Sones	BHP	Sones	BHP	Sones	BHP
1/4	375	1150	289		-		-		-		-		-		-	
			1.4	0.01	-		-		-		-		-		-	
	430	1319	331		-		-		-		-		-		-	
			1.7	0.01	-		-		-		-		-		-	
	475	1457	366		-		-		-		-		-		-	
			2	0.01	-		-		-		-		-		-	
	520	1595	401		155		-		-		-		-		-	
			2.2	0.01	1.7	0.01	-		-		-		-		-	
	565	1733	435		242		-		-		-		-		-	
			2.5	0.02	1.9	0.02	-		-		-		-		-	
	610	1871	470		301		-		-		-		-		-	
			3.1	0.02	2.4	0.02	-		-		-		-		-	
	655	2009	505		351		-		-		-		-		-	
			3.4	0.02	2.7	0.02	-		-		-		-		-	
	700	2147	540		399		-		-		-		-		-	
			3.8	0.03	3.1	0.03	-		-		-		-		-	
	745	2285	574		444		247		-		-		-		-	
			4.3	0.03	3.5	0.04	3	0.03	-		-		-		-	
	790	2424	609		487		330		-		-		-		-	
			4.6	0.04	3.9	0.04	3.3	0.04	-		-		-		-	
835	2562	644		530		393		-		-		-		-		
		5	0.05	4.2	0.05	3.6	0.05	-		-		-		-		
880	2700	678		571		446		207		-		-		-		
		5.5	0.06	4.7	0.06	4	0.06	3.6	0.05	-		-		-		
925	2838	713		611		496		329		-		-		-		
		6	0.07	5.2	0.07	4.5	0.07	4	0.07	-		-		-		
970	2976	748		651		543		408		-		-		-		
		6.7	0.08	5.9	0.08	5.2	0.08	4.5	0.08	-		-		-		
1015	3114	783		691		590		471		236		-		-		
		7.2	0.09	6.5	0.09	5.8	0.09	5.1	0.09	4.8	0.08	-		-		
1060	3252	817		730		635		526		364		-		-		
		7.5	0.1	6.8	0.1	6.2	0.11	5.6	0.11	5.2	0.1	-		-		
1105	3390	852		769		678		577		449		-		-		
		8	0.11	7.2	0.12	6.6	0.12	6	0.12	5.5	0.12	-		-		
1150	3258	887		808		720		626		514		309		-		
		8.8	0.13	7.9	0.13	7.3	0.13	6.7	0.13	6.2	0.13	5.8	0.12	-		
1195	3666	921		846		762		673		575		426		-		
		9.8	0.14	8.8	0.15	8.1	0.15	7.6	0.15	7.1	0.15	6.7	0.14	-		
1240	3804	956		885		803		719		626		509		279		
		10.4	0.16	9.4	0.16	8.6	0.17	8.1	0.17	7.7	0.17	7.4	0.16	6.8	0.14	
1280	3927	687		918		840		760		670		566		398		
		10.5	0.17	9.6	0.18	8.9	0.18	8.3	0.19	7.9	0.19	7.6	0.18	7.3	0.17	

# DX08B | BELT DRIVE

HP	RPM	Tip Speed FPM	0.000" SP		0.125" SP		0.250" SP		0.375" SP		0.500" SP		0.625" SP		0.750" SP	
			CFM		CFM		CFM		CFM		CFM		CFM		CFM	
			Sones	BHP	Sones	BHP	Sones	BHP	Sones	BHP	Sones	BHP	Sones	BHP	Sones	BHP
1/4	1320	4049	1018		952		875		798		714		622		488	
			10.8	0.19	10	0.2	9.3	0.2	8.7	0.2	8.3	0.2	8	0.2	7.9	0.19
	1350	4141	1041		977		902		827		746		658		544	
			11.1	0.21	10.4	0.21	9.7	0.21	9	0.22	8.7	0.22	8.5	0.22	8.3	0.21
	1390	4264	1072		1010		937		865		787		704		603	
			11.7	0.22	11.1	0.23	10.3	0.23	9.7	0.23	9.1	0.24	9.1	0.24	9	0.23
	1420	4356	1095		1035		964		893		818		737		645	
			12.3	0.24	11.6	0.24	10.9	0.25	10.3	0.25	9.6	0.25	9.6	0.25	9.6	0.25
	1437	4408	1108		1049		979		909		836		756		669	
			12.5	0.25	11.8	0.25	11.1	0.26	10.5	0.26	9.9	0.26	9.8	0.26	9.8	0.26

Performance certified is for installation type A: Free Inlet, Free Outlet. Power rating (BHP) does not include transmission losses. For further information on estimating belt drive losses and motor service factors see page 13. The sound ratings shown are for loudness values in fan sones at 5'0" (1.5m) in a hemispherical free field calculated per AMCA International Standard 301. Values shown are for installation Type A: free inlet hemispherical sone levels. Performance ratings do not include the effects of appurtenances.

# DX11B | BELT DRIVE

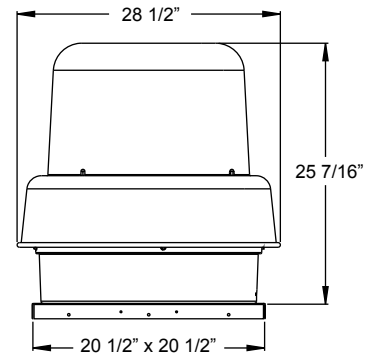
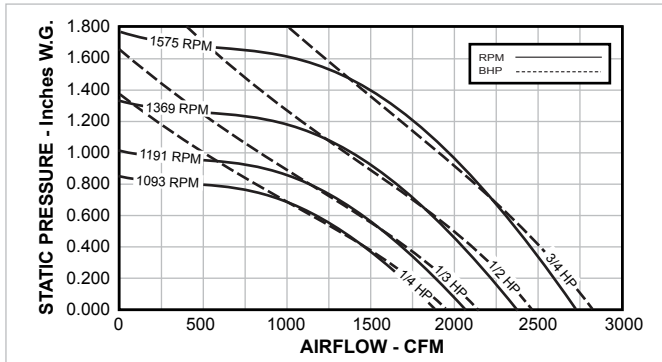

HP	RPM	Tip Speed FPM	0.000" SP		0.125" SP		0.250" SP		0.375" SP		0.500" SP		0.625" SP		0.750" SP		0.875" SP		1.000" SP		1.125" SP	
			CFM		CFM		CFM		CFM		CFM		CFM		CFM		CFM		CFM		CFM	
			Sones	BHP	Sones	BHP	Sones	BHP	Sones	BHP	Sones	BHP	Sones	BHP	Sones	BHP	Sones	BHP	Sones	BHP	Sones	BHP
1/4	650	2345	1120		905		535		-		-		-		-		-		-		-	
			4.7	0.05	4.1	0.05	3.4	0.05	-	-	-	-	-	-	-	-	-	-	-	-	-	-
	675	2435	1164		959		638		-		-		-		-		-		-		-	
			4.9	0.05	4.3	0.06	3.6	0.06	-	-	-	-	-	-	-	-	-	-	-	-	-	-
	700	2526	1207		1011		737		-		-		-		-		-		-		-	
			5.1	0.06	4.6	0.07	3.9	0.07	-	-	-	-	-	-	-	-	-	-	-	-	-	-
	725	2616	1250		1062		813		-		-		-		-		-		-		-	
			5.5	0.07	4.9	0.07	4.3	0.08	-	-	-	-	-	-	-	-	-	-	-	-	-	-
	750	2706	1293		1113		880		252		-		-		-		-		-		-	
			5.8	0.07	5.3	0.08	4.7	0.09	4.1	0.05	-	-	-	-	-	-	-	-	-	-	-	-
	800	2886	1379		1213		1007		672		-		-		-		-		-		-	
			6.6	0.09	6.1	0.10	5.5	0.10	5.0	0.10	-	-	-	-	-	-	-	-	-	-	-	-
	825	2976	1422		1263		1067		775		-		-		-		-		-		-	
			6.8	0.10	6.3	0.10	5.7	0.11	5.2	0.11	-	-	-	-	-	-	-	-	-	-	-	-
	850	3067	1465		1312		1126		874		-		-		-		-		-		-	
			7.0	0.11	6.5	0.11	5.9	0.12	5.4	0.12	-	-	-	-	-	-	-	-	-	-	-	-
900	3247	1552		1407		1238		1028		665		-		-		-		-		-		
		7.8	0.13	7.2	0.13	6.5	0.14	6.0	0.15	5.7	0.13	-	-	-	-	-	-	-	-	-	-	
950	3427	1638		1502		1347		1159		884		-		-		-		-		-		
		8.5	0.15	7.9	0.16	7.3	0.16	6.7	0.17	6.3	0.17	-	-	-	-	-	-	-	-	-	-	
1000	3608	1724		1596		1451		1282		1080		706		-		-		-		-		
		9.2	0.17	8.7	0.18	8.0	0.19	7.3	0.20	7.0	0.20	6.8	0.18	-	-	-	-	-	-	-	-	
1050	3788	1810		1689		1553		1400		1217		939		-		-		-		-		
		9.7	0.20	9.2	0.21	8.5	0.22	7.8	0.23	7.4	0.23	7.1	0.22	-	-	-	-	-	-	-	-	
1075	3878	1853		1735		1603		1456		1284		1040		647		-		-		-		
		10.0	0.21	9.4	0.23	8.8	0.23	8.1	0.24	7.7	0.25	7.4	0.25	7.5	0.21	-	-	-	-	-	-	
1093	3943	1884		1768		1639		1496		1329		1111		758		-		-		-		
		10.2	0.23	9.6	0.24	9.1	0.24	8.3	0.26	7.9	0.26	7.7	0.26	7.7	0.23	-	-	-	-	-	-	
1/3	1125	4059	1940		1827		1703		1566		1408		1227		924		-		-		-	
			10.6	0.25	10.0	0.26	9.5	0.27	8.8	0.27	8.2	0.29	8.0	0.29	8.1	0.27	-	-	-	-	-	
	1150	4149	1983		1873		1753		1621		1469		1296		1028		489		-		-	
			11.0	0.26	10.4	0.27	9.8	0.28	9.1	0.29	8.5	0.31	8.3	0.31	8.3	0.29	8.4	0.21	-	-	-	-
1191	4297	2053		1948		1834		1708		1568		1406		1193		883		-		-		
		11.5	0.29	11.0	0.30	10.5	0.31	9.8	0.32	9.0	0.34	8.8	0.34	8.6	0.34	8.6	0.31	-	-	-	-	

# DX11B | BELT DRIVE

HP	RPM	Tip Speed FPM	0.000" SP		0.125" SP		0.250" SP		0.375" SP		0.500" SP		0.625" SP		0.750" SP		0.875" SP		1.000" SP		1.125" SP					
			CFM		CFM		CFM		CFM		CFM		CFM		CFM		CFM		CFM		CFM		CFM			
			Sones	BHP	Sones	BHP	Sones	BHP	Sones	BHP	Sones	BHP	Sones	BHP	Sones	BHP	Sones	BHP	Sones	BHP	Sones	BHP	Sones	BHP		
1/2	1220	4402	2103		2001		1889		1767		1634		1481		1306		1019		-		-					
			11.9	0.31	11.4	0.33	10.9	0.34	10.2	0.34	9.6	0.36	9.2	0.37	9.0	0.37	8.9	0.34	-	-	-	-				
	1250	4510	2155		2056		1947		1829		1700		1555		1393		1142		801		-		-			
			12.4	0.34	11.9	0.35	11.4	0.36	10.8	0.37	10.0	0.38	9.6	0.39	9.4	0.39	9.3	0.38	9.3	0.33	-	-				
	1300	4690	2241		2147		2042		1930		1811		1677		1528		1342		1071		-		-			
			13.0	0.38	12.6	0.39	12.2	0.40	11.6	0.41	10.9	0.42	10.2	0.44	10.1	0.44	9.9	0.44	9.9	0.42	-	-				
	1369	4939	2360		2271		2172		2069		1959		1838		1703		1556		1352		1095		-		-	
			14.0	0.44	13.6	0.46	13.2	0.47	12.8	0.48	12.1	0.49	11.4	0.51	11.0	0.52	10.8	0.52	10.9	0.51	10.9	0.48	-	-		
3/4	1380	4979	2379		2290		2193		2091		1982		1862		1730		1585		1396		1141		-		-	
			14.1	0.45	13.8	0.47	13.4	0.48	13.0	0.49	12.3	0.50	11.6	0.52	11.1	0.53	10.9	0.53	11.0	0.52	11.1	0.50	-	-		
	1410	5087	2431		2344		2249		2150		2044		1929		1803		1666		1513		1265		-		-	
			14.6	0.48	14.2	0.50	13.8	0.51	13.5	0.52	12.8	0.53	12.1	0.55	11.5	0.56	11.4	0.56	11.4	0.57	11.5	0.54	-	-		
	1470	5304	2535		2451		2361		2268		2166		2061		1946		1818		1681		1505		-		-	
			15.6	0.55	15.2	0.56	14.8	0.58	14.5	0.58	13.9	0.60	13.2	0.61	12.6	0.64	12.3	0.64	12.2	0.64	12.3	0.63	-	-		
	1500	5412	2586		2504		2416		2325		2227		2126		2014		1892		1761		1620		-		-	
			16.1	0.58	15.8	0.60	15.4	0.61	15.1	0.62	14.5	0.63	13.9	0.64	13.2	0.67	12.8	0.68	12.7	0.68	12.8	0.68	-	-		
1575	5682	2716		2638		2555		2468		2377		2282		2180		2073		1952		1825		-		-		
		17.4	0.67	17.2	0.69	16.9	0.71	16.6	0.72	16.3	0.73	15.6	0.74	15.0	0.76	14.4	0.78	14.3	0.79	14.3	0.79	-	-			

Performance certified is for installation type A: Free Inlet, Free Outlet. Power rating (BHP) does not include transmission losses. For further information on estimating belt drive losses and motor service factors see page 13. The sound ratings shown are for loudness values in fan sones at 5'0" (1.5m) in a hemispherical free field calculated per AMCA International Standard 301. Values shown are for installation Type A: free inlet hemispherical sone levels. Performance ratings do not include the effects of appurtenances.

# DX12B | BELT DRIVE

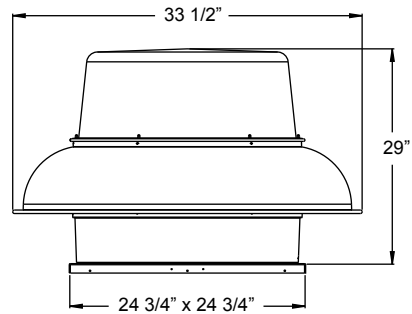
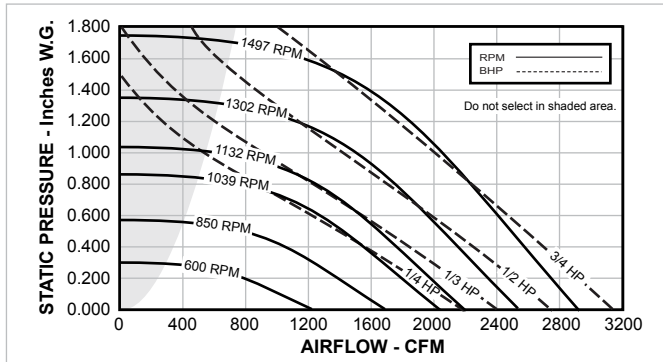

HP	RPM	Tip Speed FPM	0.000" SP		0.125" SP		0.250" SP		0.375" SP		0.500" SP		0.625" SP		0.750" SP		0.875" SP		1.000" SP		1.250" SP			
			CFM		CFM		CFM		CFM		CFM		CFM		CFM		CFM		CFM		CFM			
			Sones	BHP	Sones	BHP	Sones	BHP	Sones	BHP	Sones	BHP	Sones	BHP	Sones	BHP	Sones	BHP	Sones	BHP	Sones	BHP	Sones	BHP
1/4	400	1662	780		-		-		-		-		-		-		-		-		-			
			2.9	0.01	-		-		-		-		-		-		-		-		-			
	500	2078	975		654		-		-		-		-		-		-		-		-			
			4.9	0.02	4.2	0.03	-		-		-		-		-		-		-		-			
	600	2494	1170		922		538		-		-		-		-		-		-		-			
			7.1	0.04	6.6	0.05	6.1	0.05	-		-		-		-		-		-		-			
	700	2909	1365		1151		903		-		-		-		-		-		-		-		-	
			9.4	0.06	8.7	0.07	8.5	0.08	-		-		-		-		-		-		-			
	800	3325	1561		1375		1182		929		-		-		-		-		-		-		-	
			11.0	0.09	10.2	0.11	10.0	0.12	9.6	0.12	-		-		-		-		-		-			
850	3533	1658		1485		1308		1084		769		-		-		-		-		-		-		
		11.5	0.11	10.8	0.13	10.4	0.14	10.2	0.14	9.6	0.12	-		-		-		-		-				
900	3740	1756		1595		1425		1232		985		-		-		-		-		-		-		
		12.2	0.13	11.5	0.15	11.0	0.16	10.8	0.17	10.3	0.17	-		-		-		-		-				
950	3948	1853		1703		1538		1371		1155		858		-		-		-		-		-		
		12.9	0.16	12.3	0.17	11.6	0.18	11.4	0.19	11.0	0.20	10.4	0.19	-		-		-		-				
1000	4156	1951		1811		1650		1499		1308		1076		553		-		-		-		-		
		13.3	0.18	12.8	0.20	12.1	0.21	11.7	0.22	11.4	0.23	11.1	0.23	10.1	0.19	-		-		-				
1039	4318	2027		1894		1737		1597		1422		1219		930		-		-		-		-		
		13.7	0.21	13.2	0.22	12.6	0.24	12.2	0.25	11.7	0.26	11.6	0.26	11.2	0.25	-		-		-				
1/3	1055	4385	2058		1928		1774		1636		1468		1269		1011		-		-		-			
			13.8	0.21	13.4	0.23	12.8	0.25	12.4	0.26	11.9	0.27	11.7	0.28	11.5	0.27	-		-		-			
	1075	4468	2097		1970		1819		1683		1525		1331		1094		524		-		-			
			14.1	0.23	13.6	0.24	13.1	0.26	12.6	0.27	12.2	0.28	12.0	0.29	11.8	0.29	10.8	0.23	-		-			
1100	4572	2146		2023		1875		1740		1591		1408		1197		855		-		-				
		14.5	0.24	13.9	0.26	13.4	0.28	12.9	0.29	12.5	0.30	12.3	0.31	12.2	0.31	11.7	0.29	-		-				
1132	4705	2208		2091		1946		1813		1673		1503		1316		1058		-		-				
		15.0	0.27	14.4	0.28	13.9	0.30	13.4	0.31	13.0	0.33	12.7	0.34	12.6	0.34	12.5	0.33	-		-				
1/2	1150	4779	2244		2128		1986		1854		1719		1556		1373		1136		572		-			
			15.3	0.28	14.7	0.29	14.2	0.31	13.7	0.33	13.3	0.34	12.9	0.35	12.9	0.36	12.9	0.35	12.0	0.28	-			
	1175	4883	2292		2180		2041		1910		1782		1629		1451		1239		906		-			
			15.7	0.30	15.2	0.31	14.6	0.33	14.2	0.35	13.7	0.36	13.3	0.37	13.2	0.38	13.3	0.38	12.9	0.35	-			
	1200	4987	2341		2231		2096		1966		1844		1700		1527		1341		1076		-			
			16.3	0.32	15.8	0.33	15.2	0.35	14.7	0.37	14.3	0.38	13.8	0.39	13.7	0.40	13.7	0.41	13.6	0.39	-			
	1250	5195	2439		2333		2206		2077		1963		1831		1676		1507		1300		-			
			17.2	0.36	16.8	0.37	16.2	0.40	15.7	0.42	15.1	0.43	14.7	0.44	14.4	0.45	14.4	0.46	14.5	0.45	-			
1275	5299	2488		2384		2260		2134		2021		1895		1749		1585		1402		-				
		17.7	0.38	17.2	0.39	16.7	0.42	16.1	0.44	15.5	0.45	14.9	0.47	14.5	0.48	14.6	0.48	14.7	0.48	-				
1302	5411	2540		2439		2319		2195		2082		1963		1827		1668		1503		869				
		18.1	0.40	17.6	0.42	17.1	0.44	16.6	0.46	16.0	0.48	15.4	0.49	14.7	0.51	14.7	0.52	14.9	0.52	14.5	0.45			

# DX12B | BELT DRIVE

HP	RPM	Tip Speed FPM	0.000" SP		0.125" SP		0.250" SP		0.375" SP		0.500" SP		0.625" SP		0.750" SP		0.875" SP		1.000" SP		1.250" SP			
			CFM		CFM		CFM		CFM		CFM		CFM		CFM		CFM		CFM		CFM		CFM	
			Sones	BHP	Sones	BHP	Sones	BHP	Sones	BHP	Sones	BHP	Sones	BHP	Sones	BHP	Sones	BHP	Sones	BHP	Sones	BHP	Sones	BHP
3/4	1325	5507	2585		2486		2369		2247		2134		2021		1891		1736		1576		1106			
			18.5	0.43	18.0	0.44	17.5	0.46	17.0	0.49	16.4	0.50	15.8	0.52	15.2	0.53	14.8	0.54	15.0	0.55	15.1	0.51		
	1350	5611	2634		2536		2423		2303		2190		2083		1956		1810		1654		1248			
			18.9	0.45	18.4	0.47	17.9	0.49	17.4	0.51	16.8	0.53	16.3	0.54	15.7	0.56	15.2	0.57	15.1	0.58	15.6	0.56		
	1400	5818	2731		2637		2530		2414		2302		2201		2084		1955		1807		1463			
			19.9	0.50	19.4	0.52	18.8	0.54	18.3	0.57	17.7	0.59	17.2	0.60	16.7	0.62	16.1	0.63	15.9	0.64	16.2	0.64		
	1425	5922	2780		2688		2584		2469		2357		2258		2147		2026		1882		1566			
			20.0	0.53	19.9	0.55	19.3	0.57	18.7	0.60	18.2	0.62	17.7	0.63	17.2	0.65	16.6	0.66	16.2	0.67	16.3	0.68		
	1450	6026	2829		2738		2637		2524		2413		2315		2210		2092		1955		1663			
			21.0	0.56	20.0	0.58	19.9	0.60	19.3	0.62	18.7	0.65	18.2	0.66	17.6	0.68	17.1	0.69	16.6	0.70	16.6	0.72		
	1497	6222	2921		2833		2737		2627		2520		2421		2327		2212		2091		1811			
			22.0	0.61	21.0	0.63	21.0	0.65	20.0	0.68	19.7	0.71	19.2	0.72	18.7	0.74	18.1	0.75	17.5	0.77	17.3	0.79		

Performance certified is for installation type A: Free Inlet, Free Outlet. Power rating (BHP) does not include transmission losses. For further information on estimating belt drive losses and motor service factors see page 13. The sound ratings shown are for loudness values in fan sones at 5'0" (1.5m) in a hemispherical free field calculated per AMCA International Standard 301. Values shown are for installation Type A: free inlet hemispherical sone levels. Performance ratings do not include the effects of appurtenances.

# DX14B | BELT DRIVE

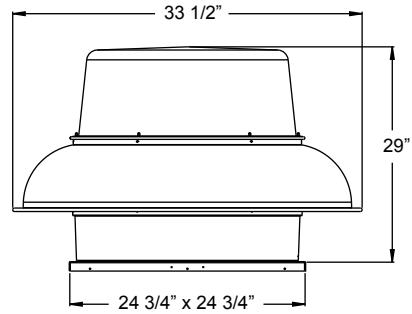
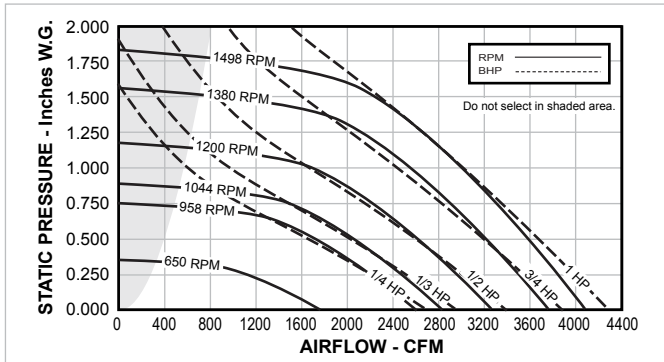

HP	RPM	Tip Speed FPM	0.000" SP		0.125" SP		0.250" SP		0.375" SP		0.500" SP		0.625" SP		0.750" SP		1.000" SP		1.250" SP		1.500" SP	
			CFM		CFM		CFM		CFM		CFM		CFM		CFM		CFM		CFM		CFM	
			Sones	BHP	Sones	BHP	Sones	BHP	Sones	BHP	Sones	BHP	Sones	BHP	Sones	BHP	Sones	BHP	Sones	BHP	Sones	BHP
1/4	350	1455	952		-		-		-		-		-		-		-		-		-	
			1.6	0.01	-		-		-		-		-		-		-		-		-	
	400	1662	1088		221		-		-		-		-		-		-		-		-	
			2.5	0.02	3.0	0.01	-		-		-		-		-		-		-		-	
	515	2140	1401		994		-		-		-		-		-		-		-		-	
			4.8	0.04	4.5	0.04	-		-		-		-		-		-		-		-	
	680	2826	1849		1582		1212		-		-		-		-		-		-		-	
			7.3	0.08	6.7	0.09	6.0	0.09	-		-		-		-		-		-		-	
842	3499	2290		2077		1835		1522		1104		-		-		-		-		-		
		9.7	0.15	9.0	0.17	8.3	0.18	7.4	0.18	6.3	0.17	-		-		-		-		-		
910	3782	2475		2276		2070		1793		1495		831		-		-		-		-		
		10.7	0.19	10.1	0.21	9.5	0.22	8.8	0.23	7.6	0.22	6.9	0.18	-		-		-		-		
958	3982	2606		2415		2226		1977		1699		1355		-		-		-		-		
		11.8	0.23	11.2	0.24	10.6	0.26	10.0	0.26	8.8	0.26	7.6	0.25	-		-		-		-		
1/3	1000	4156	2720		2536		2360		2135		1870		1588		1033		-		-		-	
			12.6	0.26	12.0	0.27	11.4	0.29	10.8	0.30	9.8	0.30	8.5	0.29	7.9	0.25	-		-		-	
	1020	4239	2774		2593		2424		2208		1949		1684		1250		-		-		-	
			12.9	0.27	12.3	0.29	11.8	0.30	11.1	0.32	10.2	0.32	8.9	0.31	8.1	0.29	-		-		-	
1044	4339	2840		2662		2499		2292		2044		1788		1445		-		-		-		
		13.1	0.29	12.6	0.31	12.1	0.33	11.4	0.34	10.7	0.34	9.4	0.34	8.4	0.32	-		-		-		
1/2	1060	4405	2883		2708		2549		2348		2106		1854		1561		-		-		-	
			13.4	0.31	12.8	0.32	12.4	0.34	11.7	0.35	11.0	0.36	9.8	0.35	8.7	0.34	-		-		-	
	1095	4551	2978		2809		2654		2469		2240		1998		1738		-		-		-	
			14.2	0.34	13.7	0.35	13.2	0.37	12.6	0.39	11.9	0.39	10.7	0.39	9.5	0.38	-		-		-	
	1130	4696	3074		2909		2758		2586		2373		2138		1901		610		-		-	
			15.2	0.37	14.6	0.39	14.1	0.41	13.6	0.42	12.8	0.43	11.9	0.43	10.5	0.43	9.3	0.25	-		-	
	1160	4821	3155		2995		2847		2683		2484		2257		2027		1251		-		-	
			16.0	0.40	15.5	0.42	15.1	0.44	14.5	0.46	13.8	0.47	12.9	0.47	11.5	0.46	9.8	0.40	-		-	
1190	4946	3237		3081		2936		2780		2592		2373		2150		1556		-		-		
		17.0	0.44	16.4	0.45	16.0	0.47	15.5	0.49	14.8	0.50	14.0	0.51	12.6	0.50	10.4	0.47	-		-		
1200	4987	3264		3109		2965		2812		2627		2412		2191		1629		-		-		
		17.3	0.45	16.8	0.46	16.3	0.48	15.8	0.50	15.1	0.52	14.4	0.52	12.9	0.52	10.6	0.49	-		-		

# DX14B | BELT DRIVE

HP	RPM	Tip Speed FPM	0.000" SP		0.125" SP		0.250" SP		0.375" SP		0.500" SP		0.625" SP		0.750" SP		1.000" SP		1.250" SP		1.500" SP			
			CFM		CFM		CFM		CFM		CFM		CFM		CFM		CFM		CFM		CFM		CFM	
			Sones	BHP	Sones	BHP	Sones	BHP	Sones	BHP	Sones	BHP	Sones	BHP	Sones	BHP	Sones	BHP	Sones	BHP	Sones	BHP	Sones	BHP
3/4	1218	5062	3313		3160		3018		2869		2690		2481		2263		1759		-		-			
			17.7	0.47	17.2	0.48	16.7	0.50	16.2	0.52	15.6	0.54	14.8	0.54	13.5	0.54	11.0	0.52	-	-	-	-		
	1285	5341	3495		3351		3213		3081		2921		2733		2528		2105		1072		-			
			18.5	0.55	18.0	0.56	17.5	0.58	17.1	0.61	16.5	0.63	15.8	0.64	15.1	0.40	12.6	0.62	11.8	0.47	-	-		
	1315	5465	3577		3435		3300		3173		3019		2844		2644		2238		1594		-			
			18.7	0.59	18.2	0.60	17.7	0.62	17.3	0.65	16.8	0.67	16.2	0.68	15.5	0.68	13.3	0.67	12.2	0.62	-	-		
1345	5590	3659		3520		3387		3262		3116		2949		2759		2363		1845		-				
		19.0	0.63	18.5	0.65	18.1	0.67	17.7	0.69	17.2	0.71	16.6	0.73	16.0	0.73	14.0	0.72	12.5	0.69	-	-			
1380	5735	3754		3619		3488		3367		3229		3071		2891		2507		2080		699				
		19.5	0.68	19.1	0.70	18.6	0.72	18.2	0.74	17.8	0.76	17.2	0.78	16.6	0.79	14.9	0.79	13.1	0.76	12.9	0.45			
1	1400	5818	3808		3675		3546		3426		3293		3140		2966		2587		2178		939			
			19.9	0.71	19.4	0.73	19.0	0.75	18.6	0.77	18.2	0.79	17.6	0.81	17.0	0.82	15.5	0.82	13.6	0.80	13.2	0.53		
	1425	5922	3876		3746		3617		3500		3372		3226		3059		2687		2298		1579			
			20.0	0.75	20.0	0.77	19.5	0.79	19.2	0.81	18.8	0.83	18.2	0.86	17.6	0.87	16.2	0.87	14.3	0.85	13.6	0.76		
	1450	6026	3944		3816		3689		3574		3451		3309		3149		2786		2417		1848			
			21.0	0.79	21.0	0.81	20.0	0.83	19.7	0.85	19.3	0.87	18.8	0.90	18.2	0.91	16.8	0.91	15.0	0.90	14.0	0.85		
1475	6130	4012		3886		3761		3647		3530		3391		3236		2885		2523		2033				
		22.0	0.83	21.0	0.85	21.0	0.87	20.0	0.89	19.8	0.92	19.3	0.94	18.8	0.96	17.5	0.96	15.7	0.95	14.2	0.91			
1498	6226	4075		3951		3826		3714		3602		3465		3317		2974		2618		2200				
		22.0	0.87	22.0	0.89	21.0	0.91	21.0	0.93	20.0	0.96	19.8	0.98	19.3	1.00	18.1	1.01	16.3	1.00	14.6	0.97			

Performance certified is for installation type A: Free Inlet, Free Outlet. Power rating (BHP) does not include transmission losses. For further information on estimating belt drive losses and motor service factors see page 13. The sound ratings shown are for loudness values in fan sones at 5'0" (1.5m) in a hemispherical free field calculated per AMCA International Standard 301. Values shown are for installation Type A: free inlet hemispherical sone levels. Performance ratings do not include the effects of appurtenances.



# DX16B | BELT DRIVE

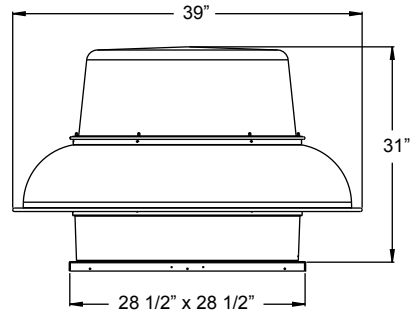
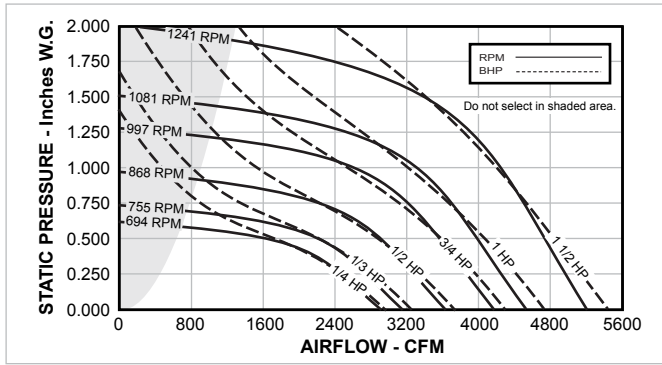

HP	RPM	Tip Speed FPM	0.000" SP		0.125" SP		0.250" SP		0.375" SP		0.500" SP		0.625" SP		0.750" SP		1.000" SP		1.250" SP		1.500" SP	
			CFM		CFM		CFM		CFM		CFM		CFM		CFM		CFM		CFM		CFM	
			Sones	BHP	Sones	BHP	Sones	BHP	Sones	BHP	Sones	BHP	Sones	BHP	Sones	BHP	Sones	BHP	Sones	BHP	Sones	BHP
1/4	300	1473	1149		-		-		-		-		-		-		-		-		-	
			3.1	0.019	-		-		-		-		-		-		-		-		-	
	450	2209	1723		1453		-		-		-		-		-		-		-		-	
			5.2	0.064	4.5	0.075	-		-		-		-		-		-		-		-	
	600	2945	2298		2105		1880		1323		-		-		-		-		-		-	
			8.8	0.152	8.3	0.168	7.9	0.179	7.4	0.168	-		-		-		-		-		-	
650	3191	2489		2314		2119		1811		711		-		-		-		-		-		
		9.7	0.193	9.1	0.211	8.8	0.224	8.5	0.230	7.8	0.150	-		-		-		-		-		
694	3407	2658		2493		2315		2102		1542		-		-		-		-		-		
		10.4	0.235	10	0.254	9.7	0.269	9.3	0.280	8.8	0.260	-		-		-		-		-		
1/3	715	3510	2738		2579		2407		2205		1785		-		-		-		-		-	
			10.9	0.257	10.5	0.276	10.1	0.292	9.8	0.305	9.2	0.297	-		-		-		-		-	
	735	3608	2815		2660		2494		2303		1968		1027		-		-		-		-	
			11.5	0.279	11	0.299	10.6	0.316	10.2	0.329	9.7	0.329	9.2	0.244	-		-		-		-	
	755	3706	2891		2740		2580		2399		2123		1382		-		-		-		-	
11.9			0.303	11.6	0.323	11.1	0.341	10.7	0.355	10.3	0.360	9.7	0.305	-		-		-		-		
775	3804	2968		2821		2666		2495		2263		1713		-		-		-		-		
		12.3	0.328	11.9	0.348	11.6	0.367	11.2	0.382	10.7	0.390	10.1	0.361	-		-		-		-		
1/2	800	3927	3063		2921		2772		2613		2421		2001		985		-		-		-	
			12.8	0.360	12.4	0.382	12.0	0.401	11.7	0.418	11.3	0.430	10.6	0.417	10.3	0.295	-		-		-	
	825	4050	3159		3021		2878		2726		2544		2230		1482		-		-		-	
			13.3	0.395	12.9	0.417	12.5	0.438	12.2	0.455	11.8	0.468	11.2	0.467	10.7	0.394	-		-		-	
	850	4172	3255		3121		2983		2836		2665		2415		1889		-		-		-	
			13.8	0.432	13.5	0.455	13.1	0.477	12.7	0.495	12.3	0.509	11.9	0.514	11.2	0.478	-		-		-	
868	4261	3324		3193		3059		2914		2752		2541		2106		-		-		-		
		14.3	0.460	13.9	0.483	13.5	0.506	13.2	0.524	12.8	0.540	12.3	0.549	11.6	0.527	-		-		-		
895	4393	3427		3300		3172		3032		2881		2709		2363		-		-		-		
		15.0	0.505	14.6	0.528	14.2	0.552	13.9	0.571	13.5	0.588	13.0	0.601	12.4	0.592	-		-		-		
3/4	925	4541	3542		3419		3296		3161		3023		2857		2602		1174		-		-	
			15.8	0.557	15.4	0.582	15.0	0.606	14.7	0.626	14.3	0.646	13.9	0.659	13.3	0.662	12.5	0.463	-		-	
	950	4663	3638		3518		3398		3268		3136		2978		2778		1671		-		-	
			16.5	0.603	16.1	0.629	15.8	0.654	15.4	0.675	15.0	0.696	15.0	0.710	14.2	0.719	13.1	0.594	-		-	
	975	4786	3734		3617		3500		3375		3246		3099		2941		2086		-		-	
			17.1	0.652	16.7	0.678	16.4	0.704	16.0	0.727	15.7	0.747	15.3	0.764	14.8	0.778	13.6	0.709	-		-	
997	4894	3818		3704		3589		3468		3342		3204		3050		2368		-		-		
		17.4	0.697	17.1	0.724	16.7	0.751	16.4	0.774	16.0	0.795	15.7	0.814	15.2	0.828	13.9	0.791	-		-		
1025	5031	3925		3814		3703		3586		3464		3337		3187		2652		1018		-		
		17.9	0.758	17.6	0.785	17.2	0.813	16.9	0.838	16.5	0.859	16.2	0.880	15.8	0.895	14.6	0.885	14.1	0.561	-		

# DX16B | BELT DRIVE

HP	RPM	Tip Speed FPM	0.000" SP		0.125" SP		0.250" SP		0.375" SP		0.500" SP		0.625" SP		0.750" SP		1.000" SP		1.250" SP		1.500" SP			
			CFM		CFM		CFM		CFM		CFM		CFM		CFM		CFM		CFM		CFM		CFM	
			Sones	BHP	Sones	BHP	Sones	BHP	Sones	BHP	Sones	BHP	Sones	BHP	Sones	BHP	Sones	BHP	Sones	BHP	Sones	BHP	Sones	BHP
1	1055	5179	4040		3932		3824		3713		3594		3475		3332		2912		1759		-			
			18.5	0.826	18.1	0.855	17.8	0.883	17.4	0.909	17.1	0.932	16.7	0.954	16.3	0.970	15.4	0.981	14.4	0.790	-			
	1081	5306	4140		4034		3929		3822		3705		3589		3457		3096		2172		-			
			18.9	0.889	18.6	0.918	18.3	0.947	17.9	0.975	17.6	0.998	17.2	1.021	16.8	1.039	15.9	1.058	14.7	0.939	-			
	1115	5473	4270		4168		4065		3963		3851		3738		3618		3332		2652		834			
			19.8	0.976	19.4	1.005	19.1	1.035	18.7	1.065	18.4	1.089	18.1	1.112	17.6	1.134	16.7	1.165	15.3	1.107	15.1	0.635		
1 1/2	1150	5645	4404		4305		4206		4107		3999		3890		3781		3515		3001		1822			
			21.0	1.070	20.0	1.101	20.0	1.132	19.7	1.163	19.3	1.188	19.0	1.213	18.6	1.237	17.7	1.271	16.5	1.253	15.6	0.996		
	1180	5792	4519		4422		4326		4229		4126		4020		3913		3662		3259		2306			
			22.0	1.156	21.0	1.188	21.0	1.219	21.0	1.251	20.0	1.278	19.8	1.304	19.4	1.329	18.6	1.366	17.5	1.373	16.2	1.207		
	1210	5940	4634		4539		4445		4351		4253		4149		4045		3808		3471		2767			
			22.0	1.247	22.0	1.279	22.0	1.311	21.0	1.344	21.0	1.373	21.0	1.399	20.0	1.425	19.3	1.466	18.4	1.484	16.8	1.394		
	1241	6092	4752		4660		4569		4477		4383		4281		4180		3957		3687		3115			
			23.0	1.345	23.0	1.378	22.0	1.411	22.0	1.445	22.0	1.476	21.0	1.502	21.0	1.529	20.0	1.574	19.1	1.605	17.8	1.556		

Performance certified is for installation type A: Free Inlet, Free Outlet. Power rating (BHP) does not include transmission losses. For further information on estimating belt drive losses and motor service factors see page 13. The sound ratings shown are for loudness values in fan sones at 5'0" (1.5m) in a hemispherical free field calculated per AMCA International Standard 301. Values shown are for installation Type A: free inlet hemispherical sone levels. Performance ratings do not include the effects of appurtenances.

# DX18B | BELT DRIVE

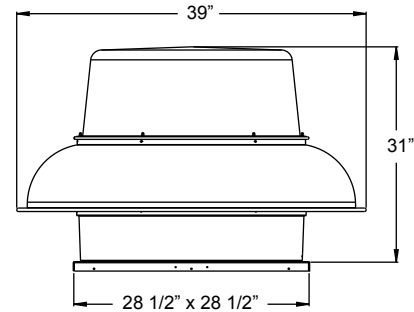
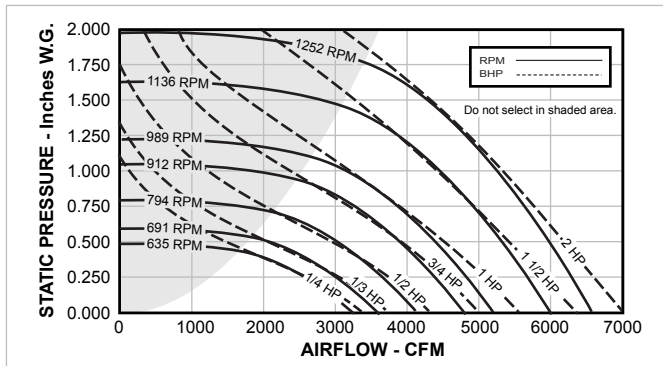

HP	RPM	Tip Speed FPM	0.000" SP		0.125" SP		0.250" SP		0.375" SP		0.500" SP		0.625" SP		0.750" SP		1.000" SP		1.250" SP		1.500" SP			
			CFM		CFM		CFM		CFM		CFM		CFM		CFM		CFM		CFM		CFM		CFM	
			Sones	BHP	Sones	BHP	Sones	BHP	Sones	BHP	Sones	BHP	Sones	BHP	Sones	BHP	Sones	BHP	Sones	BHP	Sones	BHP	Sones	BHP
1/4	375	1988	1975		1402		-		-		-		-		-		-		-		-		-	
			3.9	0.04	3.6	0.05	-		-		-		-		-		-		-		-		-	
	549	2910	2892		2531		2138		-		-		-		-		-		-		-		-	
			8.0	0.14	7.7	0.16	7.1	0.17	-		-		-		-		-		-		-		-	
	590	3128	3108		2774		2417		1746		-		-		-		-		-		-		-	
8.9			0.18	8.5	0.20	7.9	0.21	7.4	0.20	-		-		-		-		-		-		-		
635	3366	3345		3037		2711		2291		-		-		-		-		-		-		-		
		10.1	0.22	9.7	0.24	9.1	0.26	8.3	0.26	-		-		-		-		-		-		-		
1/3	655	3472	3450		3153		2838		2478		1493		-		-		-		-		-		-	
			10.4	0.24	10.0	0.26	9.4	0.28	8.7	0.29	8.2	0.24	-		-		-		-		-		-	
	675	3578	3555		3268		2963		2638		1913		-		-		-		-		-		-	
10.7			0.26	10.3	0.29	9.8	0.31	9.1	0.32	8.4	0.30	-		-		-		-		-		-		
691	3663	3640		3360		3062		2751		2162		-		-		-		-		-		-		
		10.9	0.28	10.5	0.31	10.1	0.33	9.3	0.34	8.5	0.34	-		-		-		-		-		-		
1/2	715	3791	3766		3497		3209		2911		2456		-		-		-		-		-		-	
			11.4	0.31	11.0	0.34	10.5	0.36	9.8	0.38	9.0	0.37	-		-		-		-		-		-	
	740	3923	3898		3639		3361		3075		2712		1852		-		-		-		-		-	
			12.1	0.35	11.7	0.37	11.2	0.39	10.4	0.41	9.7	0.42	9.1	0.37	-		-		-		-		-	
770	4082	4056		3808		3542		3271		2974		2383		-		-		-		-		-		
		13.1	0.39	12.7	0.42	12.2	0.44	11.5	0.46	10.6	0.48	9.7	0.46	-		-		-		-		-		
794	4209	4182		3943		3685		3424		3150		2684		1604		-		-		-		-		
		14.2	0.43	13.7	0.46	13.2	0.48	12.5	0.50	11.6	0.52	10.6	0.51	10.3	0.41	-		-		-		-		
3/4	825	4374	4345		4115		3868		3618		3357		3010		2313		-		-		-		-	
			15.2	0.48	14.8	0.51	14.2	0.53	13.7	0.56	12.6	0.58	11.6	0.58	10.8	0.54	-		-		-		-	
	855	4533	4503		4281		4045		3804		3555		3278		2763		-		-		-		-	
			15.5	0.53	15.1	0.57	14.6	0.59	14.1	0.62	13.2	0.64	12.2	0.65	11.2	0.64	-		-		-		-	
885	4692	4662		4447		4220		3987		3750		3504		3107		-		-		-		-		
		16.3	0.59	15.9	0.63	15.4	0.65	14.9	0.68	14.1	0.70	13.3	0.72	12.3	0.71	-		-		-		-		
912	4835	4804		4595		4376		4151		3923		3684		3376		1675		-		-		-		
		17.1	0.65	16.8	0.68	16.3	0.71	15.8	0.74	15.1	0.76	14.3	0.78	13.4	0.78	12.3	0.59	-		-		-		
1	930	4930	4899		4694		4480		4259		4036		3803		3536		2206		-		-		-	
			17.8	0.69	17.4	0.72	17.0	0.75	16.5	0.78	15.9	0.81	15.0	0.83	14.1	0.84	12.8	0.72	-		-		-	
	965	5116	5083		4886		4682		4469		4255		4034		3806		2875		-		-		-	
			18.9	0.77	18.7	0.81	18.3	0.84	17.8	0.86	17.3	0.89	16.5	0.92	15.7	0.94	13.8	0.90	-		-		-	
989	5243	5209		5017		4819		4612		4403		4190		3969		3213		-		-		-		
		19.9	0.82	19.6	0.87	19.2	0.90	18.7	0.92	18.2	0.95	17.5	0.98	16.7	1.00	14.9	0.99	-		-		-		

# DX18B | BELT DRIVE

HP	RPM	Tip Speed FPM	0.000" SP		0.125" SP		0.250" SP		0.375" SP		0.500" SP		0.625" SP		0.750" SP		1.000" SP		1.250" SP		1.500" SP			
			CFM		CFM		CFM		CFM		CFM		CFM		CFM		CFM		CFM		CFM		CFM	
			Sones	BHP	Sones	BHP	Sones	BHP	Sones	BHP	Sones	BHP	Sones	BHP	Sones	BHP	Sones	BHP	Sones	BHP	Sones	BHP	Sones	BHP
1 1/2	1030	5460	5425		5241		5053		4853		4653		4451		4240		3671		2215		-			
			21.0	0.93	21.0	0.97	20.0	1.01	19.9	1.04	19.5	1.07	18.9	1.10	18.0	1.12	16.5	1.12	15.5	0.92	-			
	1065	5646	5610		5431		5251		5058		4865		4671		4470		4006		2984		-			
			22.0	1.03	21.0	1.07	21.0	1.12	21.0	1.14	20.0	1.17	19.5	1.20	18.7	1.23	17.3	1.25	15.9	1.17	-			
	1100	5832	5794		5621		5448		5262		5075		4887		4697		4291		3517		-			
22.0			1.13	22.0	1.18	22.0	1.23	21.0	1.25	21.0	1.28	20.0	1.31	19.5	1.34	18.1	1.39	16.5	1.36	-				
1136	6022	5984		5816		5649		5470		5289		5108		4925		4543		3945		2625				
		23.0	1.25	23.0	1.30	22.0	1.34	22.0	1.34	22.0	1.37	21.0	1.44	21.0	1.47	19.2	1.52	17.7	1.49	16.8	1.29			
2	1175	6229	6189		6027		5865		5694		5520		5345		5169		4802		4336		3414			
			24.0	1.38	24.0	1.43	24.0	1.48	23.0	1.51	23.0	1.54	22.0	1.57	22.0	1.61	20.0	1.67	19.1	1.67	17.6	1.60		
	1200	6362	6321		6162		6004		5838		5667		5495		5323		4967		4560		3786			
			25.0	1.47	25.0	1.52	24.0	1.57	24.0	1.61	23.0	1.64	23.0	1.67	23.0	1.71	21.0	1.77	20.0	1.80	18.3	1.77		
	1225	6494	6453		6297		6142		5980		5813		5645		5477		5153		4763		4100			
25.0			1.57	25.0	1.62	25.0	1.67	25.0	1.71	24.0	1.74	24.0	1.77	23.0	1.81	22.0	1.87	21.0	1.93	19.6	1.88			
1252	6637	6595		6443		6291		6134		5970		5806		5641		5307		4958		4399				
			26.0	1.67	26.0	1.73	26.0	1.78	26.0	1.82	25.0	1.85	25.0	1.88	24.0	1.92	23.0	1.99	22.0	2.05	21.0	2.00		

Performance certified is for installation type A: Free Inlet, Free Outlet. Power rating (BHP) does not include transmission losses. For further information on estimating belt drive losses and motor service factors see page 13. The sound ratings shown are for loudness values in fan sonos at 5'0" (1.5m) in a hemispherical free field calculated per AMCA International Standard 301. Values shown are for installation Type A: free inlet hemispherical sone levels. Performance ratings do not include the effects of appurtenances.

# DX24B | BELT DRIVE

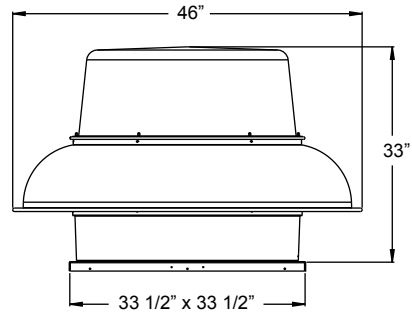
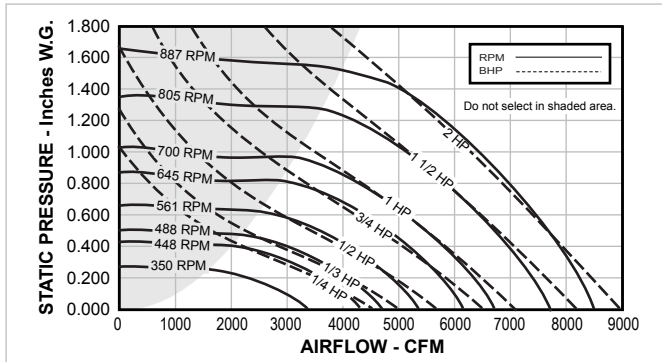

HP	RPM	Tip Speed FPM	0.000" SP		0.125" SP		0.250" SP		0.375" SP		0.500" SP		0.625" SP		0.750" SP		1.000" SP		1.250" SP		1.500" SP	
			CFM		CFM		CFM		CFM		CFM		CFM		CFM		CFM		CFM		CFM	
			Sones	BHP	Sones	BHP	Sones	BHP	Sones	BHP	Sones	BHP	Sones	BHP	Sones	BHP	Sones	BHP	Sones	BHP	Sones	BHP
1/4	265	1719	2547		1450		-		-		-		-		-		-		-		-	
			3.1	0.05	1.4	0.05	-		-		-		-		-		-		-		-	
	399	2589	3835		3315		2531		-		-		-		-		-		-		-	
			7.6	0.15	7.0	0.18	5.5	0.18	-		-		-		-		-		-			
			4133		3675		2998		-		-		-		-		-		-		-	
430	2790	8.2	0.19	7.6	0.22	6.9	0.23	-		-		-		-		-		-		-		
		4306		3873		3251		2278		-		-		-		-		-		-		
1/3	460	2984	4421		4003		3407		2534		-		-		-		-		-		-	
			8.9	0.24	8.2	0.27	7.6	0.28	5.2	0.27	-		-		-		-		-			
	475	3082	4565		4164		3600		2837		-		-		-		-		-		-	
			9.3	0.26	8.7	0.29	8.0	0.31	6.1	0.30	-		-		-		-		-			
488	3166	4690		4303		3766		3087		-		-		-		-		-		-		
		9.7	0.28	9.1	0.32	8.4	0.34	6.9	0.33	-		-		-		-		-				
1/2	520	3374	4998		4643		4163		3575		2688		-		-		-		-		-	
			10.6	0.34	10.0	0.38	9.3	0.40	8.4	0.41	5.9	0.38	-		-		-		-			
	530	3438	5094		4749		4283		3721		2901		-		-		-		-		-	
			10.8	0.36	10.2	0.40	9.5	0.42	8.8	0.43	6.5	0.41	-		-		-		-			
	540	3503	5190		4854		4402		3865		3107		-		-		-		-		-	
11.0			0.38	10.5	0.42	9.7	0.45	9.0	0.46	7.0	0.43	-		-		-		-				
561	3640	5392		5075		4650		4142		3517		-		-		-		-		-		
3/4	600	3893	5767		5473		5104		4642		4122		3399		-		-		-		-	
			13.1	0.52	12.6	0.57	11.9	0.59	11.2	0.62	10.3	0.62	8.2	0.59	-		-		-			
	625	4055	6007		5726		5384		4955		4484		3890		2988		-		-		-	
			14.3	0.59	13.7	0.64	13.0	0.67	12.3	0.70	11.6	0.71	9.9	0.69	8.2	0.64	-		-			
645	4185	6200		5926		5601		5196		4747		4226		3466		-		-		-		
1	663	4301	6373		6107		5795		5411		4980		4493		3838		-		-		-	
			14.7	0.71	14.2	0.76	13.7	0.79	13.0	0.82	12.3	0.85	11.4	0.84	9.7	0.80	-		-			
	675	4379	6488		6227		5924		5553		5134		4669		4075		-		-		-	
			15.0	0.75	14.5	0.80	13.9	0.84	13.1	0.86	12.6	0.89	11.8	0.89	10.3	0.86	-		-			
	685	4444	6584		6327		6031		5671		5261		4815		4268		-		-		-	
15.2			0.78	14.7	0.84	14.1	0.87	13.5	0.90	12.8	0.93	12.1	0.93	10.8	0.90	-		-				
700	4541	6728		6477		6191		5847		5450		5031		4531		-		-		-		
			15.5	0.83	15.0	0.89	14.5	0.93	13.9	0.96	13.3	0.99	12.6	1.00	11.5	0.97	-		-			

# DX24B | BELT DRIVE

HP	RPM	Tip Speed FPM	0.000" SP		0.125" SP		0.250" SP		0.375" SP		0.500" SP		0.625" SP		0.750" SP		1.000" SP		1.250" SP		1.500" SP			
			CFM		CFM		CFM		CFM		CFM		CFM		CFM		CFM		CFM		CFM		CFM	
			Sones	BHP	Sones	BHP	Sones	BHP	Sones	BHP	Sones	BHP	Sones	BHP	Sones	BHP	Sones	BHP	Sones	BHP	Sones	BHP	Sones	BHP
1 1/2	750	4866	7209		6974		6721		6425		6063		5680		5269		4113		-		-			
			17.0	1.02	16.6	1.09	16.1	1.14	15.5	1.16	14.9	1.20	14.3	1.22	13.7	1.22	11.1	1.15	-	-	-	-		
	775	5028	7449		7222		6984		6697		6360		5998		5619		4619		-		-			
			17.9	1.13	17.5	1.19	17.1	1.25	16.5	1.27	16.0	1.31	15.4	1.34	14.8	1.36	12.4	1.30	-	-	-	-		
	790	5125	7593		7370		7141		6860		6537		6186		5815		4910		-		-			
18.6			1.20	18.2	1.26	17.7	1.32	17.2	1.34	16.6	1.38	16.0	1.42	15.5	1.43	13.4	1.39	-	-	-	-			
805	5223	7738		7519		7298		7022		6713		6374		6009		5182		3788		-				
		19.1	1.27	18.6	1.33	18.1	1.40	17.6	1.42	17.0	1.45	16.5	1.50	15.9	1.51	14.1	1.48	12.0	1.35	-	-			
2	820	5320	7882		7667		7452		7183		6888		6556		6202		5407		4203		-			
			19.2	1.34	18.8	1.41	18.3	1.48	17.8	1.50	17.3	1.53	16.7	1.58	16.1	1.60	14.6	1.57	12.3	1.48	-	-		
	850	5515	8170		7963		7756		7505		7235		6915		6583		5851		4836		-			
			19.6	1.49	19.2	1.56	18.8	1.63	18.3	1.66	17.8	1.69	17.2	1.74	16.7	1.77	15.5	1.77	13.5	1.69	-	-		
	870	5644	8362		8160		7957		7718		7462		7152		6834		6142		5234		-			
20.0			1.60	20.0	1.67	19.5	1.74	19.0	1.78	18.5	1.80	17.9	1.85	17.4	1.89	16.3	1.91	14.3	1.84	-	-			
887	5755	8526		8327		8129		7898		7648		7352		7046		6384		5561		4317				
		21.0	1.69	21.0	1.77	20.0	1.84	19.7	1.89	19.2	1.91	18.6	1.95	18.1	2.00	17.0	2.04	15.3	1.97	13.9	1.83			

Performance certified is for installation type A: Free Inlet, Free Outlet. Power rating (BHP) does not include transmission losses. For further information on estimating belt drive losses and motor service factors see page 13. The sound ratings shown are for loudness values in fan sones at 5'0" (1.5m) in a hemispherical free field calculated per AMCA International Standard 301. Values shown are for installation Type A: free inlet hemispherical sone levels. Performance ratings do not include the effects of appurtenances.

# DX27B | BELT DRIVE

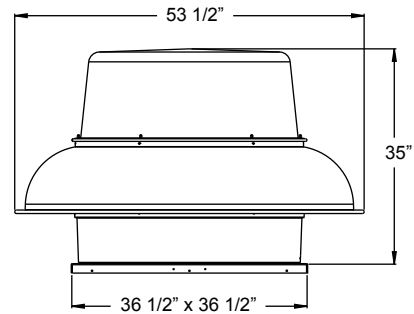
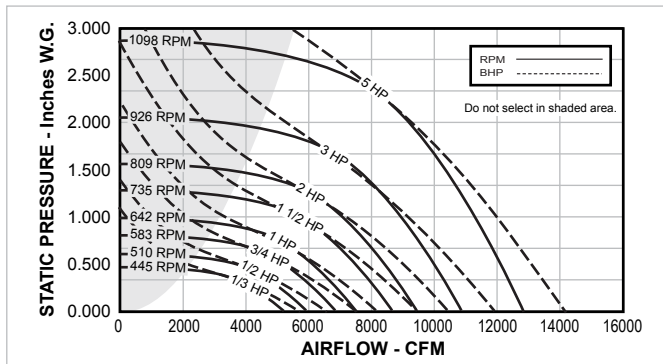

HP	RPM	Tip Speed FPM	0.125" SP		0.250" SP		0.375" SP		0.500" SP		0.750" SP		1.000" SP		1.250" SP		1.500" SP		2.000" SP	
			CFM		CFM		CFM		CFM		CFM		CFM		CFM		CFM		CFM	
			Sones	BHP	Sones	BHP	Sones	BHP	Sones	BHP	Sones	BHP	Sones	BHP	Sones	BHP	Sones	BHP	Sones	BHP
1/3	445	3234	4748		4165		3314		-		-		-		-		-		-	
			8.1	0.29	7.3	0.32	6.8	0.33	-		-		-		-		-		-	
1/2	475	3451	5124		4604		3947		-		-		-		-		-		-	
			9.2	0.34	8.4	0.38	7.7	0.40	-		-		-		-		-		-	
	510	3703	5557		5102		4545		3731		-		-		-		-		-	
			10.3	0.42	9.5	0.46	8.8	0.46	8.4	0.50	-		-		-		-		-	
3/4	530	3850	5808		5386		4866		4180		-		-		-		-		-	
			10.9	0.47	10.2	0.51	9.5	0.54	9.0	0.56	-		-		-		-		-	
	560	4068	6178		5801		5321		4773		-		-		-		-		-	
			12.1	0.55	11.4	0.59	10.6	0.63	10.0	0.66	-		-		-		-		-	
	583	4239	6466		6121		5664		5166		-		-		-		-		-	
			13.3	0.62	12.5	0.66	11.6	0.70	10.9	0.73	-		-		-		-		-	
1	600	4359	6670		6345		5915		5430		3890		-		-		-		-	
			13.8	0.67	13.1	0.71	12.2	0.76	11.4	0.79	10.8	0.79	-		-		-		-	
	620	4504	6912		6593		6188		5744		4473		-		-		-		-	
			14.4	0.73	13.9	0.78	13.0	0.83	12.1	0.87	11.3	0.90	-		-		-		-	
	642	4666	7182		6875		6501		6079		4967		-		-		-		-	
			15.0	0.81	14.5	0.86	13.8	0.91	12.9	0.95	11.9	1.00	-		-		-		-	
1 1/2	660	4795	7398		7099		6748		6340		5356		-		-		-		-	
			15.4	0.87	15.0	0.93	14.3	0.98	13.5	1.02	12.4	1.09	-		-		-		-	
	685	4976	7701		7412		7093		6702		5830		4186		-		-		-	
			16.2	0.97	15.9	1.03	15.3	1.08	14.5	1.13	13.1	1.20	13.1	1.15	-		-		-	
	710	5158	8003		7724		7434		7061		6253		5029		-		-		-	
			17.2	1.08	16.9	1.14	16.4	1.19	15.7	1.24	14.2	1.33	13.7	1.21	-		-		-	
	735	5341	8306		8036		7775		7417		6654		5594		-		-		-	
			18.3	1.19	18.1	1.25	17.7	1.31	17.0	1.37	15.6	1.46	14.7	1.50	-		-		-	
2	750	5449	8484		8220		7975		7624		6888		5921		-		-		-	
			18.9	1.26	18.7	1.33	18.4	1.38	17.7	1.44	16.3	1.54	15.2	1.64	-		-		-	
	770	5594	8724		8467		8210		7901		7201		6339		4824		-		-	
			19.7	1.36	19.5	1.43	19.0	1.49	18.5	1.55	17.2	1.65	15.9	1.72	15.8	1.65	-		-	
	790	5739	8964		8713		8463		8177		7497		6714		5514		-		-	
			20.0	1.47	20.0	1.54	19.9	1.60	19.4	1.66	18.0	1.77	16.7	1.85	16.3	1.99	-		-	
	809	5877	9192		8947		8702		8437		7775		7046		5967		-		-	
			21.0	1.57	21.0	1.64	20.0	1.71	20.0	1.77	18.7	1.88	17.4	1.97	16.9	1.99	-		-	

# DX27B | BELT DRIVE

HP	RPM	Tip Speed FPM	0.125" SP		0.250" SP		0.375" SP		0.500" SP		0.750" SP		1.000" SP		1.250" SP		1.500" SP		2.000" SP	
			CFM		CFM		CFM		CFM		CFM		CFM		CFM		CFM		CFM	
			Sones	BHP	Sones	BHP	Sones	BHP	Sones	BHP	Sones	BHP	Sones	BHP	Sones	BHP	Sones	BHP	Sones	BHP
3	840	6102	9562		9326		9091		8856		8224		7543		6652		5163		-	
			22.0	1.75	22.0	1.83	22.0	1.90	21.0	1.96	20.0	2.08	18.9	2.18	17.9	2.24	18.1	2.13	-	
	870	6320	9920		9692		9465		9238		8654		8016		7259		6171		-	
			24.0	1.94	23.0	2.02	23.0	2.09	23.0	2.16	22.0	2.29	21.0	2.40	19.0	2.47	19.0	2.49	-	
	900	6538	10278		10057		9838		9618		9078		8476		7805		6843		-	
			25.0	2.15	25.0	2.23	25.0	2.30	24.0	2.37	24.0	2.51	22.0	2.63	21.0	2.72	20.0	2.75	-	
	926	6727	10587		10373		10159		9946		9441		8858		8224		7414		-	
			27.0	2.33	27.0	2.42	26.0	2.49	26.0	2.56	25.0	2.71	24.0	2.84	23.0	2.93	21.0	2.99	-	
5	960	6974	10992		10785		10579		10373		9910		9353		8763		8082		5611	
			29.0	2.59	29.0	2.68	28.0	2.76	28.0	2.84	27.0	2.98	26.0	3.12	25.0	3.24	23.0	3.27	23.0	3.14
	1000	7265	11467		11268		11078		10872		10458		9927		9385		8778		7000	
			31.0	2.92	30.0	3.02	30.0	3.10	30.0	3.18	29.0	3.33	28.0	3.48	27.0	3.62	25.0	3.71	24.0	3.75
	1040	7555	11941		11750		11559		11369		10889		10493		9973		9416		7919	
			32.0	3.28	31.0	3.38	31.0	3.47	31.0	3.55	30.0	3.71	29.0	3.87	28.0	4.01	27.0	4.13	25.0	4.24
	1098	7977	12627		12447		12266		12086		11726		11299		10812		10318		9135	
			34.0	3.84	34.0	3.95	34.0	4.05	33.0	4.14	33.0	4.61	32.0	4.48	31.0	4.63	30.0	4.78	27.0	4.98

Performance certified is for installation type A: Free Inlet, Free Outlet. Power rating (BHP) does not include transmission losses. For further information on estimating belt drive losses and motor service factors see page 13. The sound ratings shown are for loudness values in fan sones at 5'0" (1.5m) in a hemispherical free field calculated per AMCA International Standard 301. Values shown are for installation Type A: free inlet hemispherical sone levels. Performance ratings do not include the effects of appurtenances.



# DX30B | BELT DRIVE

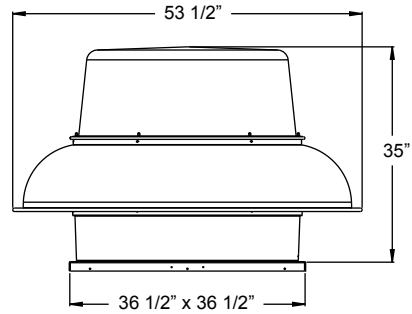
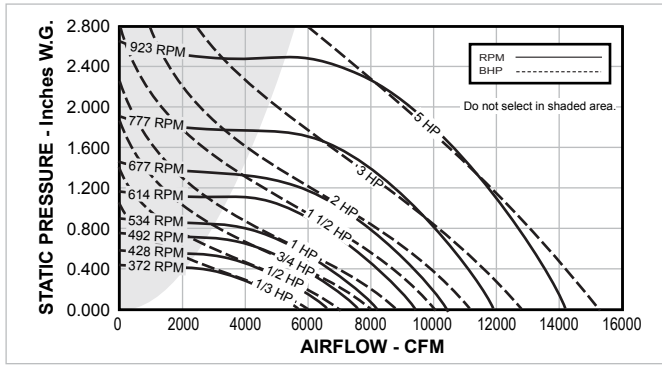

HP	RPM	Tip Speed FPM	0.000" SP		0.125" SP		0.250" SP		0.375" SP		0.500" SP		0.625" SP		0.750" SP		1.000" SP		1.250" SP		1.500" SP							
			CFM		CFM		CFM		CFM		CFM		CFM		CFM		CFM		CFM		CFM		CFM					
			Sones	BHP	Sones	BHP	Sones	BHP	Sones	BHP	Sones	BHP	Sones	BHP	Sones	BHP	Sones	BHP	Sones	BHP	Sones	BHP	Sones	BHP				
1/3	225	1804	3480		2165		-		-		-		-		-		-		-		-		-					
			2.9	0.06	2.0	0.07	-		-		-		-		-		-		-		-		-		-			
	300	2405	4640		3849		2423		-		-		-		-		-		-		-		-		-			
1/2	372	2983	5753		5164		4386		3184		-		-		-		-		-		-		-		-			
			8.7	0.27	8.0	0.30	7.4	0.33	6.6	0.32	-		-		-		-		-		-		-		-			
	405	3247	6264		5732		5073		4186		-		-		-		-		-		-		-		-		-	
3/4	460	3688	7114		6653		6114		5468		4618		-		-		-		-		-		-		-			
			11.7	0.51	10.8	0.55	10.0	0.59	9.3	0.63	8.5	0.63	-		-		-		-		-		-		-			
	480	3848	7424		6985		6478		5897		5147		4103		-		-		-		-		-		-		-	
1	520	4169	8042		7642		7195		6674		6071		5324		4225		-		-		-		-		-			
			14.1	0.73	13.3	0.79	12.4	0.83	11.6	0.87	10.8	0.91	9.9	0.92	8.9	0.87	-		-		-		-		-			
	534	4281	8259		7871		7443		6939		6375		5691		4760		-		-		-		-		-		-	
1 1/2	560	4490	8661		8295		7890		7427		6927		6303		5559		-		-		-		-		-			
			15.4	0.91	14.8	0.98	14.2	1.02	13.4	1.06	12.7	1.12	11.8	1.14	10.7	1.14	-		-		-		-		-			
	580	4650	8971		8617		8229		7792		7315		6757		6115		-		-		-		-		-		-	
	600	4811	9280		8938		8566		8153		7698		7192		6590		4847		-		-		-		-		-	
2	640	5131	9899		9578		9234		8868		8452		8015		7504		6230		-		-		-		-		-	
			18.4	1.36	17.9	1.44	17.3	1.49	16.8	1.54	16.1	1.59	15.3	1.66	14.5	1.69	12.3	1.69	-		-		-		-		-	
	660	5292	10208		9897		9567		9222		8820		8400		7937		6798		4544		-		-		-		-	
2	677	5428	10471		10168		9848		9513		9129		8724		8302		7235		5744		-		-		-		-	
			19.5	1.61	19.0	1.69	18.6	1.75	18.2	1.80	17.7	1.86	16.9	1.92	16.1	1.99	14.2	2.03	12.5	1.96	-		-		-		-	

# DX30B | BELT DRIVE

HP	RPM	Tip Speed FPM	0.000" SP		0.125" SP		0.250" SP		0.375" SP		0.500" SP		0.625" SP		0.750" SP		1.000" SP		1.250" SP		1.500" SP			
			CFM		CFM		CFM		CFM		CFM		CFM		CFM		CFM		CFM		CFM		CFM	
			Sones	BHP	Sones	BHP	Sones	BHP	Sones	BHP	Sones	BHP	Sones	BHP	Sones	BHP	Sones	BHP	Sones	BHP	Sones	BHP	Sones	BHP
3	710	5693	10981		10692		10392		10073		9723		9346		8952		8011		6801		-			
			20.0	1.86	19.9	1.94	19.5	2.01	19.1	2.06	18.7	2.12	18.1	2.18	17.3	2.26	15.6	2.32	14.0	2.30	-			
	735	5893	11368		11089		10802		10494		10169		9808		9431		8577		7519		5947			
			21.0	2.06	21.0	2.15	20.0	2.22	20.0	2.28	19.6	2.33	19.1	2.39	18.3	2.47	16.8	2.56	15.0	2.59	13.8	2.45		
	760	6093	11755		11485		11210		10912		10611		10263		9905		9120		8163		6886			
22.0			2.28	22.0	2.37	21.0	2.45	21.0	2.51	21.0	2.56	20.0	2.63	19.4	2.70	17.9	2.83	16.3	2.87	14.8	2.79			
777	6230	12018		11754		11488		11196		10905		10569		10224		9485		8564		7426				
		23.0	2.44	22.0	2.53	22.0	2.61	22.0	2.67	21.0	2.73	21.0	2.79	20.0	2.86	18.7	3.01	17.1	3.06	15.5	3.01			
5	815	6534	12605		12354		12102		11827		11549		11249		10924		10244		9441		8513			
			24.0	2.81	24.0	2.91	23.0	3.00	23.0	3.06	23.0	3.12	23.0	3.19	22.0	3.25	21.0	3.42	18.8	3.50	17.2	3.55		
	845	6775	13069		12827		12584		12323		12055		11781		11467		10819		10095		9237			
			25.0	3.14	25.0	3.23	25.0	3.33	25.0	3.40	25.0	3.46	24.0	3.53	24.0	3.60	23.0	3.76	21.0	3.89	18.5	3.94		
	875	7015	13533		13299		13065		12817		12558		12299		12006		11389		10739		9937			
26.0			3.48	26.0	3.58	26.0	3.68	26.0	3.76	26.0	3.83	26.0	3.89	26.0	3.96	24.0	4.12	23.0	4.30	20.0	4.34			
905	7256	13997		13771		13544		13308		13058		12808		12540		11952		11333		10610				
		28.0	3.85	28.0	3.96	28.0	4.06	27.0	4.15	27.0	4.22	27.0	4.28	27.0	4.35	26.0	4.50	24.0	4.70	22.0	4.79			
923	7400	14276		14054		13831		13603		13357		13112		12859		12284		11680		11001				
		29.0	4.09	29.0	4.19	29.0	4.30	28.0	4.39	28.0	4.46	28.0	4.53	28.0	4.60	27.0	4.75	25.0	4.95	23.0	5.07			

Performance certified is for installation type A: Free Inlet, Free Outlet. Power rating (BHP) does not include transmission losses. For further information on estimating belt drive losses and motor service factors see page 13. The sound ratings shown are for loudness values in fan sones at 5'0" (1.5m) in a hemispherical free field calculated per AMCA International Standard 301. Values shown are for installation Type A: free inlet hemispherical sone levels. Performance ratings do not include the effects of appurtenances.

# DX36B | BELT DRIVE

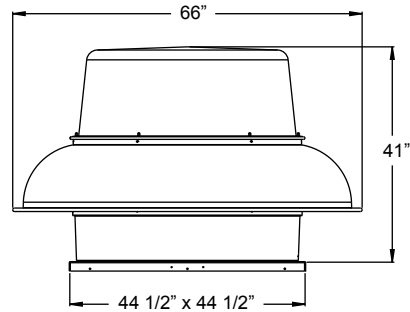
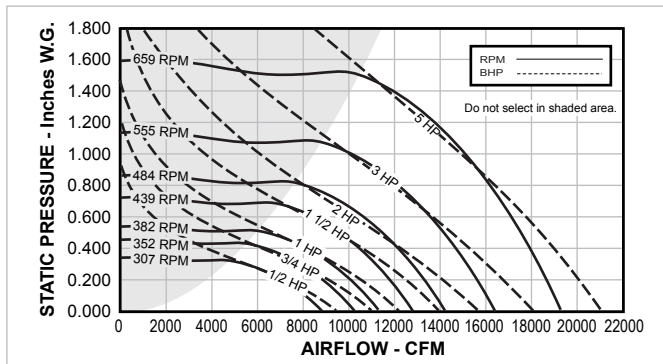

HP	RPM	Tip Speed FPM	0.000" SP		0.125" SP		0.250" SP		0.375" SP		0.500" SP		0.625" SP		0.750" SP		1.000" SP		1.250" SP		1.500" SP			
			CFM		CFM		CFM		CFM		CFM		CFM		CFM		CFM		CFM		CFM		CFM	
			Sones	BHP	Sones	BHP	Sones	BHP	Sones	BHP	Sones	BHP	Sones	BHP	Sones	BHP	Sones	BHP	Sones	BHP	Sones	BHP	Sones	BHP
1/25	215	2093	6343		4855		-		-		-		-		-		-		-		-		-	
			3.9	0.13	3.7	0.18	-		-		-		-		-		-		-		-		-	
	261	2541	7700		6555		4707		-		-		-		-		-		-		-		-	
5.9			0.24	5.6	0.30	5.6	0.31	-		-		-		-		-		-		-		-		
3/4	307	2989	9057		8105		6994		-		-		-		-		-		-		-		-	
			8.0	0.39	7.7	0.46	7.6	0.51	-		-		-		-		-		-		-		-	
	340	3164	9588		8714		7701		6101		-		-		-		-		-		-		-	
9.0			0.46	8.6	0.53	8.3	0.60	7.9	0.61	-		-		-		-		-		-		-		
352		3427	10031		9216		8248		6922		-		-		-		-		-		-		-	
	9.9		0.53	9.4	0.59	8.9	0.68	8.5	0.71	-		-		-		-		-		-		-		
1	365	3553	10385		9613		8675		7497		-		-		-		-		-		-		-	
			10.6	0.58	10.2	0.65	9.5	0.74	9.1	0.79	-		-		-		-		-		-		-	
	375	3651	10768		10037		9130		8086		6338		-		-		-		-		-		-	
11.4			0.65	11.1	0.72	10.2	0.82	9.7	0.87	9.3	0.85	-		-		-		-		-		-		
382		3719	11063		10362		9469		8523		7027		-		-		-		-		-		-	
	12.0		0.71	11.6	0.78	10.8	0.88	10.1	0.94	9.6	0.93	-		-		-		-		-		-		
1 1/2	400	3894	11270		10589		9705		8809		7438		-		-		-		-		-		-	
			12.4	0.75	12.1	0.82	11.3	0.92	10.6	0.99	9.9	1.00	-		-		-		-		-		-	
	415	4040	11801		11169		10314		9503		8351		-		-		-		-		-		-	
			13.5	0.86	13.3	0.93	12.5	1.04	11.7	1.11	10.9	1.16	-		-		-		-		-		-	
		430	4186	12243		11643		10821		10050		9052		7592		-		-		-		-		-
14.6	0.96			14.4	1.04	13.6	1.14	12.8	1.23	12.0	1.29	11.2	1.26	-		-		-		-		-		
2	455	4430	12686		12115		11324		10586		9711		8478		-		-		-		-		-	
			15.5	1.06	15.4	1.15	14.8	1.26	14.0	1.35	13.2	1.42	12.3	1.42	-		-		-		-		-	
	470	4576	12951		12397		11627		10904		10089		8939		-		-		-		-		-	
16.1			1.13	16.1	1.23	15.4	1.33	14.7	1.43	14.0	1.50	13.1	1.53	-		-		-		-		-		
3	505	4916	13423		12896		12168		11453		10719		9706		8341		-		-		-		-	
			17.0	1.26	17.0	1.36	16.5	1.46	15.7	1.57	15.0	1.65	14.3	1.71	13.2	1.66	-		-		-		-	
	525	5111	13866		13364		12671		11959		11271		10386		9229		-		-		-		-	
			17.9	1.39	17.9	1.50	17.5	1.58	16.8	1.71	16.0	1.80	15.4	1.87	14.5	1.86	-		-		-		-	
		540	5257	14279		13798		13139		12432		11778		10998		9945		-		-		-		-
18.8	1.52			18.8	1.63	18.6	1.71	18.0	1.85	17.2	1.95	16.5	2.02	15.8	2.06	-		-		-		-		
555	5403	14899		14449		13830		13143		12523		11839		10942		-		-		-		-		
		21.0	1.72	21.0	1.85	21.0	1.92	20.0	2.07	19.4	2.18	18.6	2.26	17.9	2.34	-		-		-		-		
	555	5403	15489		15061		14481		13814		13212		12584		11822		9607		-		-		-	
22.0			1.94	22.0	2.07	22.0	2.14	21.0	2.29	20.0	2.42	19.6	2.51	19.0	2.58	17.1	2.55	-		-		-		
555	5403	15931		15515		14968		14319		13718		13128		12449		10507		-		-		-		
		22.0	2.11	22.0	2.24	22.0	2.32	22.0	2.46	21.0	2.60	20.0	2.71	19.6	2.78	18.0	2.81	-		-		-		
555	5403	16374		15969		15452		14826		14223		13662		13039		11292		-		-		-		
		23.0	2.29	23.0	2.43	23.0	2.50	22.0	2.65	22.0	2.80	21.0	2.91	20.0	3.00	18.9	3.09	-		-		-		

# DX36B | BELT DRIVE

HP	RPM	Tip Speed FPM	0.000" SP		0.125" SP		0.250" SP		0.375" SP		0.500" SP		0.625" SP		0.750" SP		1.000" SP		1.250" SP		1.500" SP			
			CFM		CFM		CFM		CFM		CFM		CFM		CFM		CFM		CFM		CFM		CFM	
			Sones	BHP	Sones	BHP	Sones	BHP	Sones	BHP	Sones	BHP	Sones	BHP	Sones	BHP	Sones	BHP	Sones	BHP	Sones	BHP	Sones	BHP
5	575	5598	16964		16573		16091		15498		14902		14364		13781		12252		9844		-			
			24.0	2.55	24.0	2.69	24.0	2.77	23.0	2.90	23.0	3.07	22.0	3.20	21.0	3.30	20.0	3.45	18.5	3.30	-			
	595	5793	17554		17177		16721		16166		15575		15043		14505		13160		11240		-			
			25.0	2.82	25.0	2.97	25.0	3.06	25.0	3.17	24.0	3.36	24.0	3.36	24.0	3.62	22.0	3.79	19.8	3.74	-			
	615	5987	18144		17779		17349		16824		16245		15715		15214		14033		12346		-			
			27.0	3.12	27.0	3.27	27.0	3.37	26.0	3.48	26.0	3.66	25.0	3.82	25.0	3.95	23.0	4.13	22.0	4.19	-			
	630	6133	18586		18230		17818		17314		16753		16225		15740		14630		13087		10793			
			28.0	3.35	28.0	3.51	28.0	3.62	28.0	3.72	27.0	3.90	27.0	4.07	26.0	4.21	24.0	4.41	23.0	4.53	21.0	4.34		
	645	6279	19029		18681		18286		17801		17260		16733		16249		15218		13799		11892			
			29.0	3.59	29.0	3.75	29.0	3.87	28.0	3.97	28.0	4.14	27.0	4.32	27.0	4.48	25.0	4.69	24.0	4.87	22.0	4.74		
	659	6416	19442		19101		18722		18255		17730		17205		16722		15732		14438		12737			
			29.0	3.83	29.0	4.00	29.0	4.13	29.0	4.22	28.0	4.38	28.0	4.57	27.0	4.74	26.0	4.97	24.0	5.17	23.0	5.10		

Performance certified is for installation type A: Free Inlet, Free Outlet. Power rating (BHP) does not include transmission losses. For further information on estimating belt drive losses and motor service factors see page 13. The sound ratings shown are for loudness values in fan sones at 5'0" (1.5m) in a hemispherical free field calculated per AMCA International Standard 301. Values shown are for installation Type A: free inlet hemispherical sone levels. Performance ratings do not include the effects of appurtenances.

# KB420 | BELT DRIVE

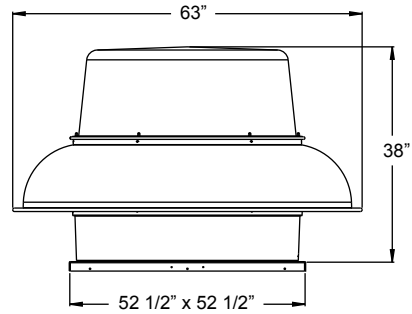
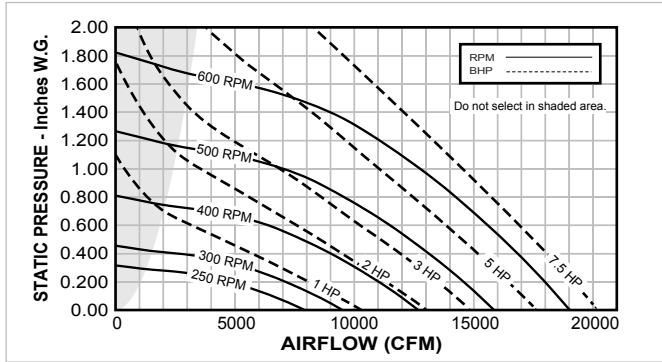

HP	RPM	Tip Speed FPM	0.000" SP		0.125" SP		0.250" SP		0.375" SP		0.500" SP		0.625" SP		0.750" SP		1.000" SP		1.250" SP		1.500" SP												
			CFM		CFM		CFM		CFM		CFM		CFM		CFM		CFM		CFM		CFM												
			Sones	BHP	Sones	BHP	Sones	BHP	Sones	BHP	Sones	BHP	Sones	BHP	Sones	BHP	Sones	BHP	Sones	BHP	Sones	BHP	Sones	BHP									
3/4	240	2765	7680		5591		2284																										
			6.4	0.437	6.3	0.453	6.0	0.311																									
3/4	260	2995	8320		6422		3948																										
			7.2	0.619	7.1	0.584	6.9	0.496																									
1	283	3260	9055		7326		5274																										
			8.2	0.798	8	0.762	7.8	0.693																									
	295	3398	9439		7783		5891		2916																								
8.6			0.904	8.5	0.866	8.2	0.804	7.8	0.588																								
1	300	3456	9599		7971		6144		3460																								
			8.8	0.951	8.6	0.913	8.3	0.853	8.0	0.665																							
1 1/2	308	3548	9855		8271		6516		4137																								
			9.1	1.029	8.9	0.990	8.6	0.932	8.3	0.781																							
1 1/2	330	3801	10559		9084		7505		5535		1893																						
			9.8	1.266	9.6	1.225	9.2	1.170	8.8	1.056	8.8	0.657																					
2	345	3974	11039		9629		8143		6376		3852																						
			10.2	1.446	10.0	1.404	9.6	1.349	8.9	1.252	8.8	0.996																					
	354	4078	11327		9954		8518		6842		4639																						
			10.4	1.562	10.2	1.519	9.7	1.465	9.0	1.374	8.8	1.170																					
365	4204	11679		10348		8972		7402		5410																							
		10.8	1.712	10.4	1.668	10.0	1.614	9.2	1.532	8.9	1.358																						
2	380	4377	12159		10881		9579		8107		6331		3670																				
			11.4	1.932	11.1	1.886	10.7	1.833	10.0	1.754	9.2	1.608	8.9	1.244																			
3	390	4492	12479		11234		9967		8560		6901		4698																				
			11.9	2.089	11.5	2.042	11.1	1.988	10.5	1.912	9.7	1.780	9.7	1.495																			
	420	4838	13439		12285		11112		9866		8473		6798		4437																		
13.2			2.609	12.9	2.559	12.4	2.502	11.9	2.432	11.2	2.329	10.8	2.148	10.8	1.750																		
3	430	4953	13759		12632		11488		10285		8958		7373		5381																		
			13.7	2.800	13.3	2.749	12.8	2.691	12.3	2.621	11.7	2.525	11.2	2.356	10.8	2.045																	
5	440	5068	14079		12978		11862		10699		9416		7939		6171																		
			14.1	3.000	13.7	2.948	13.3	2.889	12.8	2.820	12.2	2.726	11.5	2.575	11.5	2.325																	
	447	5149	14303		13220		12122		10987		9734		8316		6624																		
			14.4	3.145	14.0	3.092	13.5	3.034	13.0	2.965	12.6	2.872	11.8	2.730	11.8	2.495																	
	460	5299	14719		13667		12602		11517		10317		8987		7441																		
			15.0	3.428	14.6	3.374	14.1	3.314	13.5	3.246	13.1	3.156	12.5	3.026	12.2	2.822																	
480	5529	15359		14351		13332		12298		11183		9981		8585		4568																	
		15.7	3.894	15.3	3.838	14.7	3.776	14.1	3.708	13.8	3.622	13.3	3.511	12.8	3.332	12.8	2.490																
500	5760	15999		15031		14054		13064		12020		10894		9644		6507																	
		16.5	4.402	16.0	4.343	15.4	4.279	14.8	4.209	14.3	4.126	14.0	4.020	13.5	3.868	13.3	3.285																

# KB420 | BELT DRIVE

HP	RPM	Tip Speed FPM	0.000" SP		0.125" SP		0.250" SP		0.375" SP		0.500" SP		0.625" SP		0.750" SP		1.000" SP		1.250" SP		1.500" SP			
			CFM		CFM		CFM		CFM		CFM		CFM		CFM		CFM		CFM		CFM		CFM	
			Sones	BHP	Sones	BHP	Sones	BHP	Sones	BHP	Sones	BHP	Sones	BHP	Sones	BHP	Sones	BHP	Sones	BHP	Sones	BHP	Sones	BHP
7 1/2	520	5990	16639		15708		14770		13821		12844		11788		10660		7896		2696					
			17.3	4.951	16.7	4.890	16.1	4.825	15.3	4.754	14.7	4.673	14.5	4.573	14.2	4.446	13.8	3.968	2.466	-				
	532	6128	17023		16113		15197		14271		13332		12306		11218		8641		4515					
			17.7	5.302	17.1	5.240	16.4	5.173	15.7	5.101	14.9	5.023	14.7	4.923	14.4	4.799	14.1	4.372	14.1	3.229	-			
	555	6393	17759		16887		16009		15125		14229		13272		12261		9955		6937					
			18.5	6.020	17.8	5.955	17.1	5.886	16.2	5.813	15.2	5.732	14.9	5.636	14.8	5.519	14.5	5.156	14.5	4.395	-			
	570	6566	18239		17390		16536		15677		14805		13893		12929		10757		8094		3015			
			18.9	6.522	18.2	6.454	17.4	6.384	16.5	6.310	15.4	6.228	14.9	6.134	14.8	6.025	14.7	5.689	14.7	5.081	3.274			
	585	6739	18719		17892		17061		16223		15376		14508		13574		11528		9059		5253			
			19.6	7.050	18.9	6.981	18.1	6.910	17.1	6.834	16.1	6.751	15.2	6.661	15.2	6.551	15.2	6.242	15.2	5.698	15.2	4.395		
	10	599	6900	19167		18359		17548		16731		15905		15074		14164		12237		9904		6832		
				20.3	7.568	19.6	7.498	18.8	7.425	17.9	7.348	16.9	7.264	15.9	7.177	15.9	7.065	15.9	6.787	15.9	6.282	15.9	5.265	

Performance certified is for installation type A: Free Inlet, Free Outlet. Power rating (BHP) does not include transmission losses. For further information on estimating belt drive losses and motor service factors see page 13. The sound ratings shown are for loudness values in fan sones at 5'0" (1.5m) in a hemispherical free field calculated per AMCA International Standard 301. Values shown are for installation Type A: free inlet hemispherical sone levels. Performance ratings do not include the effects of appurtenances.

# JB48 | BELT DRIVE

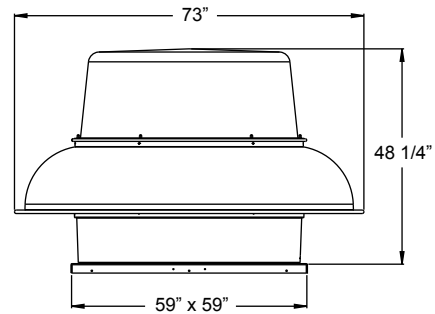
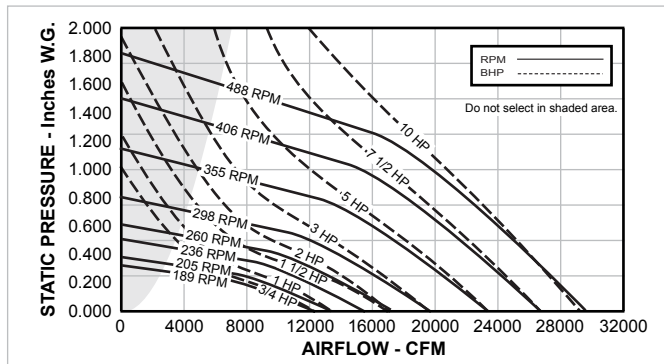

HP	RPM	Tip Speed FPM	0.000" SP		0.125" SP		0.250" SP		0.375" SP		0.500" SP		0.625" SP		0.750" SP		1.000" SP		1.250" SP		1.500" SP			
			CFM		CFM		CFM		CFM		CFM		CFM		CFM		CFM		CFM		CFM		CFM	
			Sones	BHP	Sones	BHP	Sones	BHP	Sones	BHP	Sones	BHP	Sones	BHP	Sones	BHP	Sones	BHP	Sones	BHP	Sones	BHP	Sones	BHP
3/4	160	2105	11842		7937		-		-		-		-		-		-		-		-		-	
			4.6	0.47	4.4	0.42	-		-		-		-		-		-		-		-		-	
	175	2302	12953		9473		-		-		-		-		-		-		-		-		-	
5.4			0.62	5.2	0.57	-		-		-		-		-		-		-		-		-		
1	189	2486	13989		10828		5936		-		-		-		-		-		-		-		-	
			6.0	0.78	5.7	0.73	5.7	0.55	-		-		-		-		-		-		-		-	
	195	2565	14433		11397		7183		-		-		-		-		-		-		-		-	
6.3			0.85	6.0	0.81	5.9	0.66	-		-		-		-		-		-		-		-		
1 1/2	205	2631	14803		11865		8089		-		-		-		-		-		-		-		-	
			6.5	0.92	6.2	0.88	6.0	0.75	-		-		-		-		-		-		-		-	
	205	2697	15173		12308		8799		-		-		-		-		-		-		-		-	
6.8			0.99	6.4	0.95	6.2	0.83	-		-		-		-		-		-		-		-		
2	215	2828	15913		13183		9999		-		-		-		-		-		-		-		-	
			7.2	1.14	6.8	1.10	6.6	0.99	-		-		-		-		-		-		-		-	
	225	2960	16654		14046		11088		5724		-		-		-		-		-		-		-	
7.6			1.31	7.2	1.26	6.9	1.16	6.8	0.80	-		-		-		-		-		-		-		
3	236	3105	17468		14983		12267		8231		-		-		-		-		-		-		-	
			8.1	1.51	7.7	1.47	7.3	1.37	7.1	1.14	-		-		-		-		-		-		-	
	245	3223	18134		15742		13155		9914		-		-		-		-		-		-		-	
8.5			1.69	8.0	1.65	7.7	1.56	7.3	1.38	-		-		-		-		-		-		-		
5	255	3355	18874		16577		14131		11319		5416		-		-		-		-		-		-	
			8.9	1.90	8.4	1.86	8.0	1.78	7.6	1.63	7.6	1.01	-		-		-		-		-		-	
	260	3420	19244		16992		14615		11878		6656		-		-		-		-		-		-	
9.1			2.02	8.6	1.98	8.2	1.89	7.8	1.74	7.7	1.24	-		-		-		-		-		-		
3	270	3552	19984		17817		15572		12978		8983		-		-		-		-		-		-	
			9.5	2.26	9.0	2.22	8.6	2.14	8.1	1.99	7.9	1.66	-		-		-		-		-		-	
	280	3684	20725		18637		16515		14055		11032		4757		-		-		-		-		-	
			9.9	2.52	9.5	2.48	9.0	2.40	8.5	2.26	8.1	2.04	8.1	1.10	-		-		-		-		-	
	290	3815	21465		19457		17414		15124		12455		7271		-		-		-		-		-	
10.5			2.80	10.0	2.77	9.6	2.68	9.2	2.55	8.6	2.36	8.6	1.70	-		-		-		-		-		
298	3920	22057		20091		18116		15911		13468		9191		-		-		-		-		-		
		11.0	3.04	10.4	3.00	9.9	2.92	9.5	2.79	9.0	2.61	8.9	2.13	-		-		-		-		-		
5	315	4144	23315		21458		19589		17568		15336		12614		7315		-		-		-		-	
			11.8	3.59	11.3	3.55	10.8	3.47	10.2	3.36	9.8	3.18	9.5	2.93	9.5	2.06	-		-		-		-	
	330	4341	24425		22655		20871		19007		16935		14702		10848		-		-		-		-	
			12.6	4.13	12.0	4.09	11.4	4.00	10.9	3.90	10.5	3.73	10.1	3.53	10.0	3.00	-		-		-		-	
	345	4539	25536		23842		22138		20420		18461		16365		13809		-		-		-		-	
13.4			4.72	12.7	4.68	12.1	4.59	11.6	4.49	11.1	4.33	10.8	4.13	10.6	3.84	-		-		-		-		
355	4670	26276		24629		22975		21312		19437		17450		15230		6228		-		-		-		
		13.9	5.14	13.3	5.10	12.6	5.01	12.0	4.91	11.4	4.78	11.2	4.57	11.0	4.32	11.0	2.31	-		-		-		

# JB48 | BELT DRIVE

HP	RPM	Tip Speed FPM	0.000" SP		0.125" SP		0.250" SP		0.375" SP		0.500" SP		0.625" SP		0.750" SP		1.000" SP		1.250" SP		1.500" SP			
			CFM		CFM		CFM		CFM		CFM		CFM		CFM		CFM		CFM		CFM		CFM	
			Sones	BHP	Sones	BHP	Sones	BHP	Sones	BHP	Sones	BHP	Sones	BHP	Sones	BHP	Sones	BHP	Sones	BHP	Sones	BHP	Sones	BHP
7 1/2	370	4868	27386		25805		24222		22626		20891		19045		17054		9969		-		-			
			14.7	5.82	14.0	5.77	13.3	5.70	12.7	5.59	12.0	5.46	11.7	5.26	11.6	5.04	11.5	3.71	-	-	-	-		
	385	5065	28496		26976		25458		23923		22322		20569		18696		13361		-		-			
			15.3	6.56	14.7	6.51	14.0	6.44	13.4	6.33	12.7	6.20	12.2	6.01	12.1	5.80	11.9	4.94	-	-	-	-		
	395	5196	29237		27756		26276		24781		23263		21544		19772		15418		6502		-			
			15.8	7.08	15.1	7.03	14.5	6.96	13.8	6.85	13.1	6.73	12.5	6.57	12.4	6.34	12.3	5.70	12.3	3.00	-	-		
	406	5341	30051		28611		27181		25718		24263		22617		20941		17033		9283		-			
			16.3	7.69	15.6	7.64	14.9	7.59	14.3	7.46	13.6	7.34	12.9	7.18	12.8	6.95	12.6	6.39	12.6	4.36	-	-		
10	425	5591	31457		30084		28700		27320		25931		24440		22849		19444		13785		-			
			17.3	8.82	16.5	8.76	15.8	8.71	15.1	8.59	14.4	8.47	13.8	8.32	13.3	8.12	13.2	7.61	13.2	6.37	-	-		
	448	5894	33160		31860		30548		29239		27920		26602		25090		21961		18201		10947			
			18.5	10.33	17.8	10.27	17.2	10.22	16.7	10.10	16.1	9.98	15.6	9.85	15.1	9.67	14.9	9.17	14.9	8.47	14.9	6.18		

Performance certified is for installation type A: Free Inlet, Free Outlet. Power rating (BHP) does not include transmission losses. For further information on estimating belt drive losses and motor service factors see page 13. The sound ratings shown are for loudness values in fan sones at 5'0" (1.5m) in a hemispherical free field calculated per AMCA International Standard 301. Values shown are for installation Type A: free inlet hemispherical sone levels. Performance ratings do not include the effects of appurtenances.



# MB542 | BELT DRIVE

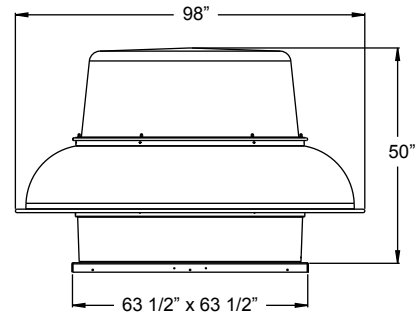
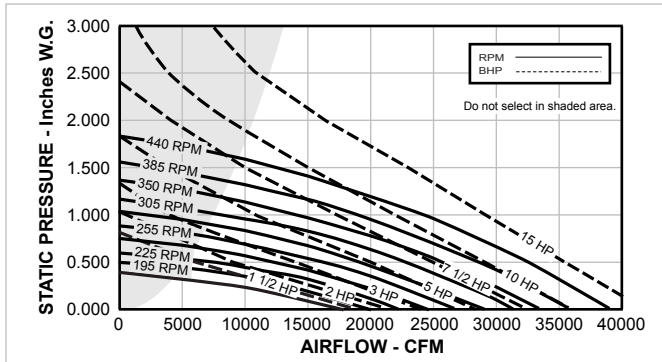

HP	RPM	Tip Speed FPM	0.000" SP		0.125" SP		0.250" SP		0.375" SP		0.500" SP		0.625" SP		0.750" SP		1.000" SP		1.250" SP		1.500" SP			
			CFM		CFM		CFM		CFM		CFM		CFM		CFM		CFM		CFM		CFM		CFM	
			Sones	BHP	Sones	BHP	Sones	BHP	Sones	BHP	Sones	BHP	Sones	BHP	Sones	BHP	Sones	BHP	Sones	BHP	Sones	BHP	Sones	BHP
1 1/2	165	2505	14688		9955		-		-		-		-		-		-		-		-		-	
			5.9	0.70	5.7	0.63	-		-		-		-		-		-		-		-		-	
	175	2657	15578		11226		4004		-		-		-		-		-		-		-		-	
			6.4	0.83	6.1	0.77	5.8	0.52	-		-		-		-		-		-		-		-	
			16468		12456		6493		-		-		-		-		-		-		-		-	
185	2809	6.9	0.99	6.6	0.92	6.3	0.72	-		-		-		-		-		-		-		-		
		17359		13657		8499		-		-		-		-		-		-		-		-		-
2	215	3265	19139		15861		11532		5074		-		-		-		-		-		-		-	
			8.2	1.55	7.9	1.49	7.5	1.32	7.4	0.97	-		-		-		-		-		-		-	
	220	3341	19584		16401		12238		6336		-		-		-		-		-		-		-	
			8.4	1.66	8.1	1.60	7.7	1.44	7.6	1.12	-		-		-		-		-		-		-	
225	3416	20029		16937		12935		7580		-		-		-		-		-		-		-		
		8.7	1.77	8.3	1.72	7.9	1.56	7.8	1.27	-		-		-		-		-		-		-		
3	235	3568	20919		18000		14299		9753		-		-		-		-		-		-		-	
			9.1	2.02	8.8	1.97	8.3	1.82	8.1	1.58	-		-		-		-		-		-		-	
	240	3644	21365		18526		14935		10594		3733		-		-		-		-		-		-	
			9.3	2.15	9.0	2.10	8.5	1.96	8.2	1.72	8.2	1.20	-		-		-		-		-		-	
	245	3720	21810		19050		15565		11373		5028		-		-		-		-		-		-	
9.5			2.29	9.2	2.24	8.7	2.10	8.4	1.86	8.4	1.38	-		-		-		-		-		-		
255	3872	22700		20089		16806		12900		7559		-		-		-		-		-		-		
		9.9	2.58	9.6	2.53	9.2	2.39	8.7	2.16	8.7	1.76	-		-		-		-		-		-		
5	265	4024	23590		21118		18025		14362		9911		-		-		-		-		-		-	
			10.5	2.90	10.1	2.85	9.7	2.72	9.3	2.49	9.2	2.16	-		-		-		-		-		-	
	275	4176	24480		22119		19223		15764		11898		5898		-		-		-		-		-	
			11.0	3.24	10.6	3.19	10.2	3.07	9.8	2.85	9.6	2.57	9.6	1.97	-		-		-		-		-	
	295	4479	26261		24059		21444		18426		14978		10805		4849		-		-		-		-	
11.8			3.99	11.4	3.95	11.1	3.83	10.8	3.64	10.4	3.35	10.4	2.96	10.4	2.26	-		-		-		-		
305	4631	27151		25022		22533		19680		16443		12913		7415		-		-		-		-		
		12.3	4.41	11.8	4.37	11.5	4.25	11.3	4.06	10.9	3.79	10.9	3.48	10.9	2.80	-		-		-		-		
7 1/2	320	4859	28486		26457		24146		21523		18542		15254		11153		-		-		-		-	
			13.0	5.10	12.4	5.05	12.2	4.94	11.9	4.76	11.7	4.51	11.5	4.18	11.5	3.70	-		-		-		-	
	330	5011	29376		27408		25208		22731		19910		16773		13299		-		-		-		-	
			13.4	5.59	12.9	5.54	12.6	5.44	12.4	5.27	12.1	5.03	11.9	4.69	11.9	4.31	-		-		-		-	
	340	5163	30267		28357		26262		23907		21196		18242		15075		5433		-		-		-	
13.9			6.12	13.3	6.06	13.0	5.97	12.8	5.80	12.6	5.56	12.4	5.24	12.4	4.89	12.4	3.44	-		-		-		
350	5315	31157		29301		27307		25020		22452		19652		16627		8009		-		-		-		
		14.3	6.67	13.7	6.62	13.4	6.53	13.2	6.36	13.1	6.13	12.9	5.82	12.8	5.46	12.8	4.15	-		-		-		

# MB542 | BELT DRIVE

HP	RPM	Tip Speed FPM	0.000" SP		0.125" SP		0.250" SP		0.375" SP		0.500" SP		0.625" SP		0.750" SP		1.000" SP		1.250" SP		1.500" SP			
			CFM		CFM		CFM		CFM		CFM		CFM		CFM		CFM		CFM		CFM		CFM	
			Sones	BHP	Sones	BHP	Sones	BHP	Sones	BHP	Sones	BHP	Sones	BHP	Sones	BHP	Sones	BHP	Sones	BHP	Sones	BHP	Sones	BHP
10	365	5542	32492		30713		28862		26668		24304		21723		18899		11779		-		-			
			14.9	7.57	14.2	7.51	13.9	7.43	13.8	7.26	13.7	7.04	13.5	6.77	13.4	6.39	13.4	5.32	-	-	-	-		
	375	5694	33382		31651		29890		27755		25519		23047		20345		14066		-		-			
			15.2	8.21	14.6	8.15	14.2	8.08	14.1	7.90	14.0	7.70	13.9	7.43	13.8	7.06	13.8	6.13	-	-	-	-		
	385	5846	34273		32586		30899		28832		26720		24312		21750		16190		7338		-			
			15.6	8.88	14.9	8.82	14.5	8.76	14.4	8.58	14.3	8.39	14.3	8.11	14.2	7.77	14.1	6.98	14.1	5.23	-	-		
15	410	6226	36498		34914		33330		31490		29537		27407		25146		20095		13644		-			
			16.4	10.72	15.7	10.66	15.2	10.60	15.1	10.44	15.1	10.25	15.1	10.00	15.1	9.70	15.0	8.88	15.0	7.63	-	-		
	420	6377	37388		35842		34296		32540		30634		28620		26413		21604		15884		7586			
			16.8	11.53	16.0	11.46	15.4	11.40	15.4	11.26	15.4	11.06	15.4	10.82	15.4	10.52	15.4	9.72	15.4	8.65	15.4	6.69		
	430	6529	38279		36768		35258		33584		31722		29821		27665		23064		18008		10149			
			17.4	12.37	16.6	12.30	16.0	12.24	15.9	12.11	15.9	11.90	15.9	11.68	15.9	11.38	15.9	10.60	15.9	9.70	15.9	7.77		
	440	6681	39169		37693		36217		34622		32803		30983		28903		24477		19628		12673			
			18.0	13.25	17.3	13.19	16.6	13.12	16.5	13.00	16.5	12.79	16.5	12.58	16.5	12.28	16.5	11.52	16.5	10.63	16.5	8.92		

Performance certified is for installation type A: Free Inlet, Free Outlet. Power rating (BHP) does not include transmission losses. For further information on estimating belt drive losses and motor service factors see page 13. The sound ratings shown are for loudness values in fan sones at 5'0" (1.5m) in a hemispherical free field calculated per AMCA International Standard 301. Values shown are for installation Type A: free inlet hemispherical sone levels. Performance ratings do not include the effects of appurtenances.

# PENNBARRY PRODUCT SOLUTIONS



## Commercial

- Roof & wall exhaust centrifugal fans
- Ceiling, wall, & inline centrifugal fans
- Roof supply centrifugal fans
- Square & round centrifugal fans
- Wall mounted axial fans
- Hooded roof axial fans
- Upblast roof axial fans
- Gravity ventilators
- Roof curbs



## Industrial

- Freestanding centrifugal fans
- Industrial & material handling fans
- Tubular centrifugal inline fans
- Mixed flow centrifugal fans
- Plug & plenum fans
- Wall mounted propeller fans
- Tube axial fans
- Vane axial fans
- Bifurcator fans
- Lab exhaust



## Kitchen ventilation

- Make-up air units
- Exhaust fans



## Energy recovery

- Outdoor units
- Indoor units

PennBarry is proud to be your preferred manufacturer of commercial and industrial fans and blowers. Learn how PennBarry can assist you in your next application by contacting your PennBarry Representative or visiting us on the web at [www.pennbarry.com](http://www.pennbarry.com)

PennBarry | [www.pennbarry.com](http://www.pennbarry.com) | [pennbarrysales@pennbarry.com](mailto:pennbarrysales@pennbarry.com) | Tel 972 212 4700 | Fax 972 212 4702

PennBarry reserves the right to make changes at any time, without notice, to models, construction, specifications, options and availability. This document illustrates the appearance of PennBarry products at the time of publication. View the latest updates on the PennBarry website.

© 2018 PennBarry. All rights reserved. DOMEX OCTOBER 2018.



PENNBARRY™