



Air Monitor

Precision Airflow Measurement
An ONICON Brand

VOLU-probe

PITOT AIRFLOW
TRAVERSE PROBES

The VOLU-probe series uses multiple pitot total and static pressure sensing ports for precise airflow measurement in duct work.



FACTORY CONFIGURED

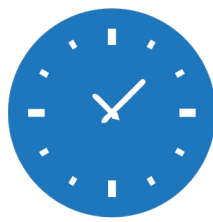

ON TIME DELIVERY



BEST CUSTOMER SERVICE

- Ducted Airflow • Fan Discharge • Fan Tracking •
- Laboratory Hood Exhaust Duct (SS) •

VOLU-probe

PITOT AIRFLOW TRAVERSE PROBES



DESCRIPTION

The VOLU-probe Pitot Airflow Traverse Probe is ideally suited for both new installations and retrofit applications requiring accurate airflow measurement in locations having limited straight duct runs. Multiple sets of total and static pressure sensing ports, positioned along the entire length of the VOLU-probe on an equal area basis, traverse the airstream and average the sensed pressures in separate internal manifolds. An array of VOLU-probes are used to properly sense the typically stratified flow to provide an equal area traverse of an entire duct cross-section. The VOLU-probe is suited for installations in ductwork, fan inlets, sound attenuators, etc., operating at temperatures up to 200°F. As a primary flow sensing means, the VOLU-probe can be used in applications ranging from commercial building HVAC to laboratory, pharmaceutical and electronics production, and health care institutions.

FEATURES

Accuracy - AMCA certified for ±2% of reading accuracy throughout velocity ranges up to 4,000 FPM.

Flow Angle Accommodation - Insensitive to flow angle variations of as much as ±30° when faced in the normal direction of flow.

Minimal Resistance to Airflow - Less than 0.1 inch of water column pressure drop for velocities up to 4,000 FPM.

Environment Versatility - Can operate in any humidity range from 0 to 100% RH without affecting the reading and measures up to 10,000 FPM in heated environments up to 200°F.

Low Velocity Measurement - The amplified signal offering measures down to 120 FPM with ±3% accuracy.

Low Cost - High Accuracy - Achieve ±3% of the reading for a fraction of the cost of thermal dispersion technology.

BMS/BAS Communication - Pairing VOLU-probes with the VELTRON III provides Display, BACnet, MODBUS, and Analog outputs for ±3% of the reading accuracy.

ACCURACY

Air Monitor Corporation certifies that the VOLU-probe Airflow Traverse Probe shown herein is licensed to bear the AMCA Certified Ratings Seal - Airflow Measurement Station Air Performance. The ratings shown are based on tests and procedures performed in accordance with AMCA Publication 611 and comply with the requirements of the AMCA Certified Ratings Program.



Test Data

Model:	VOLU-probe
Type:	Differential Pressure
Conversion Formula:	Velocity = 1096 $\sqrt{\frac{\text{AMS Velocity Pressure}}{\text{Air Density}}}$
Sizes & Shapes Tested:	36" x 36" Rectangular; 36" dia. Circular
Applicable Sizes Rated:	Rectangular stations with cross-sectional areas between 4.5 and 18.0 square feet; Circular ductwork with cross-sectional areas between 3.5 and 14.1 square feet.
Test Setup:	AMCA Stand 610, Figure 1

Test Results - Rectangular Stations

Reference Volume, ACFM	Reference Velocity, AFPM	% Accuracy	Airflow Resistance IN w.c.
35,134	4,015	0.53	.082
31,391	3,488	0.45	.064
26,018	2,891	0.39	.044
19,456	2,162	0.23	.028
13,971	1,552	0.10	.013
8,832	981	-1.40	.005

Test Results - Circular Stations

Reference Volume, ACFM	Reference Velocity, AFPM	% Accuracy	Airflow Resistance IN w.c.
29,602	4,188	1.03	.066
24,915	3,525	0.97	.047
18,728	2,649	0.30	.033
14,463	2,046	0.15	.017
10,455	1,479	0.16	.010
8,285	1,172	-1.37	.005

HOW IT WORKS

The VOLU-probe operates on the Fechheimer Pitot derivative of the multi-point, self-averaging Pitot principle to measure the total and static pressure components of airflow. Total pressure sensing ports, with chamfered entrances to eliminate air direction effects, are located on the leading surface of the VOLU-probe to sense the impact pressure (P_t) of the approaching airstream (see Figure 2). Fechheimer pair of static pressure sensing ports, positioned at designated angles offset from the flow normal vector, minimize the error inducing effect of directionalized airflow. As the flow direction veers from the normal, one static sensor is exposed to a higher pressure ($P_3 +$ part of P_t), whereas the other static sensor experiences a lower pressure ($P_3 -$ part of P_t) of the same magnitude, thereby canceling out the undesired effect of partial total pressure (P_t). It is this unique design of offset static pressure and chamfered total pressure sensors (see Figure 1) that makes the VOLU-probe insensitive to approaching multi-directional, rotating airflow with yaw and pitch up to 30° from straight flow, thereby assuring the accurate measurement of the sensed airflow rate without the presence of an airflow straightener upstream. This unique design of the VOLU-probe is covered by U.S. Patent No. 4,559,835.

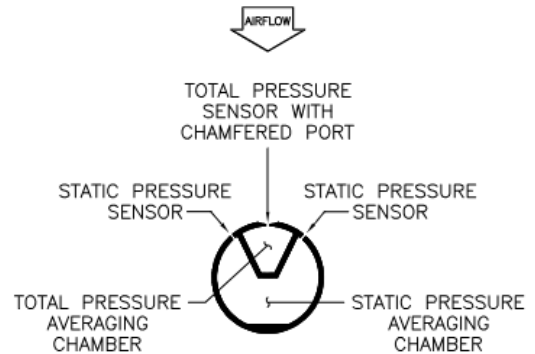

Figure 1

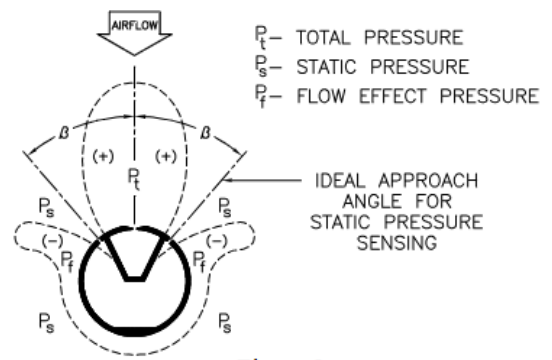
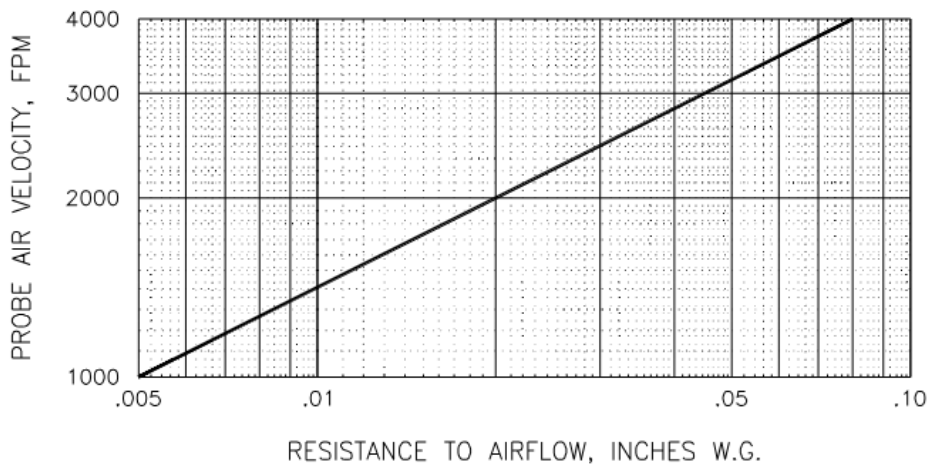

Figure 2

AIRFLOW RESISTANCE

Negligible Resistance to Airflow. The VOLU-probe’s cylindrical configuration and smooth surface, free of external sensor protrusions, permit the airstream to flow unrestricted around and between the installed traverse probe, creating a very minimal if not negligible resistance to airflow.



VOLU-PROBE/1 - EXTERNALLY MOUNTED

The VOLU-probe/1 is designed for mounting in ducts by drilling two holes in opposing walls, without the need to enter those structures. The VOLU-probe/1 is furnished with a threaded end support, gasketed washer and nut, and a mounting plate with signal take-off 1/8" FPT connections.

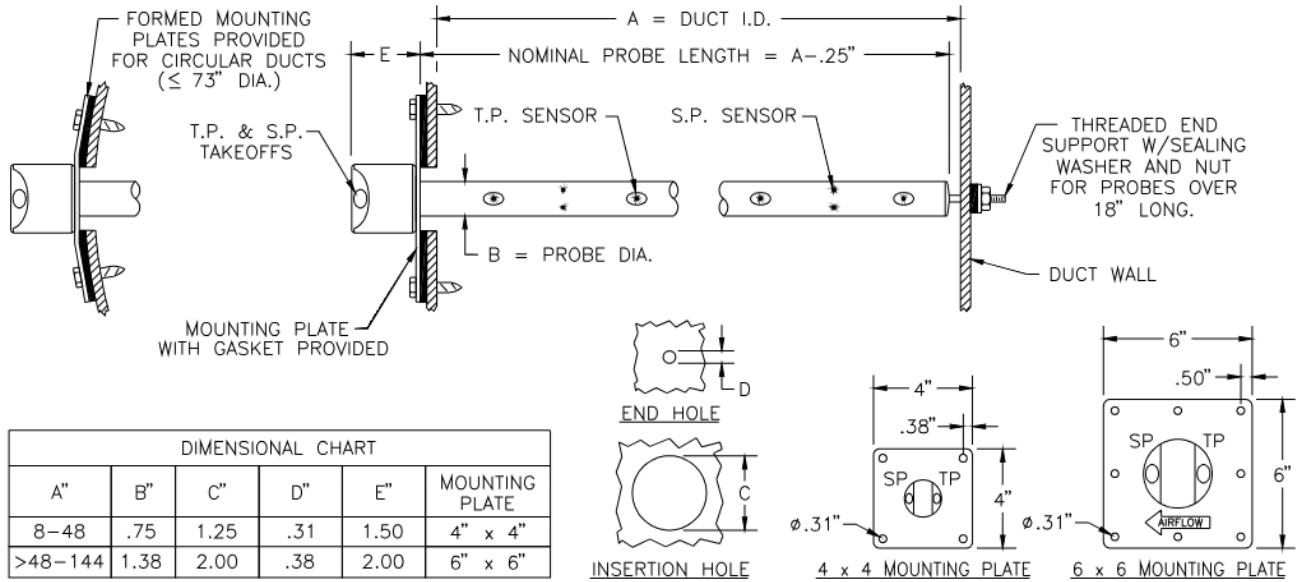

VOLU-PROBE/2 - INTERNALLY MOUNTED

The VOLU-probe/2 is designed for larger ducts where the size permits entry for installation, or where duct external accessibility or clearance is insufficient to permit probe mounting from outside of the duct. The VOLU-probe/2 is furnished with interior mounting end support plates, and midpoint signal take-off 1/8" FPT connections.

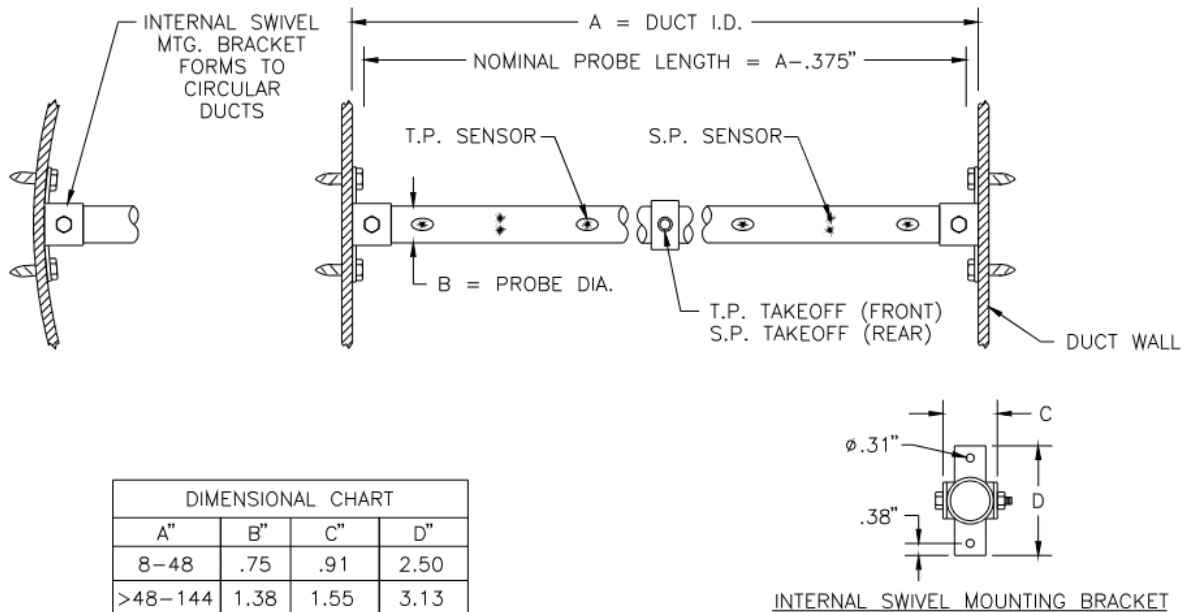

VOLU-PROBE/3 - INSERTABLE/REMOVABLE

The VOLU-probe/3 is designed for mounting in ducts where periodic probe removal may be required for cleaning and/or inspection. The VOLU-probe/3 is furnished with a bell-shaped end support for ease of reinsertion.

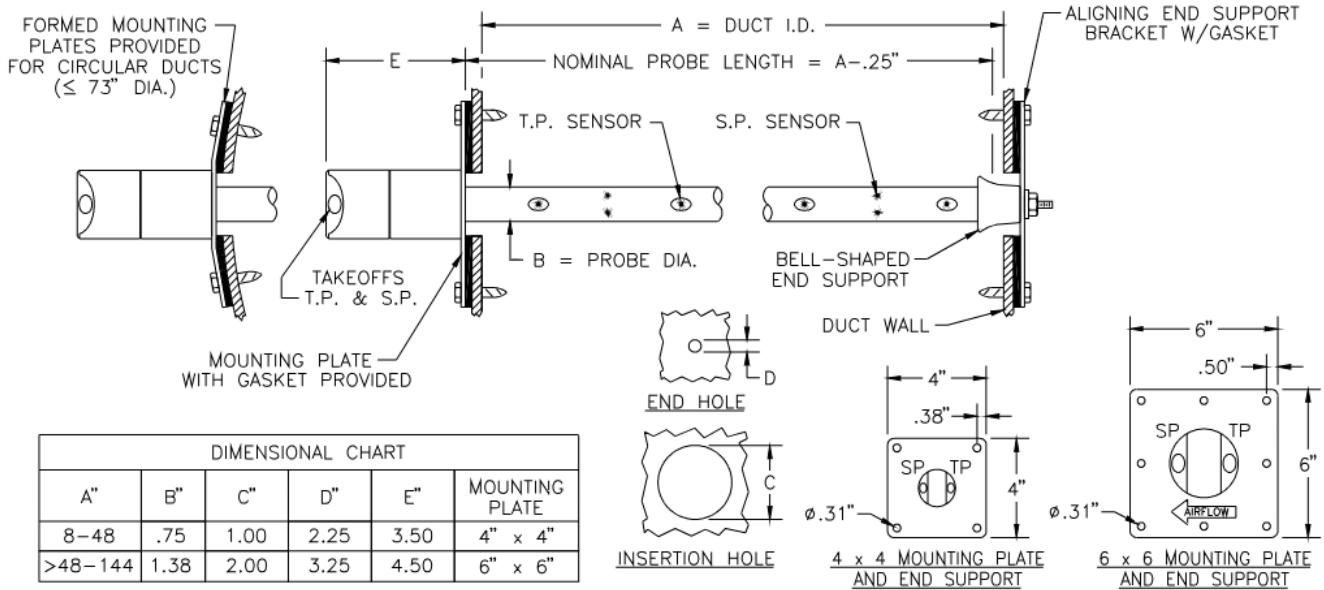

VOLU-PROBE/4 - SELF-SUPPORTED

The VOLU-probe/4 is designed for industrial HVAC and process air applications where the duct casing is of sufficiently heavy gauge or plate construction to support the cantilevered weight of this self-supported VOLU-probe. The VOLU-probe/4 requires no end support and is ideal where periodic removal of the probe may be required for cleaning and/or inspection.

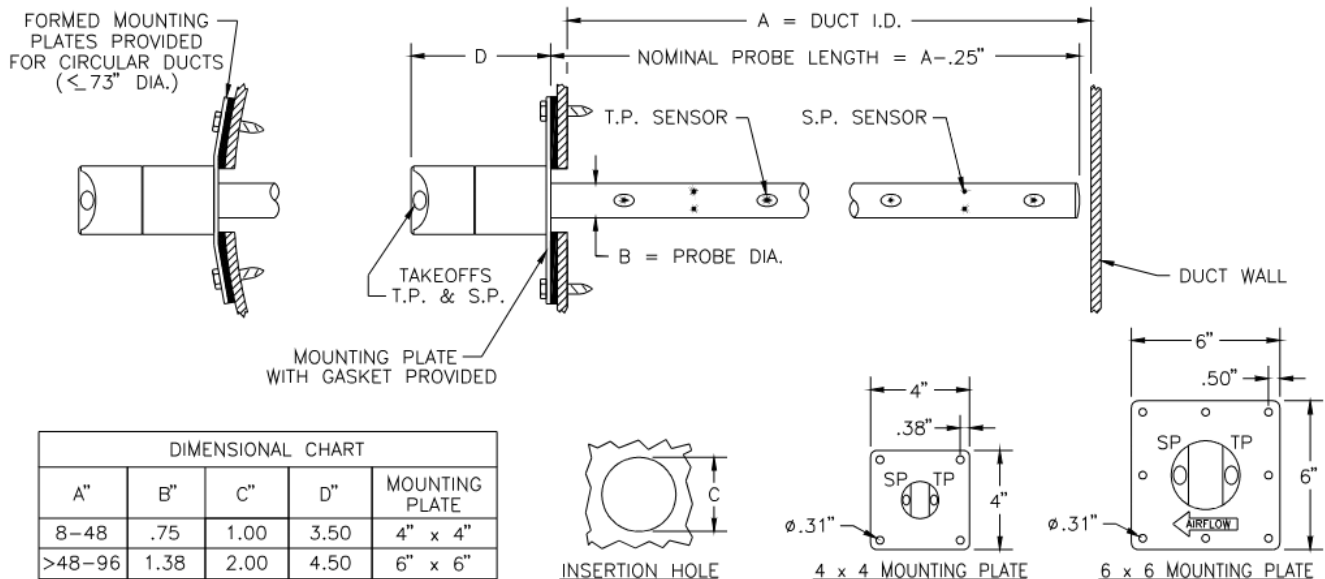

CONSTRUCTION FEATURES

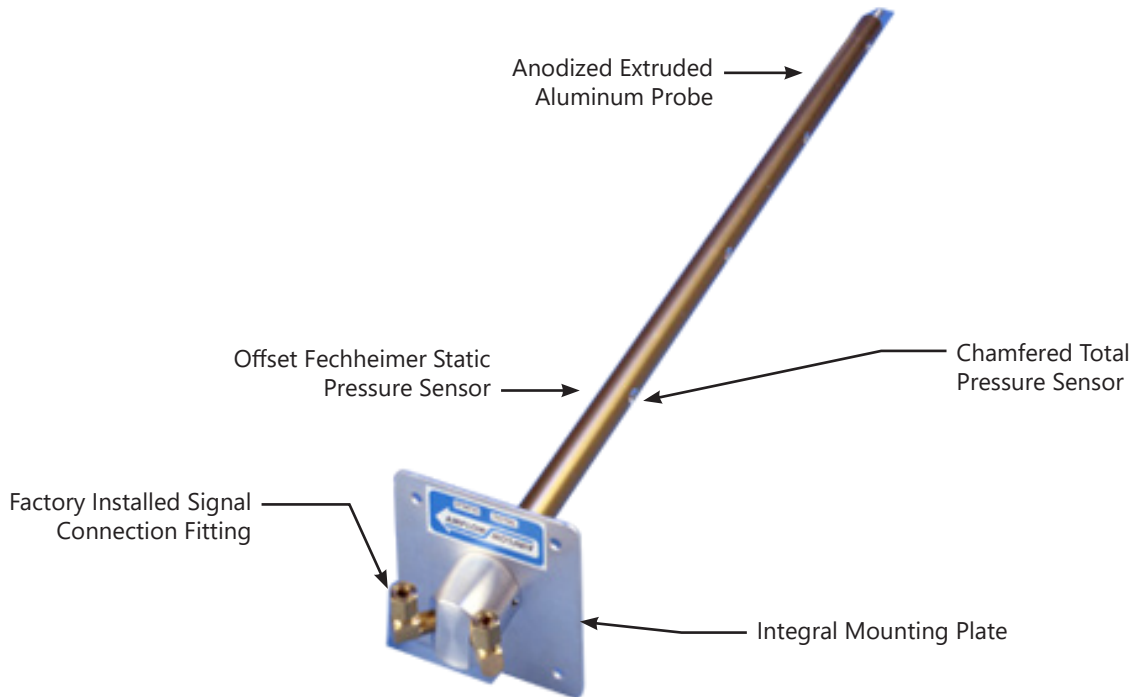

TRAVERSE PROBE QUANTITIES

When installed per Air Monitor’s Minimum Installation Requirements (see Page 7), the quantity and placement of the VOLU-probe airflow traverse probe for a given duct size and configuration (round or rectangular) will produce assured measuring accuracies of $\pm 2\%$ of actual flow.

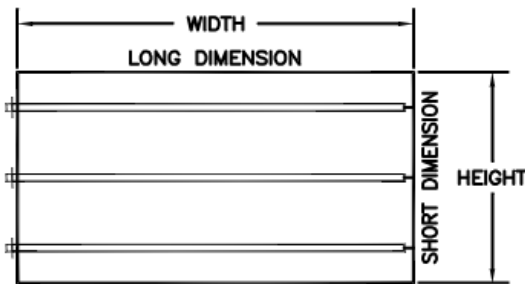

FOR SQUARE AND RECTANGULAR DUCTS

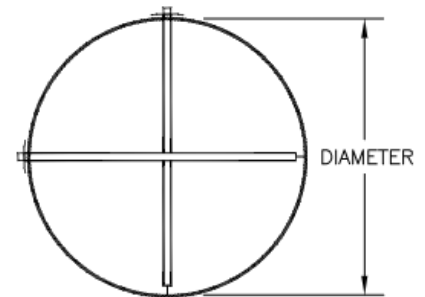

FOR CIRCULAR DUCTS

Height Dimension	Min. Qty of VOLU-probes Recommended	Height Dimension	Min. Qty of VOLU-probes Recommended
8" to 12"	1	> 54" to 84"	4
> 12" to 30"	2	> 84" to 120"	5
> 30" to 54"	3	> 120 to 180"	6

Height Dimension	Min. Qty of VOLU-probes Recommended
8" to 18"	1
> 18" to 72"	2
> 72"	3

MINIMUM INSTALLATION REQUIREMENTS

Note: VOLU-probe locations shown are not ideal. The locations indicate the minimum clearance required from air turbulence producing sources. Wherever possible, the VOLU-probe should be installed where greater runs of straight duct (or clearances) than shown below exist.

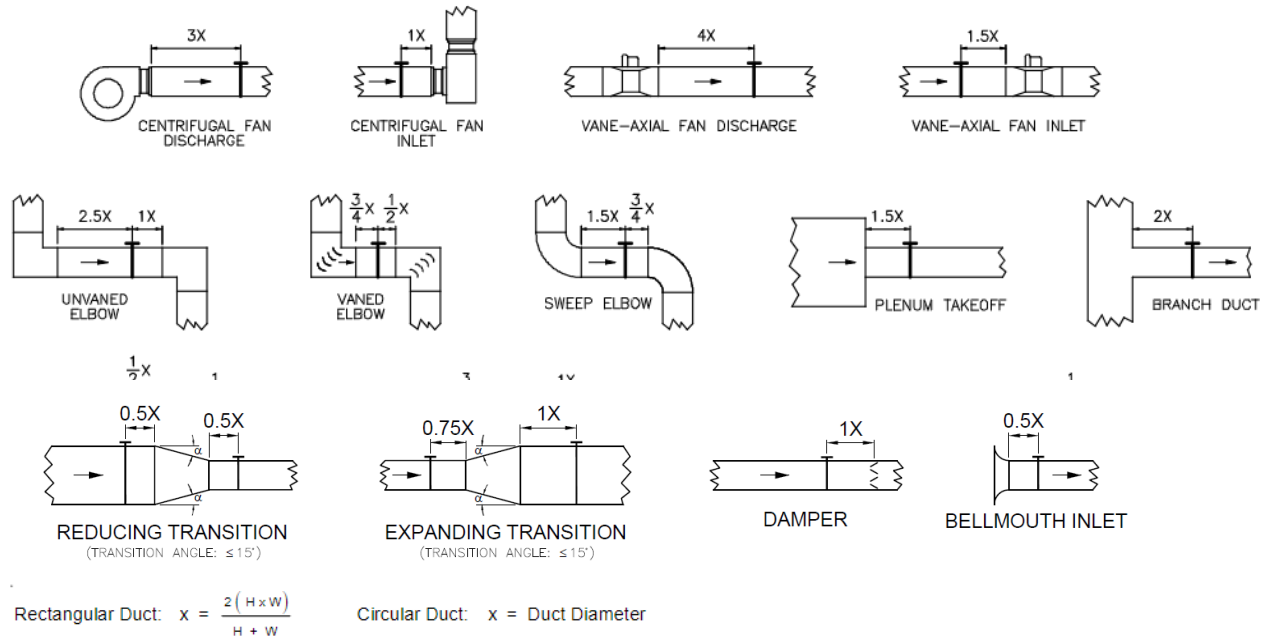

SPECIFICATIONS

VOLU-probe	
ACCURACY	±2%; dependent upon quantity and placement of probes to achieve traverse of ducted airflow.
ACCURACY CERTIFICATION	AMCA Certified to measure the airflow rates within an accuracy of ±2% without the use of correction factors
OUTPUTS	Individually averaged signal of total and static pressure.
OPERATING VELOCITY	400-10,000 FPM. 120 to 600 FPM for VOLU-Probe/AS (Amplified Signal)
OPERATING TEMPERATURE	Continuous operation to 200°F.
HUMIDITY CONDITIONS	0-100% Non-Condensing
DIRECTIONAL SENSITIVITY	Not measurably affected by directional airflows with pitch and yaw angles up to 30°
MEASURED PRESSURE DROP	Pressure drop created by the probes shall not exceed 0.025" w.c. at 2,000 FPM or 0.085" w.c. at 4,000 FPM
RESISTANCE	Less than 0.1 times the velocity pressure head at probe operating velocity
SENSING METHOD	Fechheimer Pitot derivative of the multi-point, self-averaging Pitot principle to measure the total and static pressure components of airflow.
QUANTITY OF PROBES	1 to 6 depending on height dimension of duct
QUANTITY OF SENSING PORTS	Rectangular: 8" to 144", 2 to 16 ports per probe Circular: 8" to 144", 4 to 12 ports per probe
MATERIAL OF CONSTRUCTION	Type 6063 anodized aluminum extrusion. SS option available
OPERATIONAL PRESSURE RANGE - VP/1,2,3,4	0 to 30 in. WC (transmitter limitations)
OPERATIONAL PRESSURE RANGE - VP/AS	0 to 0.1 in. WC
MOUNTING OPTIONS	1 - Externally Mounted 2 - Internally Mounted 3 - Insertable / Removable 4 - Self-Supported

PROBE ORDERING INFORMATION

VOLU-probe Model Number Codification = VOLU-probe-ABBC-DDEFG

VOLU-probe

A = Probe Mounting Configuration

- 1 = Externally mounted
- 2 = Internally mounted (Normalized signal only)
- 3 = Removable (Normalized signal & >18" only)
- 4 = Self supported (Normalized signal & up to 48" only)

BB = Probe Style

- NS = Normalized signal (default)
- AS = Amplified signal
- PP = Purgeable probe (up to 48" only)

C = Materials of Construction Probe

- 1 = 6063 anodized aluminum
- 2 = 316 stainless steel (External or Internal only)

DD = Configuration

- RR = Rectangular
- CC = Circular
- OL = Oval - Long Dimension
- OS = Oval - Short Dimension (req. 2 probes)

E = Probe Length

- | | |
|-----------------|-------------------|
| A = 8" to 12" | I = >60" to 72" |
| B = >12" to 18" | J = >72" to 84" |
| C = >18" to 24" | K = >84" to 96" |
| D = >24" to 30" | L = >96" to 108" |
| E = >30" to 36" | M = >108" to 120" |
| F = >36" to 48" | N = >120" to 132" |
| G = >48" to 54" | O = >132" to 144" |
| H = >54" to 60" | |

F = Number of Probes in Array

- 1 = One
- 2 = Two
- 3 = Three
- 4 = Four
- 5 = Five
- 6 = Six

G = Process Connections

- 1 = 1/4" brass compression ftg (default, AI only)
- 2 = 1/4" brass hose barb ftg (AI only)
- 3 = 1/4" SS compression ftg (SS only)
- 4 = 1/4" FNPT connection (default, SS only)

